

Backflushing Filter AutoFilt® RF4

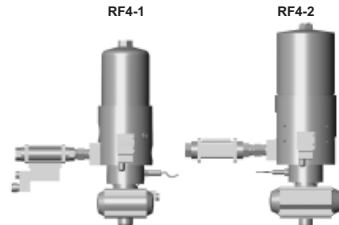

1. TECHNICAL SPECIFICATIONS

1.1 GENERAL

The automatic back-flushing filter AutoFilt® RF4 is a self-cleaning system for removing particles from low-viscosity fluids. Its robust construction and automatic back-flushing capability make a major contribution to operational reliability and **reduce operating and maintenance costs.**

The slotted tube or SuperMesh filter elements with **filtration rates from 25 to 1000 µm** ensure highly effective separation of contaminating particles from the process medium.

Automatic cleaning starts as soon as the elements become contaminated.

The flow of filtrate is not interrupted during the back-flushing procedure.

Two sizes allow **flow rates from 40 l/min to 220 l/min.**

The AutoFilt® RF4 is available as a fully automatic or purely manual version.

Numerous combinations of materials and equipment as well as **individually adjustable control parameters** allow optimum adaptation of the filter to any application.

1.2 OPERATION OF THE AUTOFILT® RF4 Filtration

The fluid to be filtered flows through the slotted-tube filter elements of the back-flushing filter, passing from the inside to the outside.

Contamination particles then collect on the smooth inside of the filter elements.

As the level of the contamination increases, the differential pressure between the contaminated and clean sides of the filter increases. When the differential pressure reaches its pre-set value, back-flushing starts automatically.

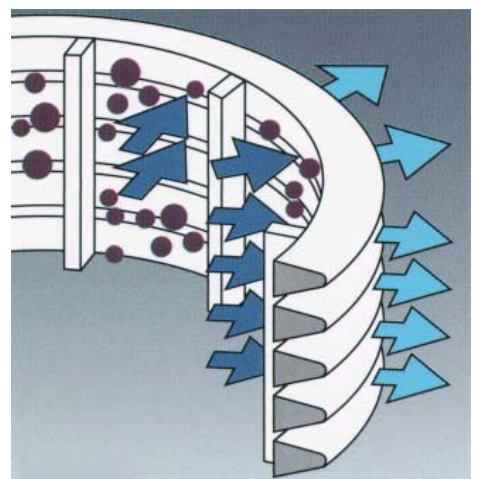
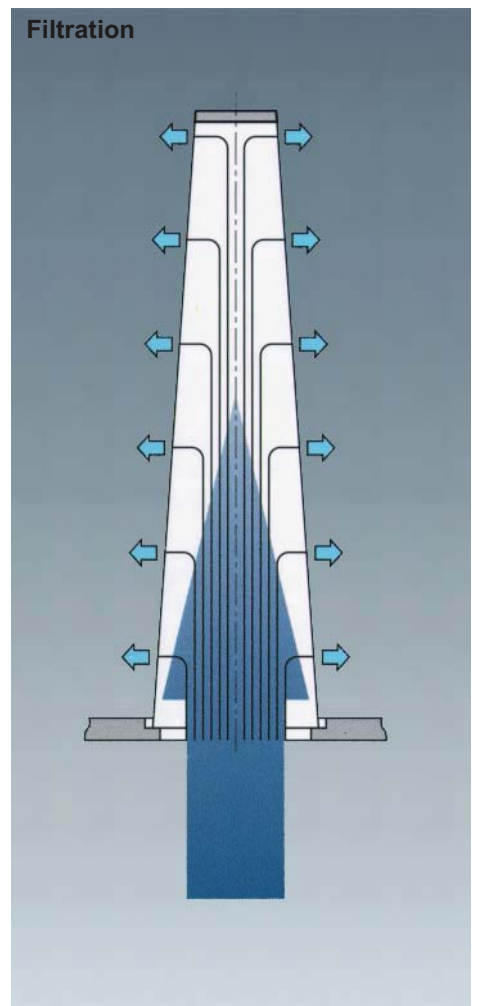

Triggering automatic back-flushing

Back-flushing is triggered automatically when the triggering differential pressure is exceeded.

As soon as back-flushing has been triggered, the filter starts to clean the filter elements.

Triggering back-flushing on manual version

As soon as the visual clogging indicator responds, back-flushing is started manually.

Back-flushing of the filter elements – back-flushing cycle

- The turning drive turns the element plate through an angle of 90°. This brings a clean filter element into filtration, and a contaminated filter element is positioned over the fixed flushing connection.
- The back-flushing valve is opened.
- The pressure drop between filtrate side and back-flushing line flushes a small part of the filtrate backwards into the filter elements to be cleaned. The contamination particles collected on the inside of the filter elements are loosened and flushed into the back-flushing line via the flushing arm.
- As soon as the "back-flushing time per element" has elapsed, the back-flushing valve is closed. In this way all the filter elements are flushed in succession. A back-flushing cycle is terminated when all the filter elements have been cleaned.

On the AutoFilt® RF4 with manual back-flushing, the element plate including filter elements is turned and the back-flushing valve is opened by hand.

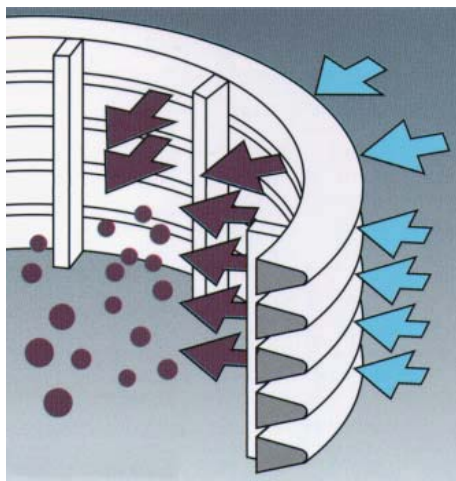
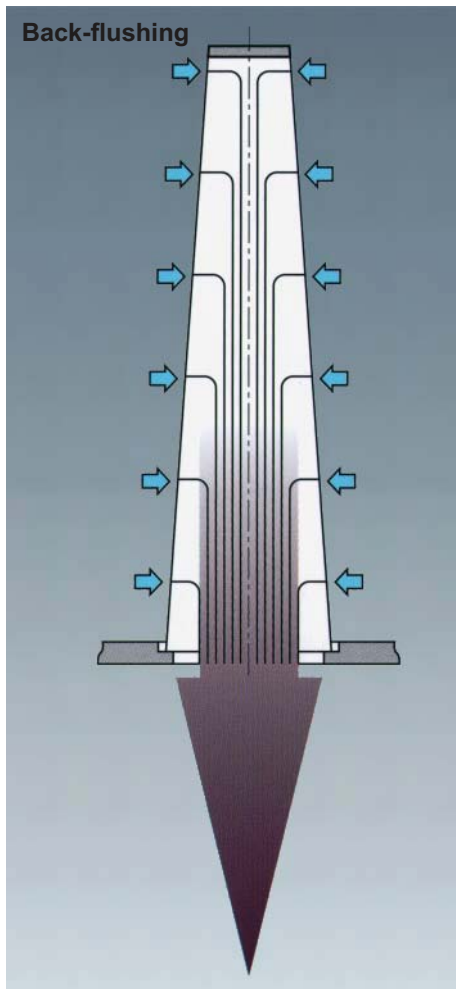

1.3 SPECIAL FEATURES OF THE AUTOFILT® RF3

Isokinetic filtering and back-flushing

The special conical shape and configuration of the filter elements allows even flow, resulting in low pressure drop and complete cleaning of the elements. The advantage: fewer back-flushing cycles and lower loss of back-flushing fluid.

Pulse-aided back-flushing

The filter element to be back-flushed remains in the flushing position for only a few seconds. Rapid opening of the pneumatic back-flushing valve generates a pressure surge in the openings of the filter elements that provides an additional cleaning effect to the back-flushing process.

Low back-flushing quantities due to cyclic control

The back-flushing valve opens and closes during back-flushing of each filter element.

2. FILTER SPECIFICATIONS

2.1 STANDARD CONFIGURATIONS

2.1.1 Control parameters

- EPT: electro-pneumatic cyclic control
- ET: electrical control (electric only)
- M: manual

2.1.2 Connection voltages

- 230 V AC main voltage, 230 V AC or 24 V DC control voltage

Only for ET control versions:

- Control voltage 24 V DC, drive 240 V AC 50 Hz
- Control voltage 24 V DC, drive 115 V AC 60 Hz

2.1.3 Housing materials (combinations)

- Aluminium, anodised
- Stainless steel
- Carbon steel, nickel-plated
- Polyamide (PA)

2.1.4 Material of internal parts

- Stainless steel

2.1.5 Material of elements

- Stainless steel

2.1.6 Back flushing valve

- Coaxial valve
- Lateral valve
- Stainless steel ball valve
- Carbon steel ball valve

2.1.7 Differential pressure monitoring

- Differential pressure switch with or without adjustment option

2.1.8 Filtration ratings

- 25 µm, 40 µm and 60 µm Super-Mesh
- 50 µm to 1000 µm slotted tube

2.1.9 Electrical protection class

- IP54

2.1.10 Pressure ranges

- 6 bar
- 16 bar
- 25 bar

2.2 OPTIONAL VERSIONS

There is a range of optional versions available for the AutoFilt® RF4. For technical details and prices, please contact our Technical Sales Department at our Head Office.

2.2.1 Control / electrical components / voltage supply

- Special voltages
- Customised special solutions

2.2.2 Filter elements

- Superflush element technology
- Elements with magnetic filtration technology

2.2.3 Documentation

- Manufacturer's test certificates
- Material certificates 3.1 according to DIN EN 10204

And many others on request.

Further optional models on request.

2.3 OVERVIEW OF TECHNICAL SPECIFICATIONS OF STANDARD MODELS

Size	Pressure ¹⁾ range [bar]	Connection ²⁾ Inlet / outlet	Connection Back-flush line (PN16)	Weight [kg]	Volume [l]	No. of elements	Filtration area [cm ²]	Back-flush vol. ²⁾ [l]
RF4-1	6	G 1"	G 1/2"	13	2.5	4 x KM	548	4
RF4-1	16	G 1"	G 1/2"	15	2.5	4 x KM	548	4
RF4-2	6	G 1 1/2"	G 3/4"	32	3.7	4 x KN	1420	13
RF4-2	16	G 1 1/2"	G 3/4"	63	3.7	4 x KN	1420	13

Max. permissible temperature for all AutoFilt® RF4: 90°C

- 1) Pressure range: 6 bar for quick-clamp fastening, 16 bar for screw-type model
- 2) based on EPT/ET control mode with opening time of back-flushing valve of 1.5 seconds and 1.5 bar differential pressure between outlet and back-flushing line.

2.4 CIRCUIT DIAGRAM

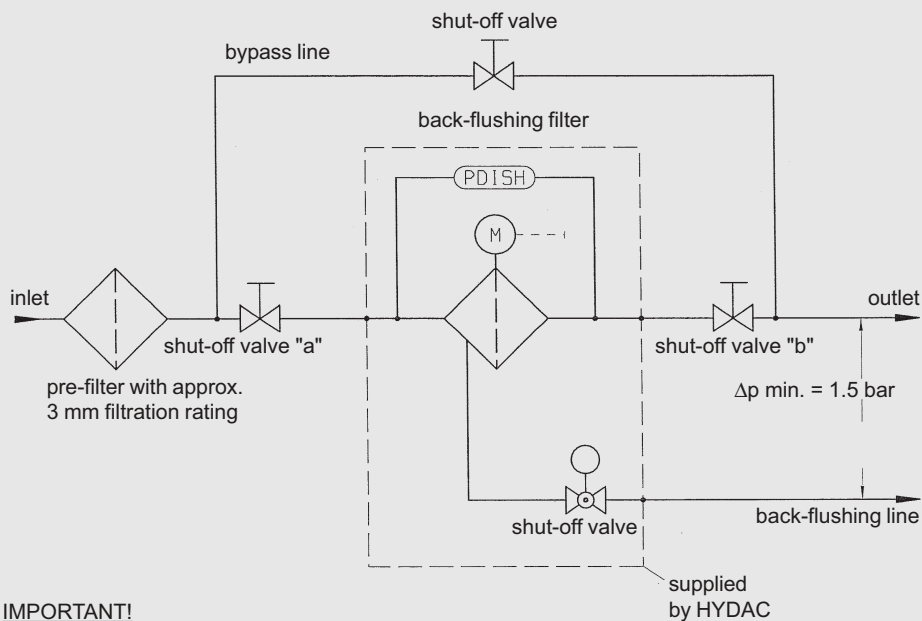

IMPORTANT!
For cleaning there must be a minimum pressure difference between the outlet and back-flushing line of 1.5 bar.

3. MODEL CODE AUTOFILT® RF4

RF4 - 2 - EPT1 - AE - E - CO - 1 - 06 - X / KNS1000 - 1234567

Filter types

RF4-1 = AutoFilt® RF4, size 1
RF4-2 = AutoFilt® RF4, size 2

Type of control

M = manual (only for RF4-1)
EPT = electro-pneumatic cyclic control (including pneumatic drive)
ET = electrical control (only for RF4-1)

Type of voltage

0 = without control, without solenoid valve
1 = with control* and solenoid valve 230 V AC
2 = with control* and solenoid valve 24 V DC
3 = without control, with solenoid valve 230 V AC
4 = without control, with solenoid valve 24 V DC

Only for ET control:

1A = control voltage 24 V DC, drive 240 V AC 50Hz
1B = control voltage 24 V DC, drive 115 V AC 60Hz

Materials

	Lower part of filter	Upper part of filter	Note
AA	Aluminium ALMG3	Aluminium ALMG3	Only RF4-1, 16 bar
AE	Aluminium ALMG3	Stainless steel	Only RF4-2, 6 bar
AP	Aluminium ALMG3	Polyamide PA 66 GF 35	Only RF4-1, 6 bar
EE	Stainless steel	Stainless steel	RF4-1, RF4-2, 6 bar
NN	Carbon steel	Carbon steel	Only RF4-2, 16 bar

Internal parts

E = stainless steel

Back-flushing valve

0 = without back-flushing valve
CO = coaxial valve
LA = lateral valve (only on EPT model)
KN = ball valve, carbon steel (only on manual version)
KE = ball valve, stainless steel (only on manual version)

Differential pressure monitoring

0 = without differential pressure monitoring
1 = fixed value: 0.5 bar, type DS 32
2 = adjustable: 0.1 - 1 bar, type DS 31

Pressure range

06 = 6 bar (housing fastened with clamp)
16 = 16 bar (filter upper section threaded)

Modification number

X = the latest version is always supplied

Elemente / filtration rating

For RF4-1:

KMS = slotted tubes 50 µm - 1000 µm
KDM = SuperMesh 25 µm, 40 µm, 60 µm
SKMS = slotted tube Superflush 50 µm to 1000 µm
SKMD = Supermesh Superflush 25 µm, 40 µm, 60 µm

For RF4-2:

KNS = slotted tubes 50 µm - 1000 µm
KND = SuperMesh 25 µm, 40 µm, 60 µm
SKNS = slotted tube Superflush 50 µm to 1000 µm
SKND = Supermesh Superflush 25 µm, 40 µm, 60 µm

Drawing number

For special models

* Supply voltage of control 230 V AC, 50 Hz

4. FILTER CALCULATION / SIZING

4.1 PRESSURE DROP CURVES

The pressure drop curves apply to water and other fluids up to a viscosity of 15 mm²/s.

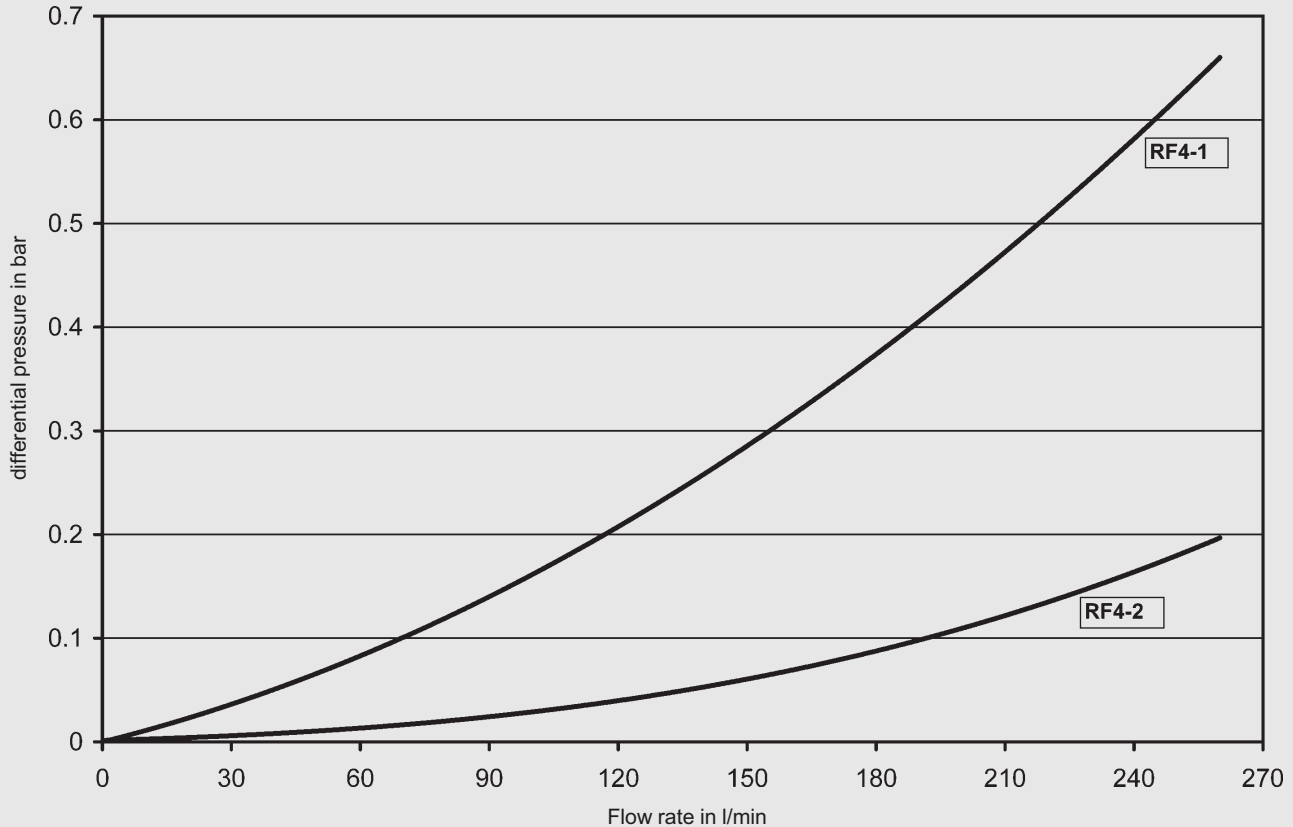

It is crucial when operating the AutoFilt® RF4 that there is a differential pressure between the back-flushing line and filter outlet of at least 1.5 bar. This minimum pressure differential ensures the operation of the filter.

In order to be able to size the filter correctly, the following design data should be available:

- Flow rate
- Type of medium
- Materials / resistance
- Viscosity
- Required filtration rating
- Particulate loading in the fluid
- Type of contamination
- Operating pressure
- Operating temperature - must be below the boiling point of the medium
- Power supply and compressed air supply
- Pressure ratios after the AutoFilt® RF4 (is there any back pressure?)
- Integration of the AutoFilt® RF4 in the whole system

The pressure drop curves and the tables, including one for special emulsion applications, can be used to calculate the AutoFilt® RF4. Generally speaking, an initial Δp (clean condition of the filter) of 0.2 bar should not be exceeded. The pressure drop curve applies to filtration ratings of 100 - 1000 μm slotted tube and 25 μm , 40 μm and 60 μm SuperMesh.

A further factor in the calculation is the flow velocity through the flange inlet. It should not exceed 4 m/s.

When sizing the AutoFilt® RF4, the calculation of water applications and emulsion applications must be treated separately because of the different contamination load (see point 4.2. Calculation tables).

4.2 CALCULATION TABLES

The calculation tables form an important basis for deciding the choice of AutoFilt® RF4.

In particular the higher contamination load in emulsion applications demands more generous sizing of the filter.

The following points must also be taken into account for emulsion applications:

- Table applies to emulsions and oils with a viscosity of up to 15 mm²/s
- For applications in the areas of cast iron machining, grinding and honing and for fluids with a viscosity above 15 mm²/s, Head Office must definitely be consulted.

4.2.1 Water applications

Fluid	Max. flow rate [l/min]	
	RF4-1	RF4-2
Water	120	220

The flow rate ranges indicated apply to filtration ratings $\geq 100 \mu\text{m}$.

4.2.2 Cooling lubricants

Fluid: emulsion

Machined material	Type of machining	Max. flow rate [l/min]	
		RF4-1	RF4-2
Aluminium	Cutting	100	220
Cast iron ¹⁾	Cutting	70	180
Carbon steel	Cutting	80	200
Stainless steel	Cutting	80	200
Aluminium	Grinding	90	200
Cast iron ¹⁾	Grinding	50	140
Carbon steel	Grinding	60	150
Stainless steel	Grinding	60	150

The flow rate ranges indicated apply to filtration ratings $\geq 100 \mu\text{m}$ and a maximum contamination capacity of 200 mg/l.

¹⁾ wire mesh is generally unsuitable for cast iron applications.

5. DIMENSIONS

5.1 DIMENSIONS OF SIZE 1

RF4-1 (6 bar with coaxial valve)

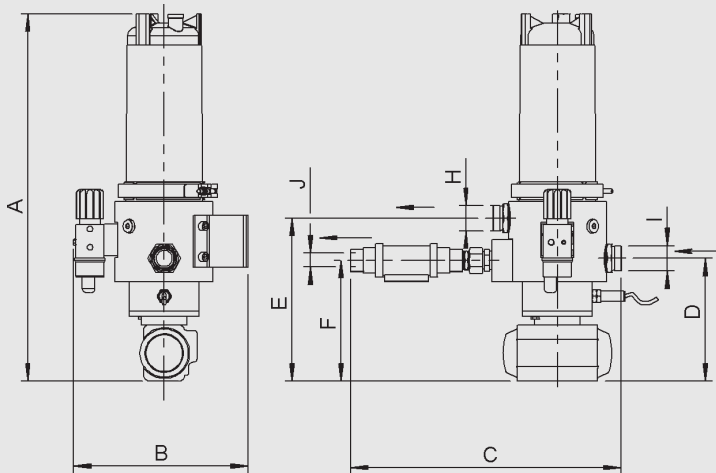

RF4-1 (16 bar with coaxial valve)

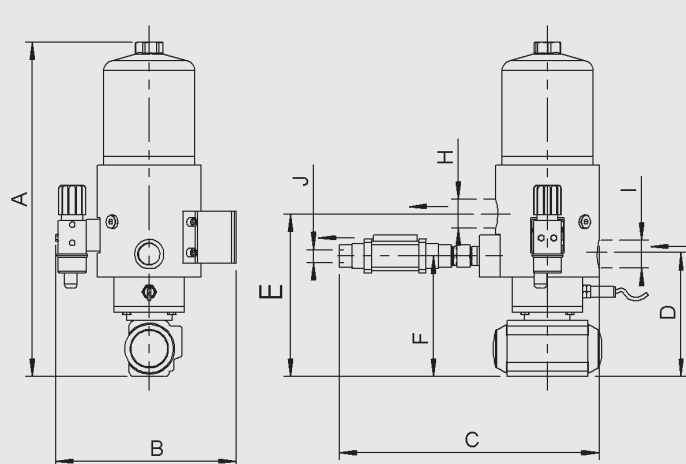

RF4-1 (6 bar with lateral valve)

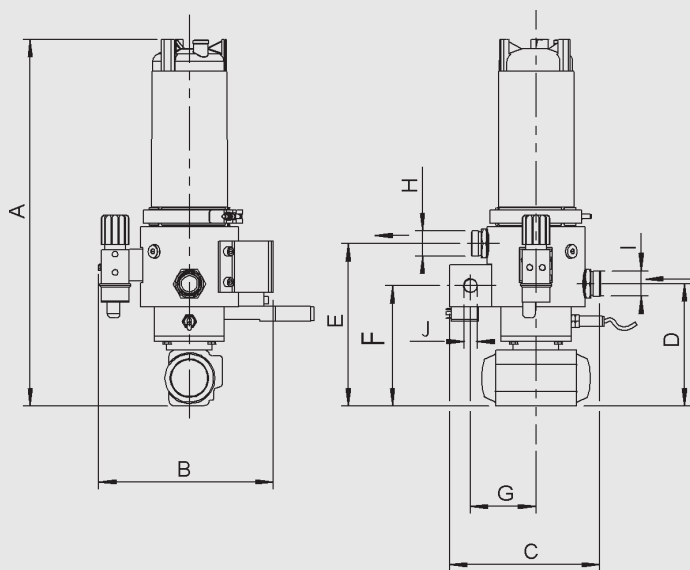

RF4-1 (16 bar with lateral valve)

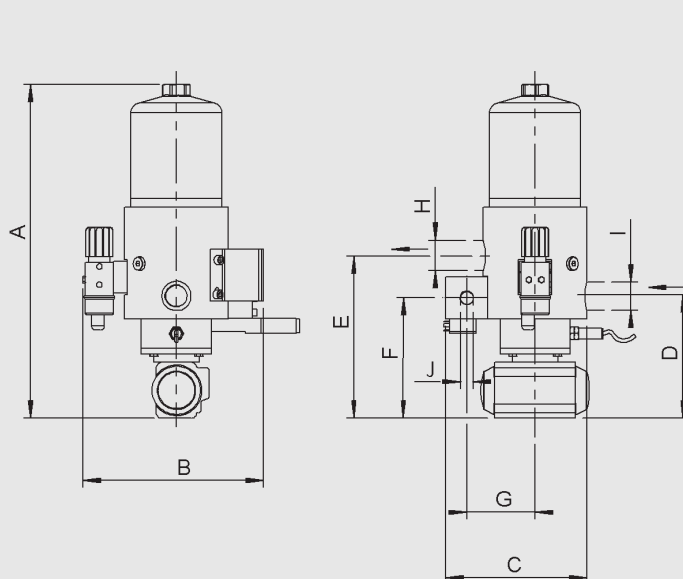

- The filter must not be used as a pipe support
- The dimensions indicated have ± 5 mm tolerances

Type:	A	B	C	D	E	F	G	H	I	J
RF4-1 (6 bar / coaxial valve)	537	250	387	188	245	185	-	1"	1"	1/2"
RF4-1 (6 bar / lateral valve)	537	250	214	188	245	185	94	1"	1"	1/2"
RF4-1 (16 bar / coaxial valve)	490	258	372	188	245	185	-	1"	1"	1/2"
RF4-1 (16 bar / lateral valve)	490	258	250	188	245	185	94	1"	1"	1/2"

5.2 DIMENSIONS OF SIZE 2

RF4-2 (6 bar with coaxial valve)

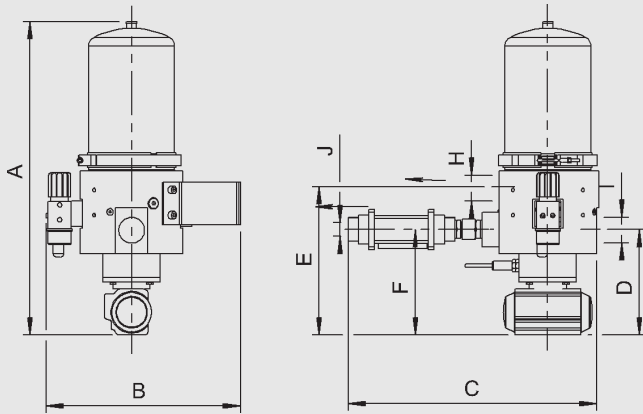

RF4-2 (16 bar with coaxial valve)

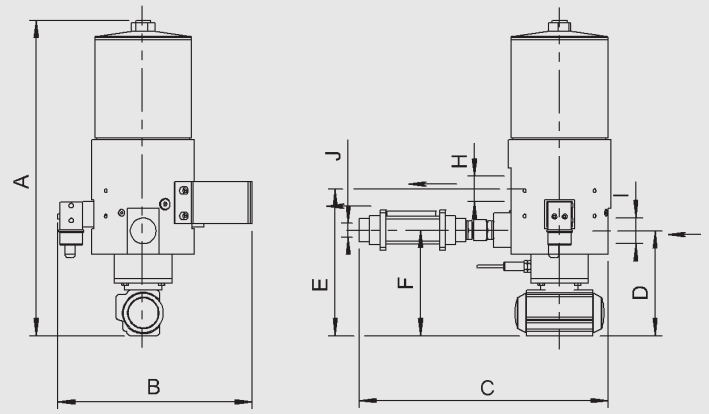

RF4-2 (6 bar with lateral valve)

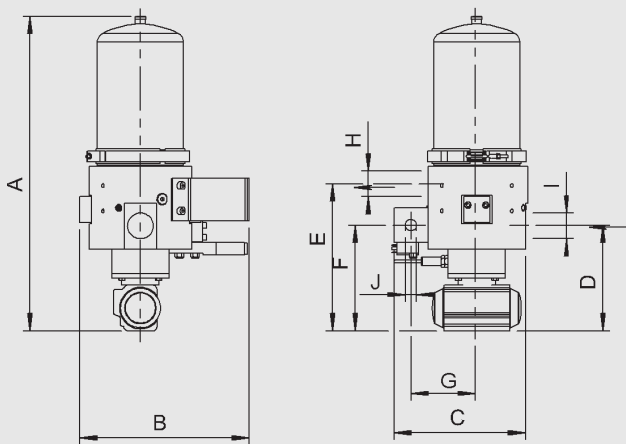

RF4-2 (16 bar with lateral valve)

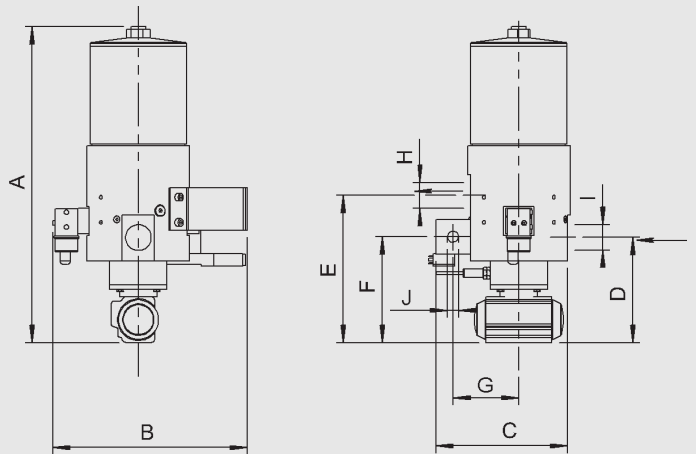

- The filter must not be used as a pipe support
- The dimensions indicated have ± 5 mm tolerances

Type:	A	B	C	D	E	F	G	H	I	J
RF4-2 (6 bar coaxial valve)	559	339	433	196	269	197	–	1 1/2"	1 1/2"	3/4"
RF4-2 (6 bar lateral valve)	559	339	230	196	269	197	114	1 1/2"	1 1/2"	1/2"
RF4-2 (16 bar coaxial valve)	559	296	433	196	269	197	–	1 1/2"	1 1/2"	3/4"
RF4-2 (16 bar lateral valve)	559	339	230	196	269	197	114	1 1/2"	1 1/2"	1/2"

NOTE

The information in this brochure relates to the operating conditions and applications described. For applications or operating conditions not described, please contact the relevant technical department.

Subject to technical modifications.

HYDAC Process Technology GmbH
 Am Wrangelflöz 1
 D-66538 Neunkirchen
 Tel.: 0 68 21 / 86 90 - 0
 Fax: 0 68 21 / 86 90 - 200
 Internet: www.hydac.com
 E-Mail: prozess-technik@hydac.com