

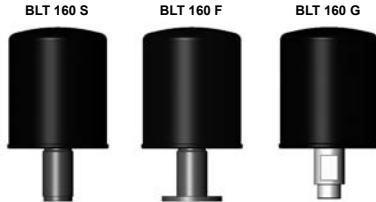

Tank Breather Filter and Dehumidifier BLT up to 270 l/min



1. TECHNICAL SPECIFICATIONS

1.1 FILTER HOUSING

Construction

The filters consist of a spin-on can which screws onto a connection tube which is fitted to the oil tank. The connection can either be a flange, weld or threaded version.

1.2 REPLACEMENT CARTRIDGES

The replacement cartridges comply with all relevant ISO test criteria.

1.3 SEALS

Cardboard for flange model

1.4 SPECIAL MODELS AND ACCESSORIES

On request

1.5 SPARE PARTS

See Original Spare Parts List

1.6 CERTIFICATES AND APPROVALS

On request

1.7 FILTER SPECIFICATIONS

Temperature range	-30 °C to +100 °C
Material of connection tube	Steel
Material of spin-on can	Sheet steel

1.8 COMPATIBILITY WITH HYDRAULIC FLUIDS ISO 2943

The tank breather filter/dehumidifier BLT is suitable for use with all standard mineral and lubrication oils.

1.9 CHANGING INTERVALS

The filter elements or filters must be replaced as frequently as the fluid filters, but at least every 6 months.

Symbol

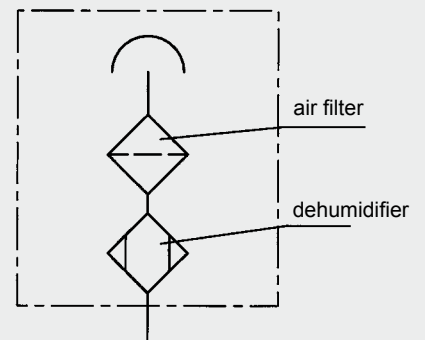

2. MODEL CODE

2.1 COMPLETE FILTER

Filter type _____ **BLT**
Filter material of element _____ **M** (molecular sieve)
Size of filter _____ **160**
Type and size of connection _____ **F 3 W 1 . X**

Type	Connection	Filter size
		160
F	Flange connection	●
S	Weld connection	●
G	Threaded connection	●

Filtration rating in µm _____ **3** (3 µm absolute)
Type of clogging indicator _____ **W** (without port for clogging indicator)
Type code _____ **1**
Modification number _____ **X** (the latest version is always supplied)

2.2 REPLACEMENT ELEMENT: 0160 MU 003 M

3. FILTER CALCULATION / SIZING

Differential pressure across breather filter

The differential pressure (with clean element) is shown in the graph below.

BLT 160

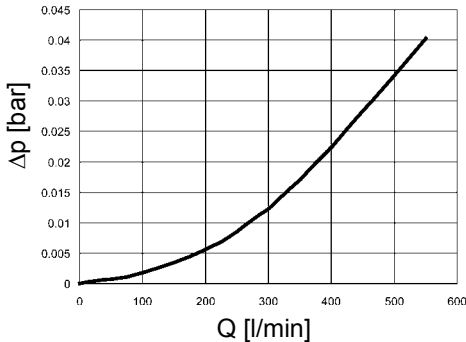

3.1 SIZING GUIDELINES

The rate at which contamination and humidity enters a hydraulic system can be considerably reduced by using efficient tank breather filtration.

NOTE:

Incorrectly sized breather filters can place additional strain on the system and reduce the service life of hydraulic filter elements.

For optimum sizing the following should therefore be observed:

- Filtration rating of air breather filter \leq filtration rating of hydraulic filter
- Only use air breather filters with an absolute retention rate ($d_{100} \leq x \mu\text{m}$; x = given filtration rating)
- Max. permissible initial pressure loss: 0.01 bar (with a clean filter element and calculated air flow rate)
- Determination of the calculated air flow rate:
 $Q_A = f_5 \times Q_p$
 Q_A = air flow rate for sizing purposes in l/min
 f_5 = factor for operating conditions
 Q_p = max. flow rate of the hydraulic pump in l/min

For Factor f_5 , see table on p. 275, ELF Tank Breather Filter, E 7.404.0/06.07.

3.2 WATER RETENTION CAPACITY

Temperature	Rel. humidity	gH_2O
0 °C	30%	190
15 °C	60%	210
25 °C	90%	230

4. DIMENSIONS

Flange version

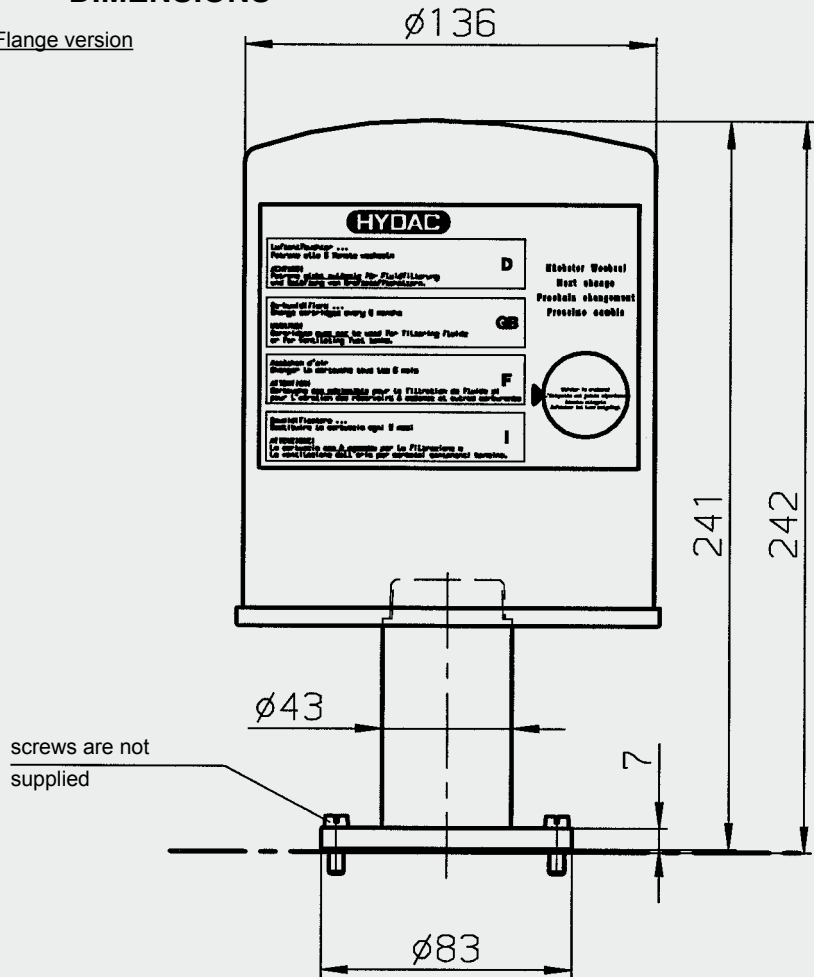

Interface to DIN 24557/T2

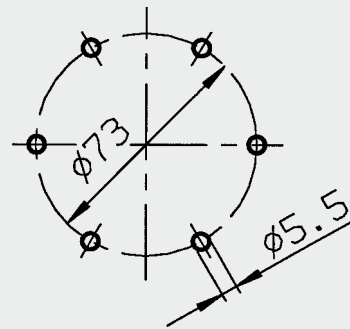

Weld version

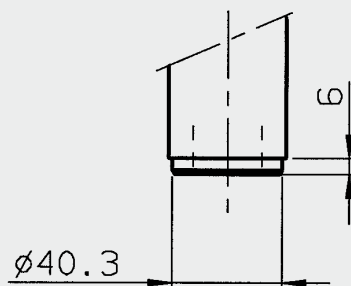

Threaded version

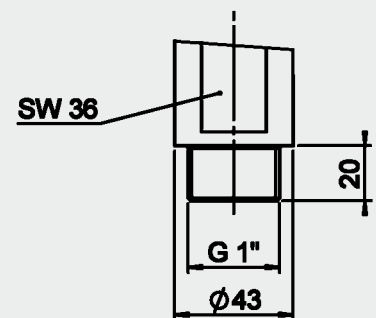

NOTE

The information in this brochure relates to the operating conditions and applications described. For applications or operating conditions not described, please contact the relevant technical department. Subject to technical modifications.

HYDAC Filbertechnik GmbH
 Industriegebiet
 D-66280 Sulzbach/Saar
 Tel.: 0 68 97 / 509-01
 Fax: 0 68 97 / 509-300
 Internet: www.hydac.com
 E-Mail: filter@hydac.com