

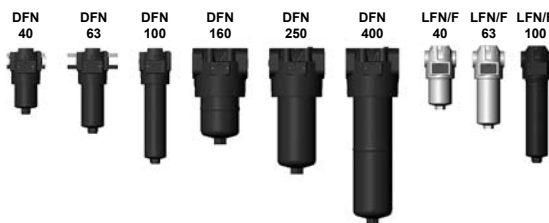

Inline Filter DFN/LFN/LFNF to DIN 24550

up to 400 l/min, up to 400 bar



1. TECHNICAL SPECIFICATIONS

1.1 FILTER HOUSING

Construction

The filter housings are designed in accordance with international regulations. They consist of a filter head with a screw-in filter bowl.

Standard equipment:

- without bypass valve
- connection for a clogging indicator

1.2 FILTER ELEMENTS

Hydac filter elements are validated and their quality is constantly monitored according to the following standards:

- ISO 2941
- ISO 2942
- ISO 2943
- ISO 3724
- ISO 3968
- ISO 11170
- ISO 16889

Contamination retention capacities in g

LFN, LFNF DFN	Betamicon® (BN4HC)			
	3 µm	6 µm	10 µm	25 µm
40	5.2	5.6	6.3	7.0
63	9.2	9.9	11.1	12.8
100	15.4	16.5	18.6	20.6
160	27.5	29.3	33.1	36.7
250	46.0	49.0	55.2	61.3
400	76.2	81.3	91.4	101.5

LFN, LFNF	Betamicon® (BH4HC)			
	3 µm	6 µm	10 µm	25 µm
40	4.1	4.4	5.2	6.2
63	7.3	7.9	9.2	11.2
100	12.2	13.2	15.5	18.9
160	21.8	23.9	27.8	33.8
250	38.1	41.7	48.6	59.0
400	63.6	69.5	81.0	98.3

Filter elements are available with the following pressure stability values:

Betamicon® (BN4HC):	20 bar
Betamicon® (BH4HC):	160 bar
Wire mesh (W/HC):	20 bar

1.3 FILTER SPECIFICATIONS

Nominal pressure	100 bar : all LFN and LFNF 210 bar : DFN 160, 400 400 bar : DFN 40, 63, 100, 250
Fatigue strength	at nominal pressure 10 ⁶ load cycles from 0 to nominal pressure
Temperature range	-30 °C up to +100 °C (-30 °C up to -10 °C = 200 bar - DFN only)
Material of filter head (and cover plate)	EN-GJS-400-15: DFN Aluminium : LFN/F
Material of filter bowl (tube)	Steel : DFN Aluminium : LFN/F 40, 63 Steel : LFN/F 100
Type of clogging indicator	VM (differential pressure indication up to 210 bar operating pressure - not for LZ) VD (differential pressure indication up to 420 bar operating pressure)
Pressure setting of clogging indicator	5 bar (others on request)
Cracking pressure of bypass (optional)	7 bar (others on request)

1.4 SEALS

NBR (= Perbunan)

1.5 MOUNTING

As inline filter

1.6 SPECIAL MODELS AND ACCESSORIES

- with bypassventil
- FPM seals

1.7 SPARE PARTS

See Original Spare Parts List

1.8 CERTIFICATES AND APPROVALS

On request

1.9 COMPATIBILITY WITH HYDRAULIC FLUIDS ISO 2943

- Hydraulic oils H to HLPD DIN 51524
- Lubrication oils DIN 51517, API, ACEA, DIN 51515, ISO 6743
- Compressor oils DIN 51506
- Biodegradable operating fluids VDMA 24568 HETG, HEES, HEPG
- Non-flam operating fluids HFA, HFB, HFC and HFD
- Operating fluids with high water content (>50% water content) on request

1.10 IMPORTANT INFORMATION

- Filter housing must be earthed
- When using electrical clogging indicators, the electrical power supply to the system must be switched off before removing the clogging indicator connector

Symbol for hydraulic systems DFN / LFN

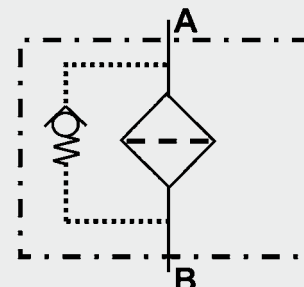

LFNF

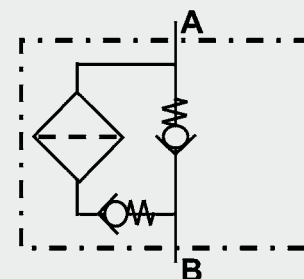

2. MODEL CODE (also order example)

DFN BN/HC 250 S F 10 D 1 . X /-L24

2.1 COMPLETE FILTER

Filter type

DFN, LFN, LFNF

Filter material of element

BN/HC Betamicon® (BN4HC) BH/HC Betamicon® (BH4HC)
W/HC Wire mesh

Size of filter or element

DFN: 40*, 63, 100, 160*, 250, 400 (* on request)
LFN/F: 40, 63, 100

Operating pressure

I = 100 bar (LFN and LFNF)
L = 210 bar (DFN 160, 400)
S = 400 bar (DFN 40, 63, 100, 250)

Type and size of port

to DIN 24550 (●), possible ports (x)

Type	Port	Filter size					
		40	63	100	160	250	400
B	G 1/2	●	x	x			
C	G 3/4	x	●	x			
D	G 1	x	x	●			
E	G 1 1/4				●	x	x
F	G 1 1/2				x	●	x
K	DN 40*				x	x	●

*Flange SAE, 6000 PSI

Filtration rating in µm

BN4HC, BH4HC: 3, 6, 10, 25 W/HC: 25, 50, 100, 200

Type of clogging indicator

Y plastic blanking plug in indicator port
A steel blanking plug in indicator port
B visual
C electrical
D visual and electrical
LZ visual-mechanical / electrical

for other clogging indicators see brochure no. E 7.050../..

Type code

1 DFN
2 LFN / LFNF

Modification number

X the latest version is always supplied

Supplementary details

B. bypass cracking pressure (e. g.: B7 = 7 bar); no details = without bypass valve
L... light with appropriate voltage (24V, 48V, 110V, 220V)] only for clogging
LED 2 light emitting diodes up to 24 Volt] indicators Type D
AV LZ indicator with plug to AUDI and VW specification
BO LZ indicator with plug and pin connection to BMW and Opel specification (M12x1)
CN LZ indicator with plug to DIN 43651 with 3 LEDs (CNOMO standard)
DB LZ indicator with plug to DIN 43651 with 3 LEDs (Daimler-Benz standard)
D4C LZ indicator with plug and pin connection to Daimler-Chrysler specification and cold start suppression 30 °C
BO-LED as for BO, but with progressive diode strip
SO368 inlet and outlet G 1/2 (without RI connection; only for DFN 40, 63, 100)
V FPM seals
W suitable for HFA and HFC emulsions

0250 DN 010 BN4HC /-V

2.2 REPLACEMENT ELEMENT

Size

0040, 0063, 0100, 0160, 0250, 0400

Type

DN

Filtration rating in µm

BN4HC, BH4HC: 003, 006, 010, 025 W/HC: 025, 050, 100, 200

Filter material

BN4HC, BH4HC, W/HC

Supplementary details

V (for descriptions, see point 2.1)

2.3 REPLACEMENT CLOGGING INDICATOR

VM 5 D . X /-L24

Type

VM differential pressure indicator up to 210 bar operating pressure (not for type LZ)
VD differential pressure indicator up to 420 bar operating pressure

Pressure setting

5 5 bar standard, others on request

Type of clogging indicator (see point 2.1)

Modification number

X the latest version is always supplied

Supplementary details

L..., LED, V, W (for descriptions, see point 2.1)

3. FILTER CALCULATION / SIZING

The total pressure drop of a filter at a certain flow rate Q is the sum of the housing Δp and element Δp and is calculated as follows:

$$\Delta p_{\text{total}} = \Delta p_{\text{housing}} + \Delta p_{\text{element}}$$

$$\Delta p_{\text{housing}} = (\text{see point 3.1})$$

$$\Delta p_{\text{element}} = Q \cdot \frac{SK^*}{1000} \cdot \frac{\text{viscosity}}{30}$$

(*see point 3.2)

For ease of calculation, our Filter Sizing Program is available on request free of charge.

NEW: Sizing online at www.hydac.com

3.1 Δp -Q HOUSING GRAPHS BASED ON ISO 3968

The housing graphs apply to mineral oil with a density of 0.86 kg/dm³ and a kinematic viscosity of 30 mm²/s. In this case, the differential pressure changes proportionally to the density.

DFN (40), 63, 100
LFN 40, 63, 100

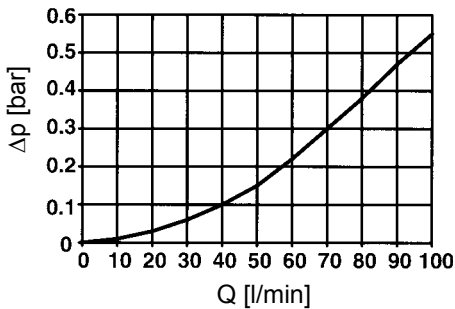

LFNF 40, 63, 100

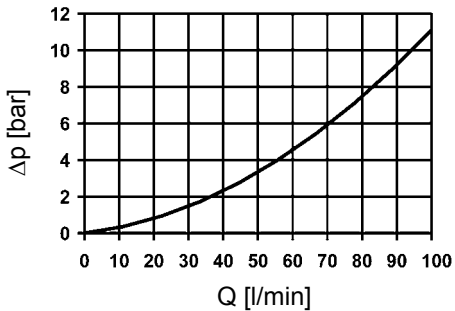

DFN 160, 250, 400

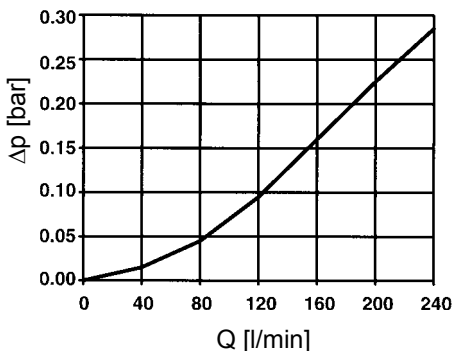

3.2 GRADIENT COEFFICIENTS (SK) FOR FILTER ELEMENTS

The gradient coefficients in mbar/(l/min) apply to mineral oils with a kinematic viscosity of 30 mm²/s. The pressure drop changes proportionally to the change in viscosity.

LFN/F	BH4HC				W/HC
DFN	3 μm	5 μm	10 μm	20 μm	-
40	40.4	24.8	16.4	10.9	0.966
63	29.0	18.2	11.7	7.6	0.540
100	19.0	11.7	7.7	5.3	0.325
160	8.0	5.1	3.8	2.5	0.168
250	5.4	3.4	2.8	1.9	0.101
400	3.4	2.1	1.7	1.1	0.068

BN4HC: DFN / LFN / LFN 40

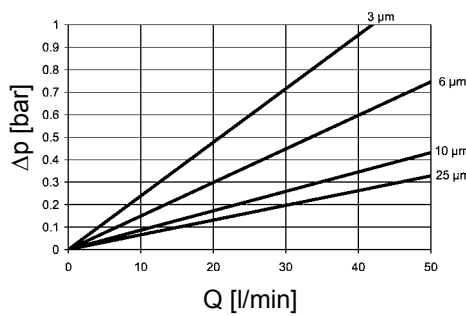

BN4HC: DFN / LFN / LFN 160

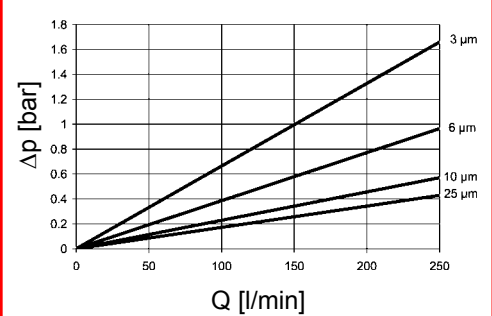

BN4HC: DFN / LFN / LFN 63

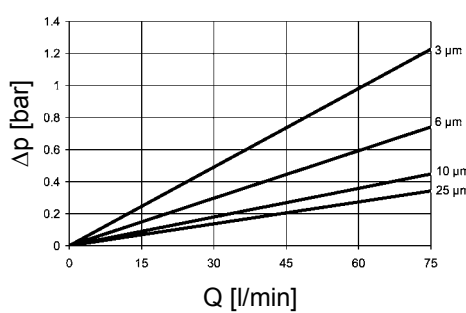

BN4HC: DFN / LFN / LFN 250

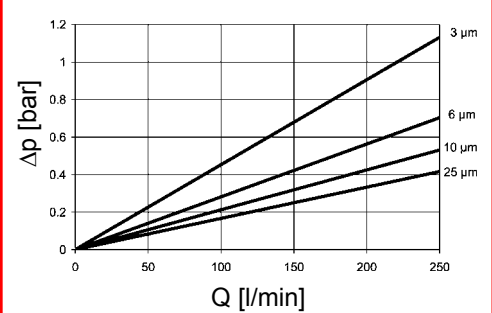

BN4HC: DFN / LFN / LFN 100

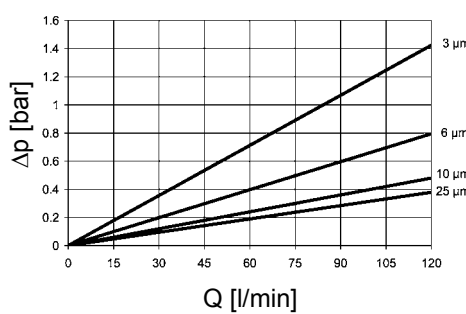

BN4HC: DFN / LFN / LFN 400

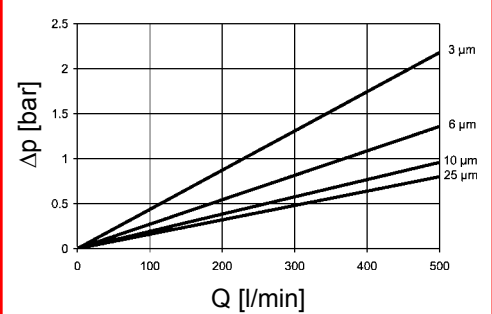

4. DIMENSIONS

LFN, LFNF

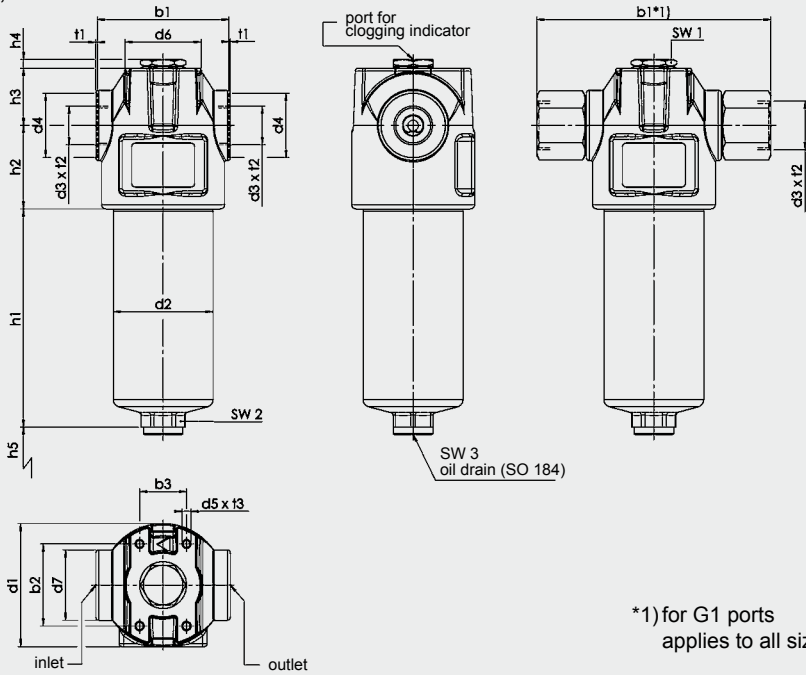

Type	Weight incl. element [kg]	Volume of pressure chamber [l]
LFN 40	1.45	0.26
LFN 63	1.8	0.40
LFN 100	4.3	0.50
LFNF 40	1.45	0.26
LFNF 63	1.8	0.40
LFNF 100	4.3	0.50
DFN 40	5.0	0.22
DFN 63	6.0	0.33
DFN 100	6.25	0.50
DFN 160	20.0	1.10
DFN 250	22.0	1.70
DFN 400	26.5	2.70

Type	b1	b2	b3	d1	d2	d3	d4	d5	d6	d7	h1	h2	h3	h4	h5	SW1	SW2	t1	t2	t3
LFN 40	90	56	32	84	68	G 1/2	34	M6	52	48	90	57	39	6	75	27	27	1	14	9
LFN 63	90	56	32	84	68	G 3/4	44	M6	52	48	150	57	39	6	75	27	27	1	17	9
LFN 100	160 ^{*1)}	56	32	84	65	G 1	-	M6	52	48	245.5	57	39	6	75	27	27	-	24.5	9
LFNF 40	90	56	32	84	68.2	G 1/2	34	M6	52	48	90	57	39	6	75	27	27	1	14	9
LFNF 63	90	56	32	84	68.2	G 3/4	44	M6	52	48	150	57	39	6	75	27	27	1	17	9
LFNF 100	160 ^{*1)}	56	32	84	65	G 1	-	M6	52	48	245.5	57	39	6	75	27	27	-	24.5	9

DFN 40 - 100

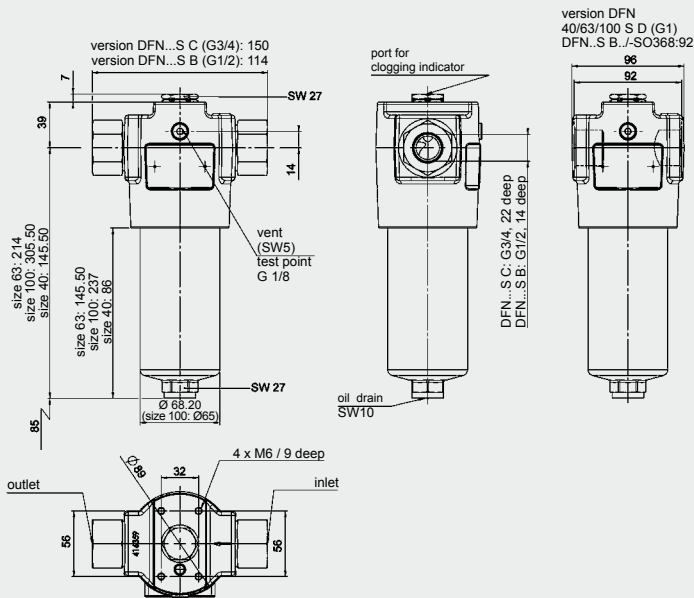

DFN 160 - 400

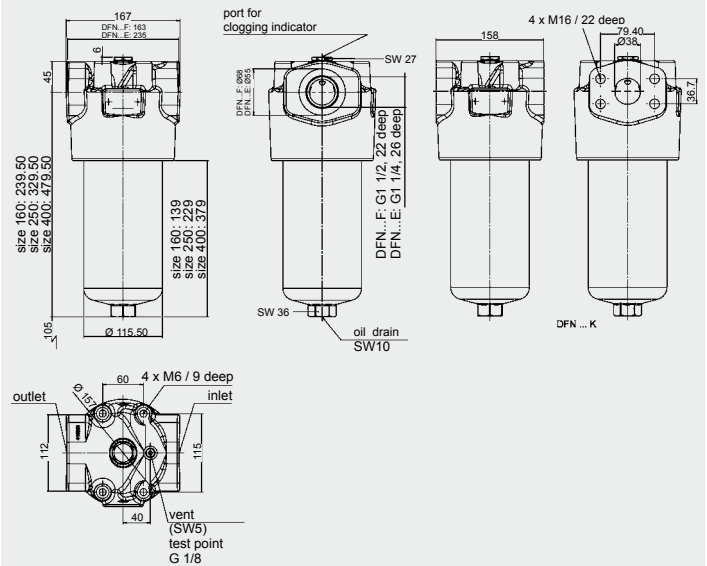

NOTE

The information in this brochure relates to the operating conditions and applications described.

For applications or operating conditions not described, please contact the relevant technical department.

Subject to technical modifications.

HYDAC Filbertechnik GmbH
 Industriegebiet
 D-66280 Sulzbach/Saar
 Tel.: 0 68 97 / 509-01
 Fax: 0 68 97 / 509-300
 Internet: www.hydac.com
 E-Mail: filter@hydac.com