

up to 40 l/min
up to 350 bar

FUNCTION

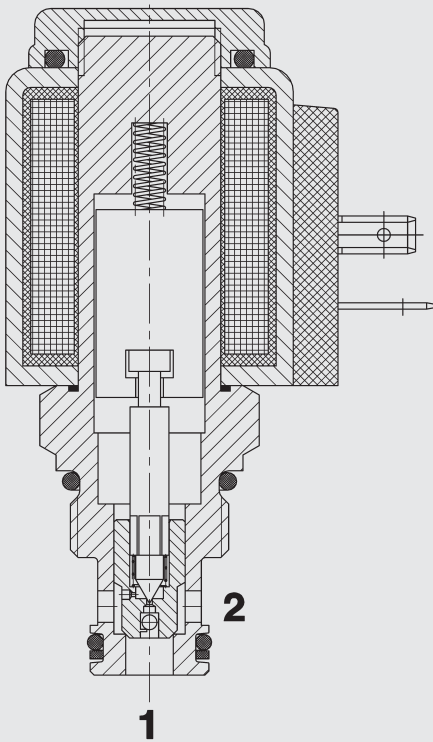

When the solenoid coil is not energized, the valve is closed from port 2 to port 1. In the reverse direction there is free flow through the valve. The valve spool opens at a differential pressure of approx. 1.5 bar (check function). When the solenoid coil is energized, there is free flow through the valve in both directions.

2/2 Solenoid Directional Valve Cartridge Valve – 350 bar SEAT Type - Pilot Operated Normally Closed (Reverse Flow)

WSM06020ZR-01

GENERAL

- Long life and low noise level due to oil-immersed solenoid armature.
- Electro-magnetic actuation available in all standard international DC and AC voltages and many electrical connection types available.
- Minimal wear and long life due to hardened and polished control elements.
- In the closed position the flow paths are shut off by means of a cone seat.
- Solenoid coils can be rotated through 360° and replaced without opening the hydraulic system.
- Surfaces are zinc-plated.
- Built-in seals protect solenoid coils from water penetration.
- Compact construction enables space-saving installation in connection housings and control blocks.

SPECIFICATIONS

Operating pressure:	max. 350 bar	
Flow rate:	max. 40 l/min	
Internal leakage:	leakage-free	
Temperature range of operating fluid:	-20 °C to +120 °C	
Ambient temperature range:	-20 °C to +60 °C	
Type of voltage:	DC solenoid, AC voltage is rectified using a bridge rectifier built into the coil	
Nominal voltage (at 20 °C):	1.5 A at 12 V DC 0.8 A at 24 V DC	
Voltage tolerance:	-15% to +15%	
Switch-on time:	100% (continuous)	
Switching time:	on: approx. 35 ms off: approx. 50 ms	
Operating fluid:	hydraulic oil to DIN 51524 Part 1 and 2	
Viscosity range:	10 mm ² /s to 420 mm ² /s is recommended	
Filtration:	max. permissible contamination level of the operating fluid to ISO 4406 Class 21/19/16	
Mounting position:	optional	
Materials:	valve body:	high tensile steel
	closing elements:	hardened and polished steel
	seals:	NBR (standard) FKM (optional) back-up ring in PTFE
Cavity:	06020	
Weight:	Valve complete:	0.33 kg
	Coil only:	0.19 kg

DIMENSIONS

1" / 25.5 mm HEX
Torque 5^{±2} Nm

After loosening mounting nut, coil can be rotated through 360° and removed.

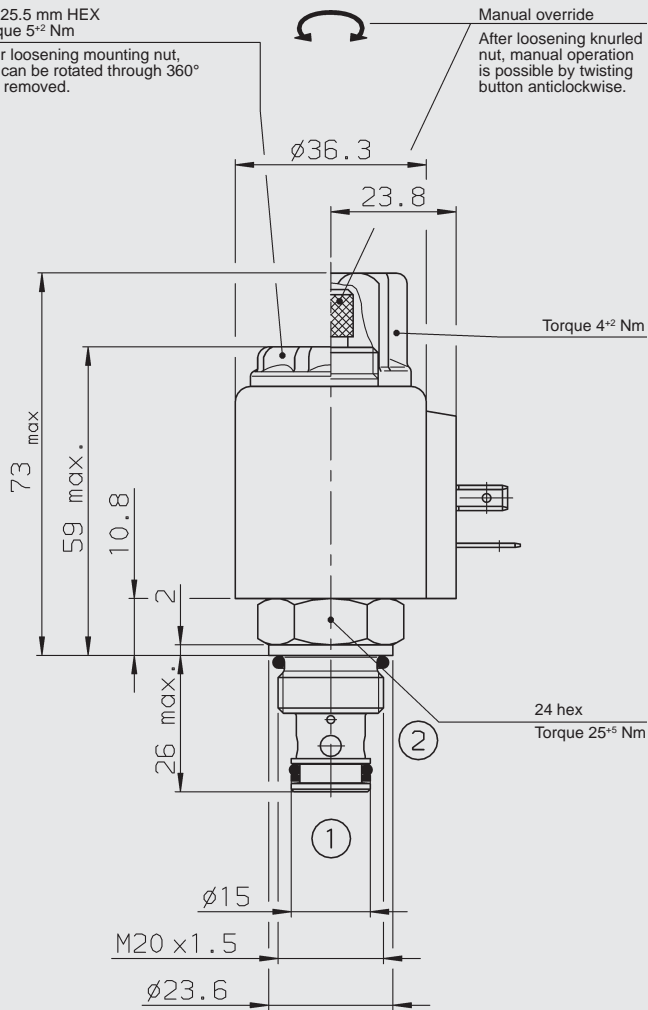

MODEL CODE

WSM 06020 ZR - 01 M - C - N - 24 DG

Designation (Directional seat valve, metric)

Cavity 06020 = 2-way cavity

Function code

Type 01 = standard model

Manual override no details = without manual override
M = manual override

Type of connection C = cartridge valve

Seals N = NBR
V = FKM

Nominal voltage for actuating solenoid

DC voltages

10 = 10 V DC
12 = 12 V DC
24 = 24 V DC
36 = 36 V DC
48 = 48 V DC
110 = 110 V DC only with plug to EN 175301-803

AC voltages (bridge rectifier built into the coil)

24 = 24 V AC
115 = 115 V AC
230 = 230 V AC

other voltages on request

Electrical connection types of the actuating solenoid

DC: DG = plug to EN 175301-803
DL = with 2 flying leads, 457 mm long
0.75 mm² cable cross-section
DW = Weather Pack plug no. 12010973 on 2 leads, 241 mm long
DT = AMP Junior Timer, 2-pole, radial
DK = KOSTAL threaded connection M27x1

AC: AG = plug to EN 175301-803

other connection types on request

CAVITY

06020

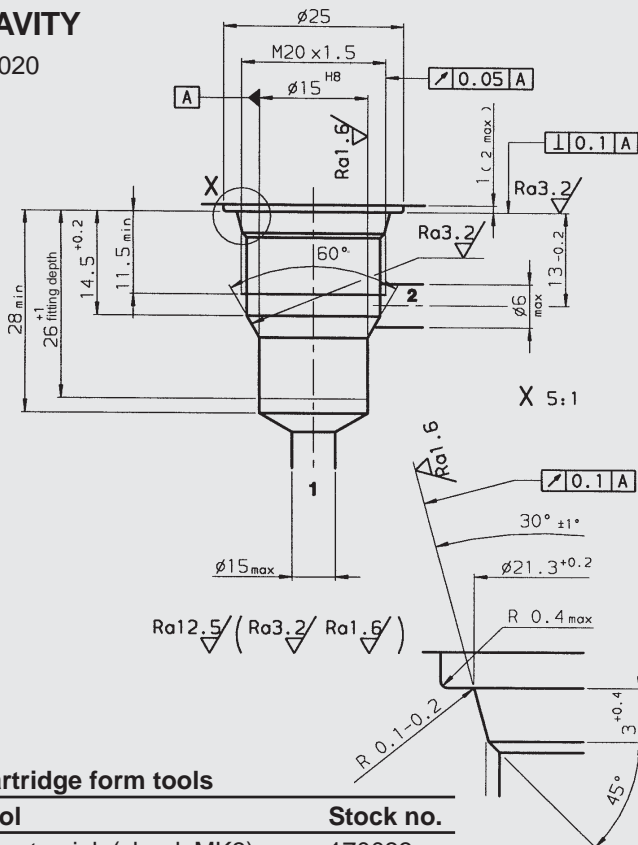

Cartridge form tools

Tool	Stock no.
Countersink (shank MK3)	170033
Reamer (shank MK2)	1000768

Subject to technical modifications.

Standard models

Model code	Stock no.
WSM06020ZR-01-C-N-24DG	3055535
WSM06020ZR-01-C-N-230AG	3055533

Inline connection housings

Code	Stock no.	Material	Ports
R06020-01X-01	275266	Steel, zinc-plated	G 3/8

For other connection housings, see brochure no. E 5.252.

"Connection Housings for Cartridge Valves".

PRESSURE DROP

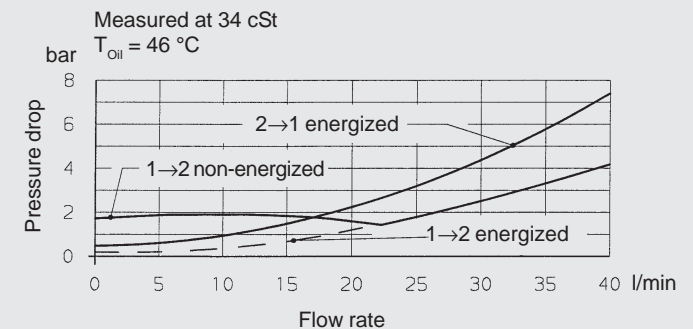

NOTE

The information in this brochure relates to the operating conditions and applications described.

For applications or operating conditions not described, please contact the relevant technical department.

Subject to technical modifications.

HYDAC Fluidtechnik GmbH

Justus-von-Liebig-Str.

D-66280 Sulzbach/Saar

Tel: 0 68 97 /509-01

Telefax: 0 68 97 /509-598

E-Mail: flutec@hydac.com