

up to 40 l/min
up to 350 bar

FUNCTION

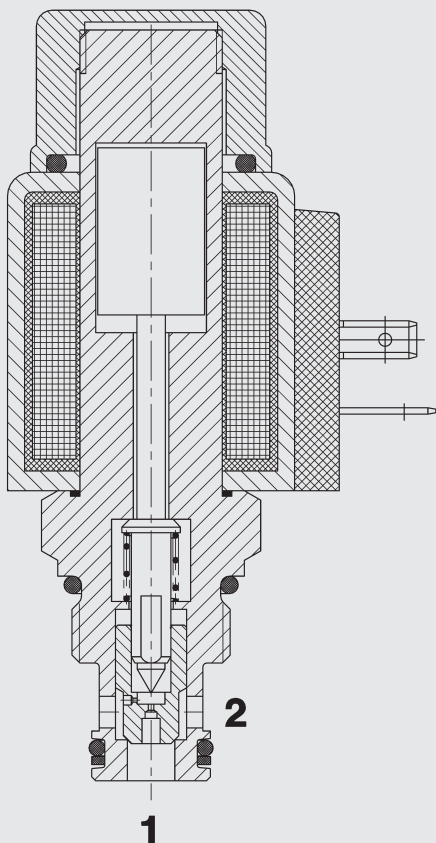

When the solenoid coil is not energized, there is free flow through the valve from port 2 to port 1. Flow from port 1 to port 2 is severely restricted in this mode.

When the solenoid coil is energized, the valve is closed from port 2 to port 1.

In the reverse direction there is free flow through the valve when the pressure force on the spool exceeds the solenoid force (approx. 9 to 20 bar).

2/2 Solenoid Directional Valve Cartridge Valve – 350 bar SEAT Type - Pilot Operated Normally Open

WSM06020Y-01

GENERAL

- Long life and low noise level due to oil-immersed solenoid armature.
- Electro-magnetic actuation available in all standard international DC and AC voltages and many electrical connection types available.
- Minimal wear and long life due to hardened and polished control elements.
- In the closed position the flow paths are shut off by means of a cone seat.
- Solenoid coils can be rotated through 360° and replaced without opening the hydraulic system.
- Surfaces are zinc-plated.
- Built-in seals protect solenoid coils from water penetration.
- Compact construction enables space-saving installation in connection housings and control blocks.

SPECIFICATIONS

Operating pressure:	max. 350 bar
Flow rate:	max. 40 l/min
Internal leakage:	leakage-free
Temperature range of operating fluid:	-20 °C to +120 °C
Ambient temperature range:	-20 °C to +60 °C
Type of voltage:	DC solenoid, AC voltage is rectified using a bridge rectifier built into the coil
Nominal voltage (at 20 °C):	1.5 A at 12 V DC 0.8 A at 24 V DC
Voltage tolerance:	-15% to +15%
Switch-on time:	100% (continuous)
Switching time::	on: approx. 50 ms off: approx. 35 ms
Operating fluid:	hydraulic oil to DIN 51524 Part 1 and 2
Viscosity range:	10 mm ² /s to 420 mm ² /s is recommended
Filtration:	max. permissible contamination level of the operating fluid to ISO 4406 Class 21/19/16
Mounting position:	optional
Materials:	valve body: high tensile steel closing elements: hardened and polished steel seals: NBR (standard) FKM (optional) back-up ring in PTFE
Cavity	06020
Weight:	Valve complete: 0.33 kg Coil only: 0.19 kg

DIMENSIONS

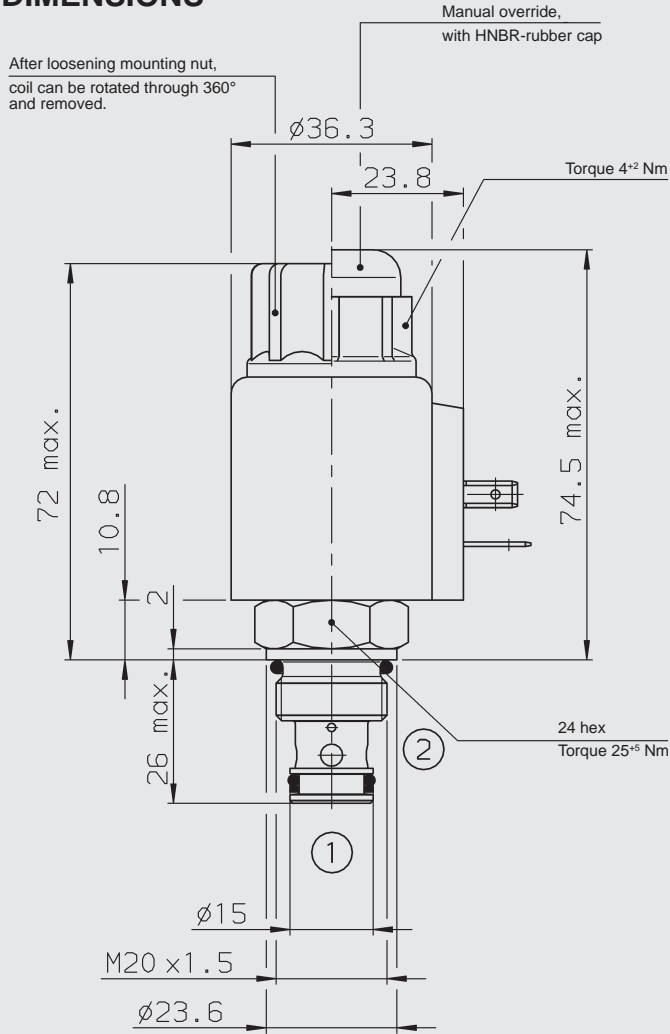

Subject to technical modifications

MODEL CODE

WSM 06020 Y - 01 M - C - N - 24 DG

Designation (Directional seat valve, metric)

Cavity 06020 = 2-way cavity

Function code

Type 01 = standard model

Manual override no details = without manual override
M = manual override

Type of connection C = cartridge valve

Seals N = NBR
V = FKM

Nominal voltage for actuating solenoid

DC voltages

10 = 10 V DC
12 = 12 V DC
24 = 24 V DC
36 = 36 V DC
48 = 48 V DC
110 = 110 V DC only with plug to EN 175301-803

AC voltages (bridge rectifier built into the coil)

24 = 24 V AC
115 = 115 V AC
230 = 230 V AC

other voltages on request

Electrical connection types of the actuating solenoid

DC: DG = plug to EN 175301-803

DL = with 2 flying leads, 457 mm long
0.75 mm² cable cross-section

DW = Weather Pack plug no. 12010973 on 2 leads, 241 mm long

DT = AMP Junior Timer, 2-pole, radial

DK = KOSTAL threaded connection M27x1

AC: AG = plug to EN 175301-803

other connection types on request

CAVITY

06020

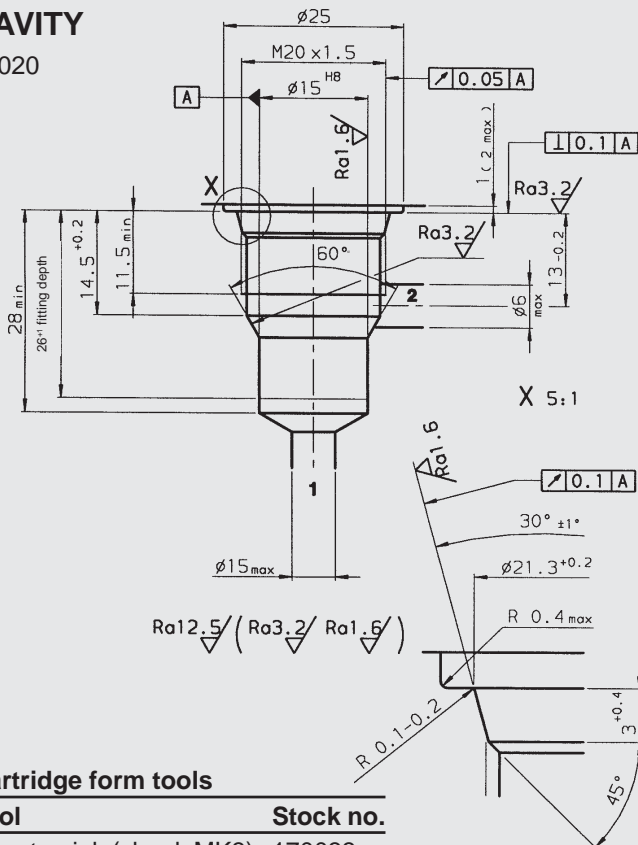

Cartridge form tools

Tool	Stock no.
Countersink (shank MK3)	170033
Reamer (shank MK2)	1000768

Subject to technical modifications

Standard models

Model code	Stock no.
WSM06020Y-01-C-N-24DG	3056077
WSM06020Y-01-C-N-230AG	3056075

Inline connection housings

Model code	Stock no.	Material	Ports
R06020-01X-01	275266	Steel, zinc-plated	G 3/8

For other connection housings, see brochure no. E 5.252.

"Connection Housings for Cartridge Valves".

PRESSURE DROP

Measured at 34 cSt

T_{oil} = 46 °C

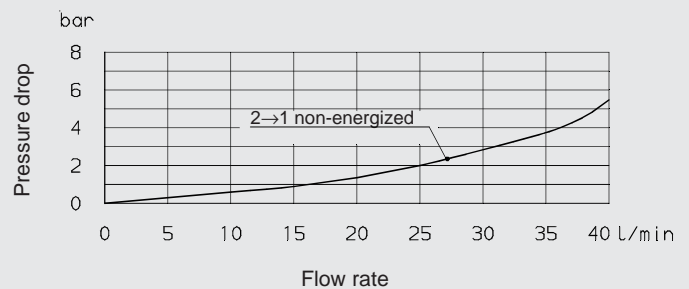

NOTE

The information in this brochure relates to the operating conditions and applications described.

For applications or operating conditions not described, please contact the relevant technical department.

Subject to technical modifications.

HYDAC Fluidtechnik GmbH

Justus-von-Liebig-Str.

D-66280 Sulzbach/Saar

Tel: 0 68 97 /509-01

Telefax: 0 68 97 /509-598

E-Mail: flutec@hydac.com