



## Electronic Pressure Switch

### EDS 300

with Approvals for Shipping

#### Description:

The EDS 300 is a compact, electronic pressure switch with digital display. The pressure measurement is based on a strain gauge sensor cell in stainless steel. All parts in contact with the medium are in stainless steel, and are welded together. Since no seals are required in the sensor interior, leakage is eliminated.

Two relay switch outputs with N/O function and an additional analogue output signal (4 .. 20 mA) enable the pressure switch to be incorporated into the most modern control concepts. The switching points and the corresponding hystereses can easily be adjusted via the keypad.

For optimum adaptation to a particular application, the unit has many additional adjustment parameters, e.g. switching direction of the relays or switching delay times.

Areas of application are pressure or maximum value monitoring on marine transmissions, diesel engines, pumps and general hydraulic and pneumatic systems.

#### Approvals:

- American Bureau of Shipping



- Lloyds Register of Shipping



- Det Norske Veritas



- Germanischer Lloyd



- Bureau Veritas



Other approvals on request

#### Technical specifications:

##### Input data

Measuring ranges	-1..5; 6; 16; 40; 100; 250; 400; 600 bar
Overload pressures	15; 15; 32; 80; 200; 500; 800; 1000 bar
Burst pressure	100; 100; 200; 200; 500; 1000; 2000; 2000 bar
Mechanical connection	G1/4 A DIN 3852
Torque value	20 Nm
Parts in contact with medium	Mech. connection: Stainless steel Seal: FPM

##### Output data

Accuracy to DIN 16086, Max. setting (display, analogue output)	≤ ± 0.5 % FS typ. ≤ ± 1 % FS max.
Repeatability	≤ ± 0.5 % FS max.
Temperature drift	≤ ± 0.03 % FS / °C max. zero point ≤ ± 0.03 % FS / °C max. range

##### Analogue output

Signal	4 .. 20 mA	ohmic resistance ≤ 400 Ω
--------	------------	--------------------------

##### Switching outputs

Type	relay contacts (N/O)
Switching voltage	max. 60 V AC / DC
Switching current	max. 1 A per switching output
Switching output	max. 30 W / 30 VA (for inductive load, use varistors)
Switching cycles	20 million at minimum load 0.5 million at maximum load
Reaction time	approx. 10 ms

##### Ambient conditions

Compensated temperature range	-10 .. +70 °C
Operating temperature range	-25 .. +80 °C
Storage temperature range	-40 .. +80 °C
Fluid temperature range	-25 .. +80 °C
CE mark	EN 61000-6-1 / 2 / 3 / 4
Vibration resistance to DIN EN 60068-2-6 at 10 .. 500 Hz	5 .. 25 Hz: 3.2 mm 25 .. 500 Hz: 4 g
Shock resistance to DIN EN 60068-2-29 (1 ms)	≤ 50 g
Protection class to DIN 40050	IP 65

##### Other data

Supply voltage	20 .. 32 V DC
Current consumption	approx. 100 mA (inactive switch output)
Display	4-digit, LED, 7 segment, red, height of digits 9.2 mm
Weight	approx. 300 g

Note: Reverse polarity protection of the supply voltage, excess voltage, override, short circuit protection are provided.  
FS (Full Scale) = relative to the complete measuring range

## Setting options:

All the settings available on the EDS 300 are combined in two easy-to-follow menus. To prevent unauthorised adjustment of the unit a program disable can be activated.

## Setting ranges for the switch outputs:

Switch point function

Meas. range in bar	Switch point in bar	Hysteresis in bar	Increment* in bar
-1 .. 5	-0.85 .. 5	-0.95 .. 4.9	0.05
0 .. 6	0.15 .. 6	0.05 .. 5.9	0.05
0 .. 16	0.3 .. 16	0.1 .. 15.8	0.1
0 .. 40	0.6 .. 40	0.2 .. 39.6	0.2
0 .. 100	1.5 .. 100	0.5 .. 99.0	0.5
0 .. 250	3.0 .. 250	1.0 .. 248	1.0
0 .. 400	6.0 .. 400	2.0 .. 396	2.0
0 .. 600	15.0 .. 600	5.0 .. 590	5.0

\* All ranges given in the table are adjustable by the increments shown.

## Additional functions:

- Scale of the display range adjustable (bar or psi)
- Switching direction of the relays adjustable (N/C or N/O function)
- Switch-on and switch-back delay adjustable from 0.0 .. 75.0 seconds
- Choice of display (actual pressure, peak value, switching point 1, switching point 2, display off)
- Subsequent correction of zero point in the range  $\pm 3\%$  FS possible

## Pin connections:

DIN 43651

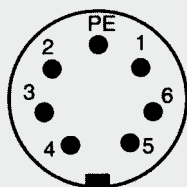

Pin	EDS 347-4
1	+U <sub>B</sub>
2	Centre relay 1 and 2
3	Relay contact 1 (SP 1)
4	0 V
5	Analogue
6	Relay contact 2 (SP 2)
⊥	PE

## Model code:

EDS 3 4 7 - 4 - XXX - SXX

### Mechanical connection

4 = G1/4 A DIN 3852 (male)

### Electrical connection

7 = 6 pole + PE, DIN 43651  
(connector ZBE 10 not supplied)

### Output

4 = 2 switching outputs and 1 analogue output

### Pressure ranges in bar

006; 016; 040; 100; 250; 400; 600

### Modification number

S00 = version in bar (except -1 .. 5)

S13 = vacuum version -1 .. 5 bar (in conjunction with pressure range 006)

### Notes:

Special models on request.

For units with a different modification number, please read the label or the technical amendment details supplied with the unit.

### Accessories:

Appropriate accessories, such as electrical connectors, mechanical connection adaptors, clamps for wall-mounting etc can be found in the Accessories section.

## Dimensions:

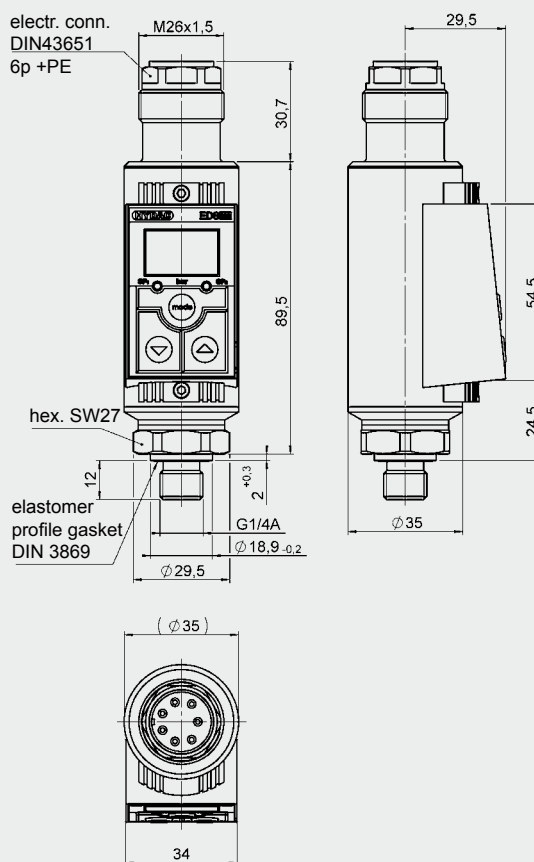

### Note:

The information in this brochure relates to the operating conditions and applications described.

For applications and operating conditions not described, please contact the relevant technical department.

Subject to technical modifications.

**HYDAC** ELECTRONIC GMBH  
Hauptstraße 27, D-66128 Saarbrücken  
Telephone +49 (0)6897 509-01  
Fax +49 (0)6897 509-1726  
E-Mail: electronic@hydac.com  
Internet: www.hydac.com



## Electronic Pressure Switch

EDS 4400  
Programmable

### Description:

The programmable electronic pressure switch in the EDS 4400 series has been specially developed to combine the advantages of a compact, robust and cost-effective unit with the benefits of a programmable pressure switch.

The EDS 4400 can be easily programmed using the HPG 3000 programming unit. If the programming unit is disconnected from the EDS 4400, the pressure switch retains all the settings. This prevents unauthorised adjustment of the settings.

The following parameters can be changed:

- Switching point
- Hysteresis
- Switching direction (N/O / N/C)
- Switching delay times

The EDS 4400 is suitable for high pressure applications (over 40 bar) and has a pressure measurement cell with thin-film strain gauge on a stainless steel membrane.

In contrast to pressure switches which are permanently pre-set according to customer requirements, the programmable EDS 4400 is highly versatile and replaces a wide range of models, which benefits stockholding.

### Special features:

- Option of 1 or 2 switching outputs
- Option of PNP or NPN switching outputs
- High switching output capacity
- Accuracy  $\leq \pm 1\%$  FS
- Individual programming
- Compact and robust design
- Also available in ATEX version for potentially explosive locations

### Technical specifications:

Input data	
Measuring ranges	40; 100; 250; 400; 600 bar
Overload pressures	80; 200; 500; 800; 1000 bar
Burst pressure	200; 500; 1000; 2000; 2000 bar
Mechanical connection	G1/4 A DIN 3852
Torque value	20 Nm
Parts in contact with medium	Mech. connection: Stainless steel Seal: FPM
Output data	
Accuracy to DIN 16086,	$\leq \pm 0.5\%$ FS typ.
Max. setting	$\leq \pm 1\%$ FS max.
Repeatability	$\leq \pm 0.1\%$ FS max.
Temperature drift	$\leq \pm 0.03\%$ FS / °C max. zero point $\leq \pm 0.03\%$ FS / °C max. range
Switching output:	1 or 2 transistor switching outputs PNP or NPN N/C or N/O
Output load:	max. 1.2 A on version with 1 switching output max. 1 A per output on version with 2 switching outputs
Switching points / Hysteresis:	user-programmable with HYDAC Programming Unit HPG 3000
Response and reset delay:	8 ms to 2000 ms; user-programmable with HYDAC Programming Unit HPG 3000
Long-term drift	$\leq \pm 0.1\%$ FS typ. / year
Ambient conditions	
Compensated temperature range	-25 .. +85 °C
Operating temperature range	-25 .. +85 °C
Storage temperature range	-40 .. +100 °C
Fluid temperature range	-40 .. +100 °C
CE mark	EN 61000-6-1 / 2 / 3 / 4
Vibration resistance to DIN EN 60068-2-6 at 10 .. 500 Hz	$\leq 20$ g
Shock resistance to DIN EN 60068-2-29 (1 ms)	$\leq 100$ g
Protection class to DIN 40050	IP 67 (M12x1, when an IP 67 connector is used)
Other data	
Supply voltage	8 .. 32 V DC
Current consumption	$\leq 25$ mA (inactive switch output)
Residual ripple of supply voltage	$\leq 5\%$
Life expectancy	> 10 million cycles, 0 .. 100 % FS
Weight	approx. 145 g

Note: Reverse polarity protection of the supply voltage, excess voltage, override, short circuit protection are provided.

FS (Full Scale) = relative to the complete measuring range

