



Electronic Temperature Switch ETS 1700

Description:

The electronic temperature switch ETS 1700 is used mainly together with the temperature probe TFP 100, which was specially developed for tank mounting.

The 4-digit display can indicate the actual temperature, one of the switching points or the maximum temperature.

The maximum temperature indicates the highest temperature which has occurred since the unit was switched on or was last reset.

The 4 switching outputs can be used to control heating and cooling processes in hydraulic systems, for example. These 4 switching and switch-back points which are independent of each other can be adjusted very simply via the keypad.

For incorporation into monitoring systems (e.g. with PLC) an analogue output (4 .. 20 mA or 0 .. 10 V) is also available.

Special features:

- 4-digit digital display
- Simple operation with key programming
- 4 limit relays, switching points and switch back points can be adjusted independently
- Analogue output signal selectable (4 .. 20 mA or 0 .. 10 V)
- Many useful additional functions
- Optional mounting position (pressure connection on the top/ bottom, keypad and display can be turned through 180°)

Technical specifications:

Input data	
Measuring range	0 .. +100 °C (+32 .. 212 °F)*
Output data	
Accuracy (display, analogue output)	≤ ± 1.0 °C (≤ ± 2.0 °F)
Repeatability	≤ ± 0.25 % FS
Temperature drift (ambient)	≤ ± 0.03 % FS / °C max. zero point ≤ ± 0.03 % FS / °C max. range
Analogue output (optional)	
Signal	selectable: 4 .. 20 mA ohmic resistance max. 400 Ω 0 .. 10 V ohmic resistance min. 2 kΩ corresponds in each case to 0 .. +100 °C
Switching outputs	
Type	4 relays with change-over contacts in 2 groups (common supply of each group connected)
Switching voltage	0.1 .. 250 V AC / DC
Switching current	0.009 .. 2 A per output
Switching capacity	400 VA, 50 W (for inductive load, use varistors)
Switching cycles	> 20 million at minimum load > 1 million at maximum load
Ambient conditions	
Ambient temperature range	-25 .. +60 °C
Storage temperature range	-40 .. +80 °C
CE mark	EN 61000-6-1 / 2 / 3 / 4
Vibration resistance to DIN EN 60068-2-6 (0 .. 500 Hz)	≤ 5 g
Shock resistance to DIN EN 60068-2-29 (1 ms)	≤ 10 g
Protection class to DIN 40050	IP 65
Other data	
Supply voltage	22 .. 32 V DC
Current consumption	approx. 200 mA
Residual ripple of supply voltage	≤ 10 %
Display	4-digit, LED, 7 segment, red, height of digits 13 mm
Weight	approx. 800 g

Note: Reverse polarity protection of the supply voltage, excess voltage, override, short circuit protection are provided.
* The fluid temperature range of the connected temperature sensor can restrict the display range of the ETS 1700.
FS (Full Scale) = relative to the complete measuring range

Setting options:

The microprocessor integrated into the ETS 1700 enables many useful extra functions in addition to the switching functions, as compared with a normal mechanical temperature switch. It is possible, for example, to activate switching delay times or to change the relay switching direction. All settings are made via the keypad.

Setting ranges of the switching points and switch-back hystereses:

- Switching point relays 1 to 4: 1.5 .. 100 % of the measuring range
- Switch-back point relays 1 to 4: 1 .. 99 % of the measuring range or alternatively
- Switch-back hystereses 1 to 4: 1.. 99 % of the measuring range

Additional functions:

- Switching direction of the relays 1 to 4 (N/C or N/O function)
- Switch-on delay relays 1 to 4 in the range from 0.0 .. 900.0 seconds
- Switch-back delay relays 1 to 4 in the range from 0.0 .. 900.0 seconds
- Switch-back mode (alternatively switch-back point or switch-back hysteresis)
- Display of the actual temperature, a switching point or of the peak value
- Display range individually selectable in °C or °F
- Measurement unit (°C, °F) is displayed
- Analogue output (4 .. 20 mA or 0 .. 10 V)
- Programming disable

Terminal assignment:

Device connection

Pin	
1	+U _B
2	0 V
3	Analogue output Signal +
4	Analogue output Signal - (0 V)
5	Relay 1 N/C
6	Relay 1 N/O
7	Centre relay 1 and 2
8	Relay 2 N/C
9	Relay 2 N/O
10	Relay 3 N/C
11	Relay 3 N/O
12	Centre relay 3 and 4
13	Relay 4 N/C
14	Relay 4 N/O

Probe connection

Pin	
1	+U _B
2	Signal +
3	n.c.
4	Signal -
5	0 V

Model code:

ETS 1 7 0 X - 100 - 000

Type of sensor

0 = For PT 100 sensors

Display

1 = 4-digit display °C
2 = 4-digit display °F

Measuring range

0 .. 100 °C (+32 .. 212 °F)

Modification number

000 = Standard

Note:

On units with a different modification number, please read the label or the technical amendment details supplied with the unit.

Accessories:

PG cable glands, mounting screws, a 5 pole female connector (Binder series 681) for connecting the separate temperature probe and a 3 m sensor cable (LIYCY 4 x 0.25 mm²) are supplied with the unit.

Other accessories, such as vibration mounts etc can be found in the Accessories section.

Separate temperature probe:

(not supplied with the unit)

TFP 100

Sleeve for tank mounting for TFP 100

Part No.: 904696

Part No.: 906170

Dimensions:

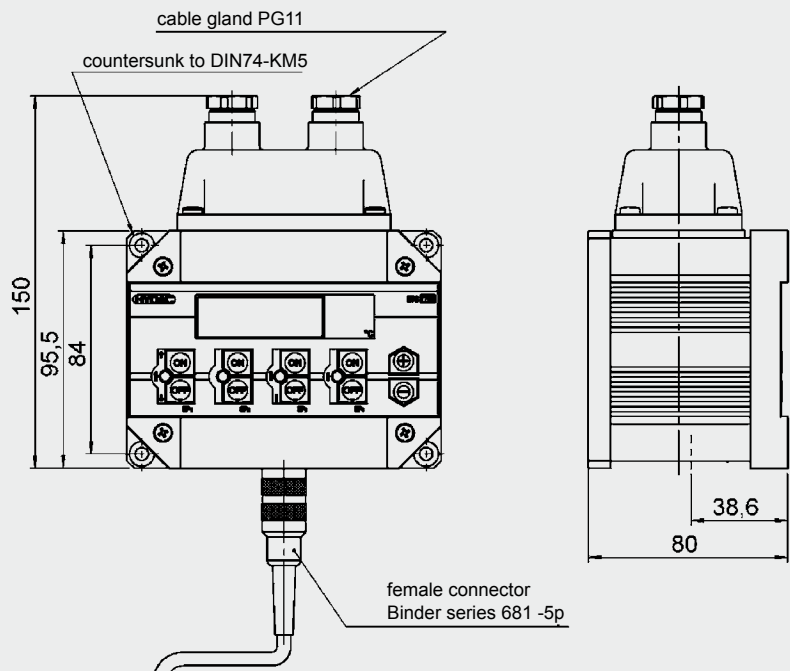

Note:

The information in this brochure relates to the operating conditions and applications described.

For applications or operating conditions not described, please contact the relevant technical department.

Subject to technical modifications.

HYDAC ELECTRONIC GMBH

Hauptstraße 27, D-66128 Saarbrücken

Telephone +49 (0)6897 509-01

Fax +49 (0)6897 509-1726

E-Mail: electronic@hydac.com

Internet: www.hydac.com