



## Electronic Pressure Transmitter HDA 3800 for Steel Works Applications

### Description:

This high-precision pressure transmitter has been specially developed and adapted for the sophisticated measurement demands of steelworks technology.

The unit has a very robust sensor cell with a thin-film strain gauge on a stainless steel membrane. Its outstanding specifications in respect of temperature effect (temperature drift for zero point and range are in each case max.  $\leq \pm 0.01$  % FS / °C) and accuracy ( $\leq \pm 0.15$  % FS typ.) make it ideally suited for use in the ambient conditions found in steelworks. The excellent EMC characteristics guarantee signal stability during the harshest high-frequency, electro-magnetic interference.

### Special features:

- Accuracy  $\leq \pm 0.15$  % FS typ.
- Specially designed for use in steelworks
- Highly robust sensor cell
- Very small temperature error
- Excellent EMC characteristics
- Excellent long term stability

### Technical specifications:

Input data	
Measuring ranges*	16; 60; 100; 150; 250; 300; 350; 400; 500; 600 bar
Overload pressures	32; 120; 200; 500; 800; 900; 900; 900; 900; 1000 bar
Burst pressure	200; 300; 500; 1000; 2000; 2000; 2000; 2000; 2000 bar
Mechanical connection	G1/4 A DIN 3852 G1/2 A DIN 3852
Torque value	20 Nm (G1/4 A) 45 Nm (G1/2 A)
Parts in contact with medium	Mech. connection: Stainless steel Seal: Viton (G1/4 A) NBR O-Ring (G1/2 A)
Output data	
Output signal, permitted resistance	4 .. 20 mA, 2 conductor $R_{Lmax} = (U_B - 10 V) / 20 \text{ mA}$ [kΩ] 0 .. 20 mA, 3 conductor rising $R_{Lmax} = (U_B - 7 V) / 20 \text{ mA}$ [kΩ]
Accuracy to DIN 16086, Max. setting	$\leq \pm 0.15$ % FS typ. $\leq \pm 0.3$ % FS max.
Accuracy at min. setting (B.F.S.L.)	$\leq \pm 0.1$ % FS typ. $\leq \pm 0.15$ % FS max.
Temperature compensation Zero point	$\leq \pm 0.005$ % FS / °C typ. $\leq \pm 0.01$ % FS / °C max.
Temperature compensation Over range	$\leq \pm 0.005$ % FS / °C typ. $\leq \pm 0.01$ % FS / °C max.
Non-linearity at max. setting to DIN 16086	$\leq \pm 0.2$ % FS max. (from 100 bar $\leq \pm 0.15$ % FS max.)
Hysteresis	$\leq \pm 0.1$ % FS max.
Repeatability	$\leq \pm 0.05$ % FS
Rise time	$\leq 1.5$ ms
Long-term drift	$\leq \pm 0.1$ % FS typ. / year
Ambient conditions	
Compensated temperature range	-25 .. +85 °C
Operating temperature range	-40 .. +85 °C
Storage temperature range	-40 .. +100 °C
Fluid temperature range	-40 .. +100 °C
CE mark	EN 61000-6-1 / 2 / 3 / 4
Vibration resistance to DIN EN 60068-2-6 at 10 .. 500 Hz	$\leq 25$ g
Protection class to DIN 40050	IP 68
Other data	
Supply voltage 2 conductor	10 .. 30 V DC
Supply voltage 3 conductor	12 .. 30 V DC
Residual ripple of supply voltage	$\leq 5$ %
Current consumption 3 conductor	approx. 25 mA
Life expectancy	> 10 million cycles, 0 .. 100 % FS
Weight	approx. 210 g

Note: Reverse polarity protection of the supply voltage, excess voltage, override, short circuit protection are provided.

FS (Full Scale) = relative to the complete measuring range

B.F.S.L. = Best Fit Straight Line

\* Other measuring ranges on request

## Model code:

HDA 3 8 X 0 - X - XXX - 124 (XXM)

### Mechanical connection

- 0 = G1/2 A DIN 3852 (male)
- 4 = G1/4 A DIN 3852 (male)

### Electrical connection

- 0 = flying lead (Teflon cable, silicone-free)

### Signal

- A = 4 .. 20 mA, 2 conductor
- E = 0 .. 20 mA, 3 conductor

### Pressure ranges in bar

016; 060; 100; 150; 250; 300; 350; 400; 500; 600

### Modification number

124 = Steelworks

### Cable length in metres

06; 10; 15

### Note:

On units with a different modification number, please read the label or the technical amendment details supplied with the unit.

### Accessories:

Appropriate accessories, such as electrical connectors, can be found in the Accessories section.

## Cable assignment:

Wire	HDA 38X0-A	HDA 38X0-E
black	n.c.	+U <sub>B</sub>
brown	Signal+	Signal
blue	Signal-	0 V
green/ yellow	n.c.	n.c.

## Dimensions:

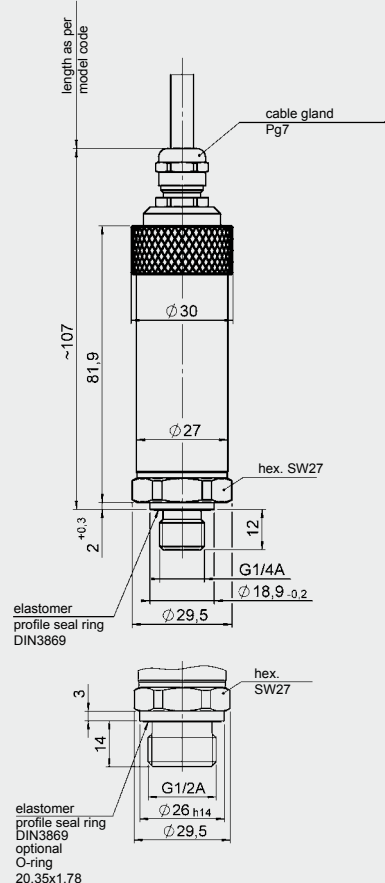

### Note:

The information in this brochure relates to the operating conditions and applications described.

For applications and operating conditions not described, please contact the relevant technical department.

Subject to technical modifications.

### HYDAC ELECTRONIC GMBH

Hauptstraße 27, D-66128 Saarbrücken

Telephone +49 (0)6897 509-01

Fax +49 (0)6897 509-1726

E-Mail: [electronic@hydac.com](mailto:electronic@hydac.com)

Internet: [www.hydac.com](http://www.hydac.com)

