



## Electronic Pressure Transmitter

HDA 4700  
CANopen

### Description:

The HDA 4700 CAN is a digital pressure transmitter which is used to measure relative pressures in hydraulics and pneumatics. The measured pressure value is digitized and made available to the CANopen field bus system via the CANopen protocol. The unit parameters can be viewed and configured by the user via the CANopen object directory using standard CAN software.

This pressure transmitter, which is based on the HDA 4700, has a very accurate and robust sensor cell with a thin-film strain gauge on a stainless steel membrane.

Due to their outstanding temperature and EMC characteristics, together with their compact dimensions, these units can be used in a wide range of applications in the mobile and industrial sectors.

### Special features:

- CANopen interface
- Accuracy  $\leq \pm 0.25\%$  FS typ.
- Robust thin-film cell
- Excellent EMC characteristics
- Very compact design

### Technical specifications:

Input data	
Measuring ranges	40; 100; 250; 400; 600 bar
Overload pressures	80; 200; 500; 800; 1000 bar
Burst pressure	200; 500; 1000; 2000; 2000 bar
Mechanical connection	G1/4 A DIN 3852
Torque value	20 Nm
Parts in contact with medium	Mech. connection: Stainless steel Seal: Viton
Output data	
Output signal	CANopen protocol
Accuracy to DIN 16086, Max. setting	$\leq \pm 0.25\%$ FS typ. $\leq \pm 0.5\%$ FS max.
Accuracy at min. setting (B.F.S.L.)	$\leq \pm 0.15\%$ FS typ. $\leq \pm 0.25\%$ FS max.
Temperature compensation Zero point	$\leq \pm 0.008\%$ FS / °C typ. $\leq \pm 0.015\%$ FS / °C max.
Temperature compensation Over range	$\leq \pm 0.008\%$ FS / °C typ. $\leq \pm 0.015\%$ FS / °C max.
Non-linearity at max. setting to DIN 16086	$\leq \pm 0.3\%$ FS max.
Hysteresis	$\leq \pm 0.1\%$ FS max.
Repeatability	$\leq \pm 0.08\%$ FS
Rise time	$\leq 1$ ms
Long-term drift	$\leq \pm 0.1\%$ FS typ. / year
Ambient conditions	
Compensated temperature range	-25 .. +85 °C
Operating temperature range	-40 .. +85 °C *
Storage temperature range	-40 .. +100 °C
Fluid temperature range	-40 .. +100 °C *
CE mark	EN 61000-6-1 / 2 / 3 / 4
Vibration resistance to DIN EN 60068-2-6 at 10 .. 500 Hz	$\leq 20$ g
Protection class to DIN 40050	IP 67
Other data	
Supply voltage	10 .. 35 V DC
Residual ripple of supply voltage	$\leq 5\%$
Current consumption 3 conductor	approx. 25 mA
Life expectancy	> 10 million cycles 0 .. 100 % FS
Weight	approx. 150 g

Note: Reverse polarity protection of the supply voltage, excess voltage, override, short circuit protection are provided.  
**FS (Full Scale)** = relative to the complete measuring range  
**B.F.S.L.** = Best Fit Straight Line  
 Other models on request.

## Model code:

HDA 4 7 4 8 - K - XXXX - 000

### Mechanical connection

4 = G1/4 A DIN 3852 (male)

### Electrical connection

8 = M12x1, 5 pole  
(connector not supplied)

### Signal

K = CANopen

### Pressure ranges in bar

0040; 0100; 0250; 0400; 0600

### Modification number

000 = Standard (Baud Rate: 250k Node Id: 1)

### Note:

On units with a different modification number, please read the label or the technical amendment details supplied with the unit.

### Accessories:

Appropriate accessories, such as electrical connectors, can be found in the Accessories section.

## Protocol data for CANopen:

Communication profile	DS301 V4.02
Device profile	DS404 V1.2
Baud rates	10 kbit .. 1 Mbit corresp. to DS305 V1.1
Transmission services	
- PDO	measured value as 16/32 bit, status
- Transfer	synchronous, asynchronous, cyclical, measured value change, exceeding boundaries
Node ID/Baudrate	Can be set via Manufacturer Specific Profile

## Dimensions:

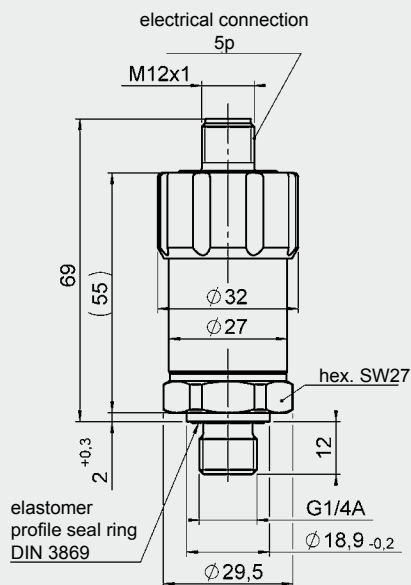

## Pin connections:

M12x1

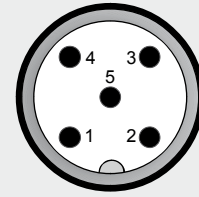

Pin	Signal	Description
1	PE	shield/housing
2	+U <sub>B</sub>	supply +
3	0 V	supply -
4	CAN_H	bus line dominant high
5	CAN_L	bus line dominant low

### Note:

The information in this brochure relates to the operating conditions and applications described.

For applications and operating conditions not described, please contact the relevant technical department.

Subject to technical modifications.

### HYDAC ELECTRONIC GMBH

Hauptstraße 27, D-66128 Saarbrücken

Telephone +49 (0)6897 509-01

Fax +49 (0)6897 509-1726

E-Mail: [electronic@hydac.com](mailto:electronic@hydac.com)

Internet: [www.hydac.com](http://www.hydac.com)