

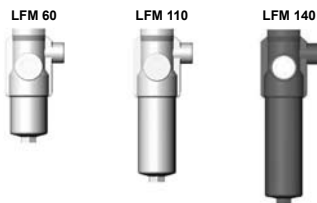

## Inline Filter LFM with Differential Pressure Relief Valve up to 120 l/min, up to 63 bar



### 1. TECHNICAL SPECIFICATIONS

#### 1.1 FILTER HOUSING

##### Construction

The filter housings are designed in accordance with international regulations. They consist of a filter head with screw-in filter bowl.

Standard equipment:

- With differential pressure controlled relief valve
- Port for clogging indicator in filter head

#### 1.2 FILTER ELEMENTS

HYDAC filter elements are validated and their quality is constantly monitored according to the following standards:

- ISO 2941
- ISO 2942
- ISO 2943
- ISO 3724
- ISO 3968
- ISO 11170
- ISO 16889

##### Contamination retention capacities in g

LFM	Betamicon® BN4HC			
	3 µm	5 µm	10 µm	20 µm
60	6.5	7.3	7.8	8.0
110	13.8	15.5	16.4	16.9
140	18.1	20.3	21.5	22.2

Filter elements are available with the following pressure stability values:

Betamicon® (BN4HC): 20 bar

#### 1.3 FILTER SPECIFICATIONS

Nominal pressure	63 bar
Fatigue strength	at nominal pressure 10 <sup>6</sup> load cycles from 0 to nominal pressure
Temperature range	-30 °C to +100 °C (LFM 140: -30 °C to -10 °C: p <sub>max</sub> =31.5 bar)
Material of filter head	aluminium
Material of filter bowl	aluminium (steel on LFM 140)
Type of clogging indicator	VM (differential pressure indicator up to 210 bar operating pressure)
Pressure setting of clogging indicator	2 bar (others on request)
Cracking pressure of diff. pressure relief valve	3.5 bar (others on request)

#### 1.4 SEALS

NBR (= Perbunan)

#### 1.5 MOUNTING

As inline filter

#### 1.6 SPECIAL MODELS AND ACCESSORIES

- Pressure release / oil drain plug (SO184)

#### 1.7 SPARE PARTS

See Original Spare Parts List

#### 1.8 CERTIFICATES AND APPROVALS

On request

#### 1.9 COMPATIBILITY WITH HYDRAULIC FLUIDS TO ISO 2943

- Hydraulic oils H to HLPD DIN 51524
- Lubrication oils DIN 51517, API, ACEA, DIN 51515, ISO 6743
- Compressor oils DIN 51506
- Biodegradable operating fluids VDMA 24568 HETG, HEES, HEPG
- Non-flam operating fluids HFA, HFB, HFC and HFD
- Operating fluids with high water content (>50% water content) on request

#### 1.10 IMPORTANT INFORMATION

- Filter housing must be earthed
- When using electrical clogging indicators, the electrical power supply to the system must be switched off before removing the clogging indicator connector.

#### Symbol for hydraulic systems

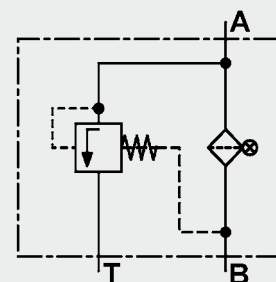

## 2. MODEL CODE (also order example)

**LFM BN/HC 110 F C 10 D 1 . X /-L24**

### 2.1 COMPLETE FILTER

**Filter type** \_\_\_\_\_

LFM

**Filter material of element** \_\_\_\_\_

BN/HC Betamicon® (BN4HC)

**Size of filter or element** \_\_\_\_\_

LFM: 60, 110, 140

**Operating pressure** \_\_\_\_\_

F = 63 bar

**Type and size of port** \_\_\_\_\_

Type	Port	Filter size		
		60	110	140
C	G 3/4	●	●	●

**Filtration rating in µm** \_\_\_\_\_

BN4HC: 3, 5, 10, 20

**Type of clogging indicator** \_\_\_\_\_

Y with plastic blanking plug in indicator port

A with steel blanking plug in indicator port

B visual

C electrical

D visual and electrical

for other clogging indicators  
see brochure no. 7.050../..

**Type code** \_\_\_\_\_

1

**Modification number** \_\_\_\_\_

X the latest version is always supplied

**Supplementary details** \_\_\_\_\_

DBV5.5 cracking pressure of pressure relief valve 5.5 bar

L... light with appropriate voltage (24V, 48V, 110V, 220V)

LED 2 light emitting diodes up to 24 Volt

SO 184 pressure release / oil drain plug

V FPM seals

] only for clogging indicators  
type D

### 2.2 REPLACEMENT ELEMENT

**0110 D 010 BN4HC /-V**

**Size** \_\_\_\_\_

0060, 0110, 0140

**Type** \_\_\_\_\_

D

**Filtration rating in µm** \_\_\_\_\_

BN4HC: 003, 005, 010, 020

**Filter material** \_\_\_\_\_

BN4HC

**Supplementary details** \_\_\_\_\_

V (for descriptions, see point 2.1)

### 2.3 REPLACEMENT CLOGGING INDICATOR

**VM 2 D . X /-L24**

**Type** \_\_\_\_\_

VM differential pressure indicator up to 210 bar operating pressure

**Pressure setting** \_\_\_\_\_

2 standard 2 bar, others on request

**Type of clogging indicator** \_\_\_\_\_

D (see point 2.1)

**Modification number** \_\_\_\_\_

X the latest version is always supplied

**Supplementary details** \_\_\_\_\_

L..., LED, V (for descriptions, see point 2.1)

### 3. FILTER CALCULATION / SIZING

The total pressure drop of a filter at a certain flow rate Q is the sum of the housing  $\Delta p$  and element  $\Delta p$  and is calculated as follows:

$$\Delta p_{\text{total}} = \Delta p_{\text{housing}} + \Delta p_{\text{element}}$$

$$\Delta p_{\text{housing}} = (\text{see point 3.1})$$

$$\Delta p_{\text{Element}} = Q \cdot \frac{SK^*}{1000} \cdot \frac{\text{viscosity}}{30}$$

(\*see point 3.2)

For ease of calculation, our Filter Sizing Program is available on request free of charge.

**NEW:** Sizing online at [www.hydac.com](http://www.hydac.com)

#### 3.1 $\Delta P$ -Q HOUSING GRAPHS BASED ON ISO 3968

The housing graphs apply to mineral oil with a density of 0.86 kg/dm<sup>3</sup> and a kinematic viscosity of 30 mm<sup>2</sup>/s.

In this case, the differential pressure changes proportionally to the density.

##### LFM 60/110/140

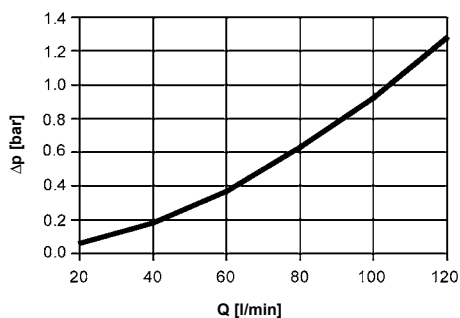

### 3.2 GRADIENT COEFFICIENTS (SK) FOR FILTER ELEMENTS

The gradient coefficients in mbar/(l/min) apply to mineral oils with a kinematic viscosity of 30 mm<sup>2</sup>/s. The pressure drop changes proportionally to the change in viscosity.

LFM	BN4HC			
	3 μm	5 μm	10 μm	20 μm
60	28.9	20.4	13.2	7.9
110	14.9	10.7	6.6	3.7
140	12.8	8.2	4.8	2.9

#### BN4HC: LFM 60

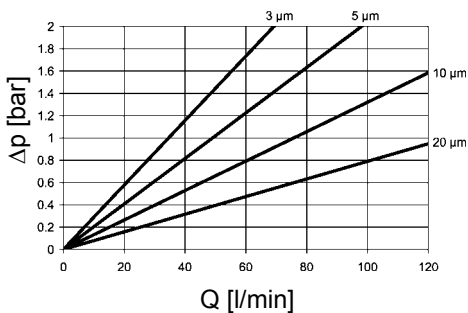

#### BN4HC: LFM 140

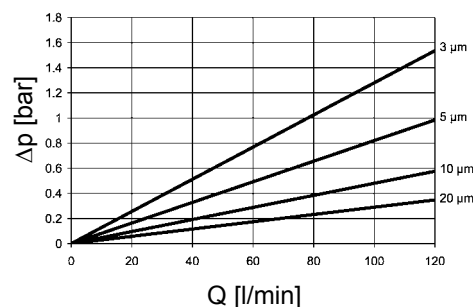

#### BN4HC: LFM 110

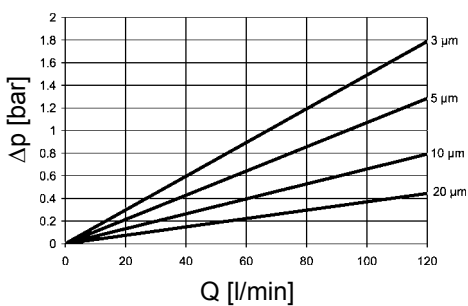

## 4. DIMENSIONS

outlet  
G 3/4 x 16  
deep

inlet  
G 3/4 x 16 deep

LFM 60 = 206.5  
LFM 110 = 274.5  
LFM 140 = 318.0

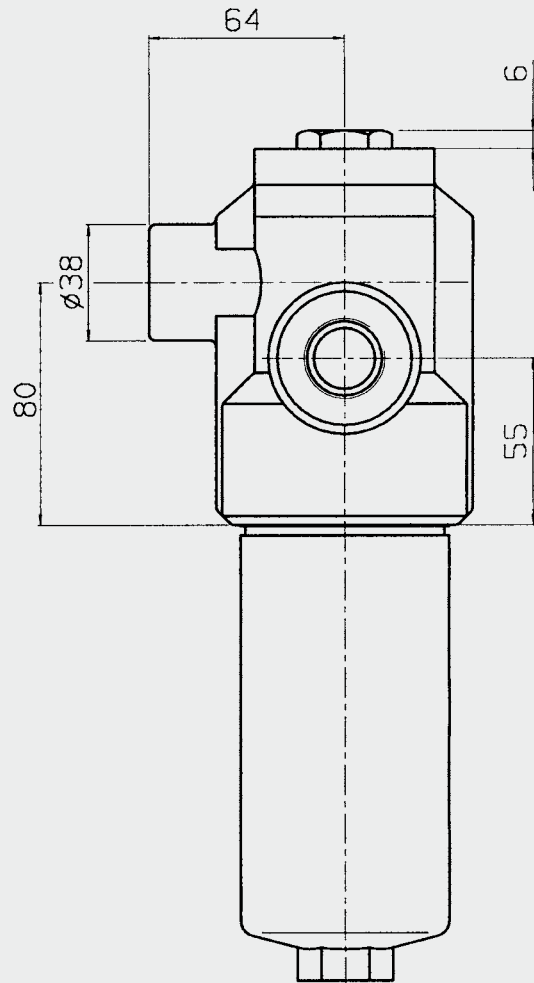
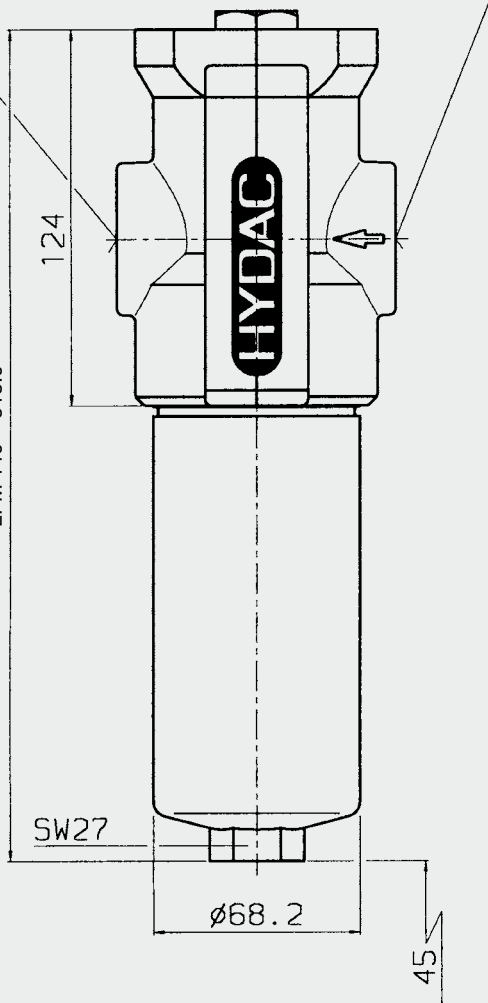

M6 x 9 deep

tank connection  
M18 x 1.5 x 12 deep

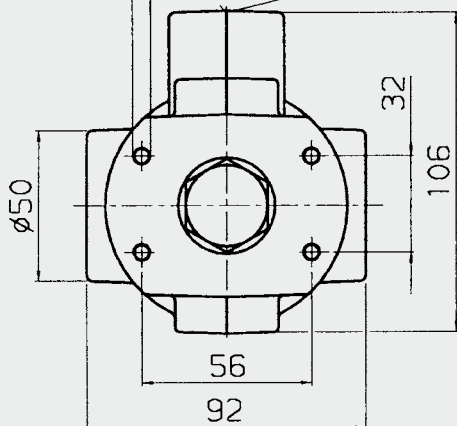

LFM	Weight incl. Element [kg]	Vol. of pressure chamber [l]
60	1.9	0.20
110	2.3	0.33
140	4.5	0.40

### NOTE

The information in this brochure relates to the operating conditions and applications described.

For applications or operating conditions not described, please contact the relevant technical department.

Subject to technical modifications.

**HYDAC** Filbertechnik GmbH  
Industriegebiet  
D-66280 Sulzbach/Saar  
Tel.: 0 68 97 / 509-01  
Fax: 0 68 97 / 509-300  
Internet: www.hydac.com  
E-Mail: filter@hydac.com