



Inline Filter LPF...D A Manifold Mounted, Rear Flanged

up to 160 l/min, up to 25 bar



1. TECHNICAL SPECIFICATIONS

1.1 FILTER HOUSING

Construction

The filter housings are designed in accordance with international regulations. They consist of a filter head and a screw-in filter bowl.

Standard equipment:

- with bypass valve
- connection for a clogging indicator

1.2 FILTER ELEMENTS

HYDAC filter elements are validated and their quality is constantly monitored according to the following standards:

- ISO 2941
- ISO 2942
- ISO 2943
- ISO 3724
- ISO 3968
- ISO 11170
- ISO 16889

Contamination retention capacities in g Betamicon® (BN4HC)

LPF...D A	3 µm	5 µm	10 µm	20 µm
160	19.8	22.2	23.5	24.3

Filter elements are available with the following pressure stability values:

Betamicon® (BN4HC):	20 bar
Wire mesh (W/HC):	20 bar

1.3 FILTER SPECIFICATIONS

Nominal pressure	25 bar
Fatigue strength	at nominal pressure 10 ⁶ load cycles from 0 to nominal pressure
Temperature range	-30 °C to +100 °C
Material of filter head	aluminium
Material of filter bowl	aluminium
Type of clogging indicator	VM (differential pressure indicator up to 210 bar operating pressure)
Pressure setting of clogging indicator	5 bar (others on request)
Cracking pressure of bypass valve	3.5 bar (others on request)

1.4 SEALS

NBR (= Perbunan)

1.5 MOUNTING

As inline filter

1.6 SPECIAL MODELS AND ACCESSORIES

- without bypass valve
- without port for clogging indicator
- with bowl locking clip

1.7 SPARE PARTS

See Original Spare Parts List

1.8 CERTIFICATES AND APPROVALS

On request

1.9 COMPATIBILITY WITH HYDRAULIC FLUIDS ISO 2943

- Hydraulic oils H to HLPD DIN 51524
- Lubrication oils DIN 51517, API, ACEA, DIN 51515, ISO 6743
- Compressor oils DIN 51506
- Biodegradable operating fluids VDMA 24568 HETG, HEES, HEPG
- Non-flam operating fluids HFA, HFB, HFC and HFD
- Operating fluids with high water content (>50% water content) on request

Symbol for hydraulic systems

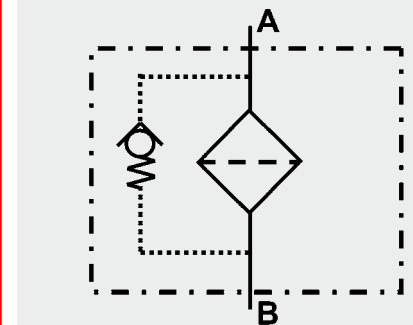

2. MODEL CODE (also order example)

LPF BN/HC 160 D A 10 D 1 . X /-L24

2.1 COMPLETE FILTER

Filter type _____

LPF

Filter material of element _____

BN/HC Betamicron® (BN4HC)

W/HC Stainless steel wire mesh

Size of filter or element _____

LPF..DA: 160 (Sizes 240 and 280 on request!)

Operating pressure _____

D = 25 bar

Type and size of port _____

A 2 mounting bores

Filtration rating in µm _____

BN4HC : 3, 5, 10, 20

W/HC : 25, 50, 100, 200

Type of clogging indicator _____

W without port for clogging indicator

Y plastic blanking plug in indicator port

A with steel blanking plug in indicator port

B visual indicator

C electrical indicator

D visual and electrical indicator

for other clogging indicators,
see brochure no. E 7.050.../...

Type code _____

1

Modification number _____

X the latest version is always supplied

Supplementary details _____

B. cracking pressure of bypass valve (e. g.: B3.5 = 3.5 bar); no details = without bypass valve

GS bowl locking clip

L... light with appropriate voltage (24, 48, 110, 220 Volt)

] only for clogging indicators

LED 2 light emitting diodes up to 24 Volt

] type "D"

V FPM seals

W suitable for HFA and HFC emulsions

2.2 REPLACEMENT ELEMENT

0160 D 010 BN4HC /-V

Size _____

0160

Type _____

D

Filtration rating in µm _____

BN4HC : 003, 005, 010, 020

W/HC : 025, 050, 100, 200

Filter material _____

BN4HC, W/HC

Supplementary details _____

V (for descriptions, see point 2.1)

2.3 REPLACEMENT CLOGGING INDICATOR

VM 5 D . X /-L24

Type _____

VM differential pressure indicator up to 210 bar operating pressure

Pressure setting _____

5 standard 5 bar, others on request

Type of clogging indicator _____

D (see point 2.1)

Modification number _____

X the latest version is always supplied

Supplementary details _____

L..., LED, V, W (for descriptions, see point 2.1)

3. FILTER CALCULATION / SIZING

The total pressure drop of a filter at a certain flow rate Q is the sum of the housing Δp and element Δp and is calculated as follows:

$$\Delta p_{\text{total}} = \Delta p_{\text{housing}} + \Delta p_{\text{element}}$$

$$\Delta p_{\text{housing}} = (\text{see point 3.1})$$

$$\Delta p_{\text{Element}} = Q \cdot \frac{SK^*}{1000} \cdot \frac{\text{viscosity}}{30}$$

(*see point 3.2)

For ease of calculation, our Filter Sizing Program is available on request free of charge.

NEW: Sizing online at www.hydac.com

3.1 ΔP -Q HOUSING GRAPHS BASED ON ISO 3968

The housing graphs apply to mineral oil with a density of 0.86 kg/dm³ and a kinematic viscosity of 30 mm²/s. In this case, the differential pressure changes proportionally to the density.

LPF 160

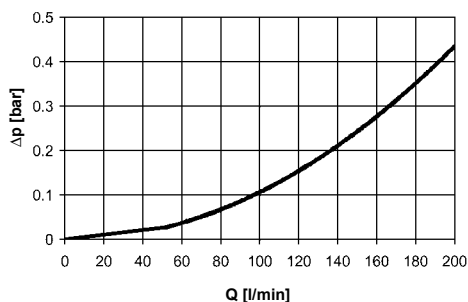

3.2 GRADIENT COEFFICIENTS (SK) FOR FILTER ELEMENTS

The gradient coefficients in mbar/(l/min) apply to mineral oils with a kinematic viscosity of 30 mm²/s. The pressure drop changes proportionally to the change in viscosity.

LPF...	BN4HC				W/HC
	3 μm	5 μm	10 μm	20 μm	
160	13.1	8.8	4.6	3.5	0.28

BN4HC: LPF 160

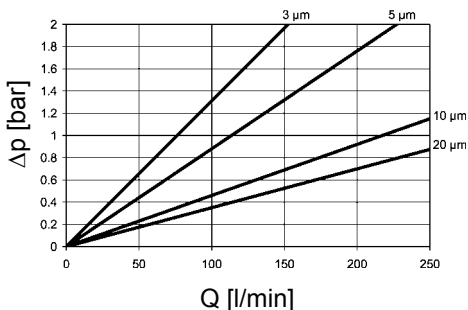

4. DIMENSIONS

LPF 160...D A (SHOWN WITH BOWL LOCKING CLIP)

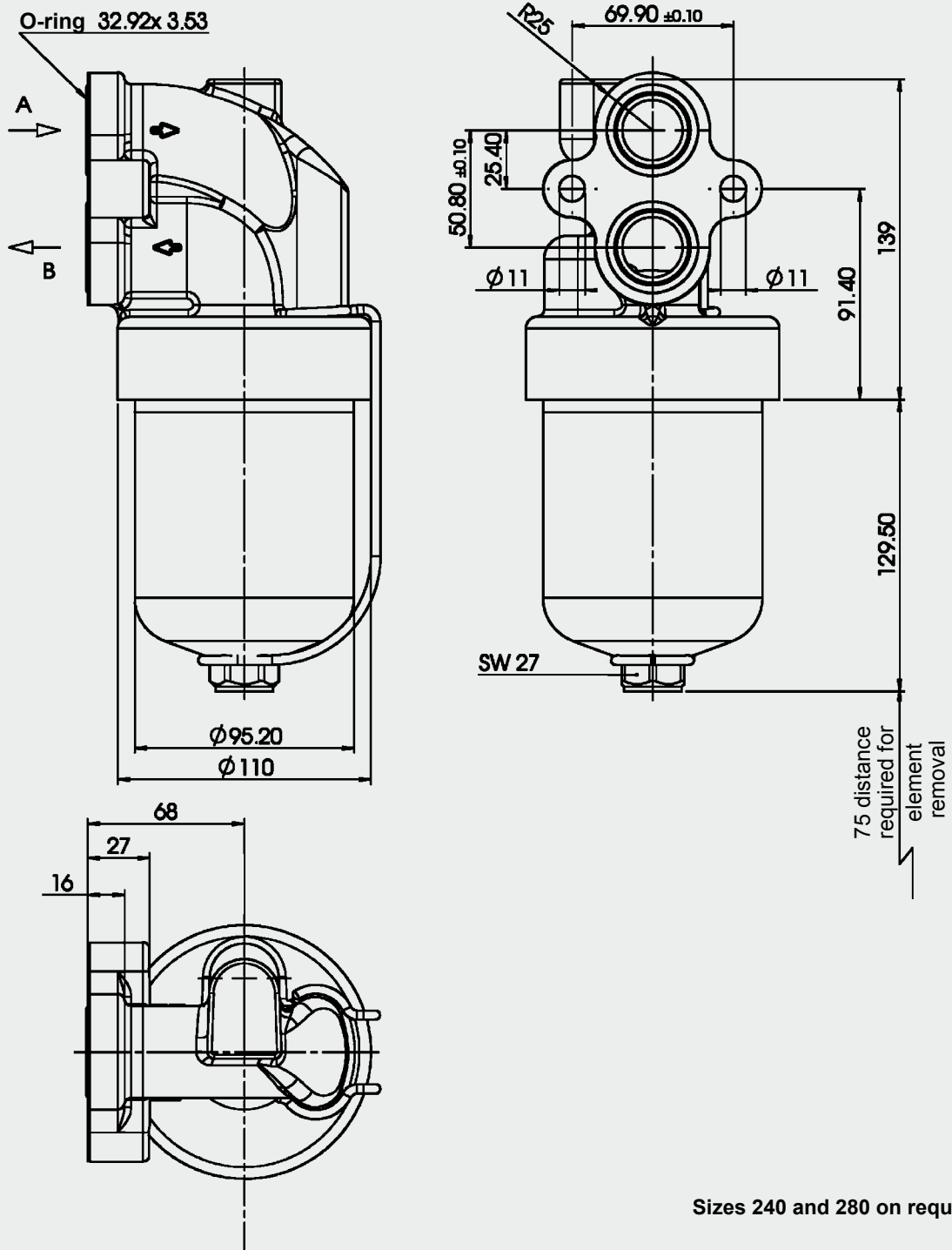

Sizes 240 and 280 on request!

LPF... D A	Weight incl. element [kg]	Volume of pressure chamber [l]
160	2.30	0.60

NOTE

The information in this brochure relates to the operating conditions and applications described.

For applications or operating conditions not described, please contact the relevant technical department.

Subject to technical modifications.

HYDAC Filtertechnik GmbH
 Industriegebiet
D-66280 Sulzbach/Saar
 Tel.: 0 68 97 / 509-01
 Fax: 0 68 97 / 509-300
 Internet: www.hydac.com
 E-Mail: filter@hydac.com