



Spin-On Filter MF/MFD up to 300 l/min, up to 8 bar



1. TECHNICAL SPECIFICATIONS

1.1 FILTER HOUSING

Construction

The filter consists of a filter head with built-in bypass valve and a screw-on filter cartridge.

Standard equipment:

- with 1.7 bar bypass valve

1.2 FILTER CARTRIDGES

MG: Cartridge connection thread to ISO 228

Sealing on inside
(note: the seal on the 0080 MA cartridge is also on the inside!)

MA: Cartridge connection UN thread
Sealing on the outside

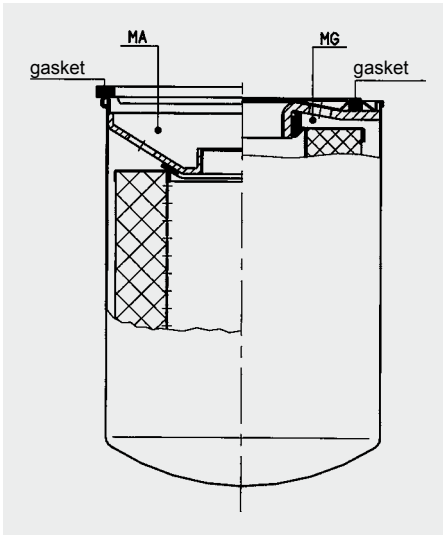

1.3 FILTER SPECIFICATIONS

Nominal pressure	8 bar
Temperature range	-30 °C to +100 °C
Pressure setting of clogging indicator: Δp_a	Type E: 0 to 16 bar Type F: 1.5 or 2 bar Type UE: 0 to -1.0 bar Type UF: -0.2 bar
Type of clogging indicator	VMF (return line pressure indicator)
Material of filter head	Aluminium
Material of filter cartridge	Sheet steel
Cracking pressure of bypass valve	1.7 bar (standard)

1.4 SEALS

NBR (= Perbunan)

1.5 MOUNTING

As inline filter

1.6 SPECIAL MODELS AND ACCESSORIES

without bypass valve or with other bypass cracking pressures

1.7 SPARE PARTS

See Original Spare Parts List

1.8 CERTIFICATES AND APPROVALS

On request

1.9 COMPATIBILITY WITH HYDRAULIC FLUIDS ISO 2943

- Hydraulic oils H to HLPD DIN 51524
- Lubrication oils DIN 51517, API, ACEA, DIN 51515, ISO 6743
- Compressor oils DIN 51506
- Biodegradable operating fluids VDMA 24568 HETG, HEES, HEPG
- Non-flam operating fluids HFA, HFB, HFC and HFD
- Operating fluids with high water content (>50% water content) on request

Symbol for hydraulic systems

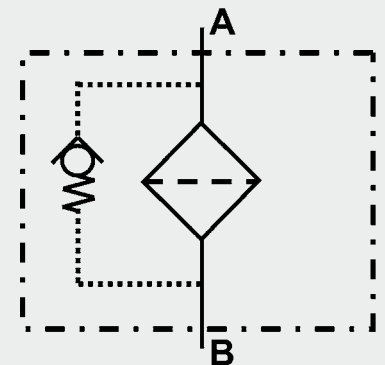

2. MODEL CODE (ALSO ORDER EXAMPLE)

MF BN 160 A U E 10 F 1 .X /-KB

2.1 COMPLETE FILTER

Filter type

MF (all sizes; 1 filter cartridge)
MFD (size 160 and 180; 2 filter cartridges)

Filter material of element

BN Betamicron®
P Paper (only MF 80 and MF/MFD 160)

Size of filter or cartridge

MF: 80, 160, 180
MFD: 160, 180

Operating pressure

A 8 bar

Type of cartridge connection

G thread to ISO 228 (G1¼)
U UN thread (1-12 UNF, 1½ x 16 UN-2B)

Type and size of port

Type	Port	Filter size		
		80	160	180
C	G ¾	MF	–	–
E	G1 ¼	–	MF	MF
F	G1 ½	–	MFD	MFD

Filtration rate in µm

BN 3, 5, 10, 20
P 10

Type of clogging indicator

A steel blanking plug in indicator port] pressure indicators] for other clogging indicators see brochure no. E 7.050../..
E pressure gauge		
F pressure switch] vacuum indicators	
UE vacuum gauge		
UF vacuum switch		

Type code

0
1 - 8 see point 2.4

Modification number

X the latest version is always supplied

Supplementary details

B. bypass cracking pressure (e.g.: B0.2 = 0.2 bar; B0.25 = 0.25 bar; B2 = 2 bar)
KB without bypass valve

2.2 REPLACEMENT CARTRIDGE

0160 MA 010 BN

Size

0080, 0160, 0180

Type

MG for filters with cartridge connection G (= thread to ISO 228);
paper filter material only (exception: MF 80: 20 BN)
MA for filters with cartridge connection U (= UN thread)

Filtration rate in µm

BN 003, 005, 010, 020 (for MF 80: MA = all filtration ratings; MG = 20 µm)
P 010

Filter material

BN, P

2.3 REPLACEMENT CLOGGING INDICATOR

VMF 2 F .X

Type

VMF return line pressure indicator

Pressure setting

2 (see point 1.3)

Type of clogging indicator

F (see point 2.1)

Modification number

X the latest version is always supplied

2.4 MOUNTING POSITION OF THE CLOGGING INDICATOR

MF 80

MF 160/180

MFD 160/180

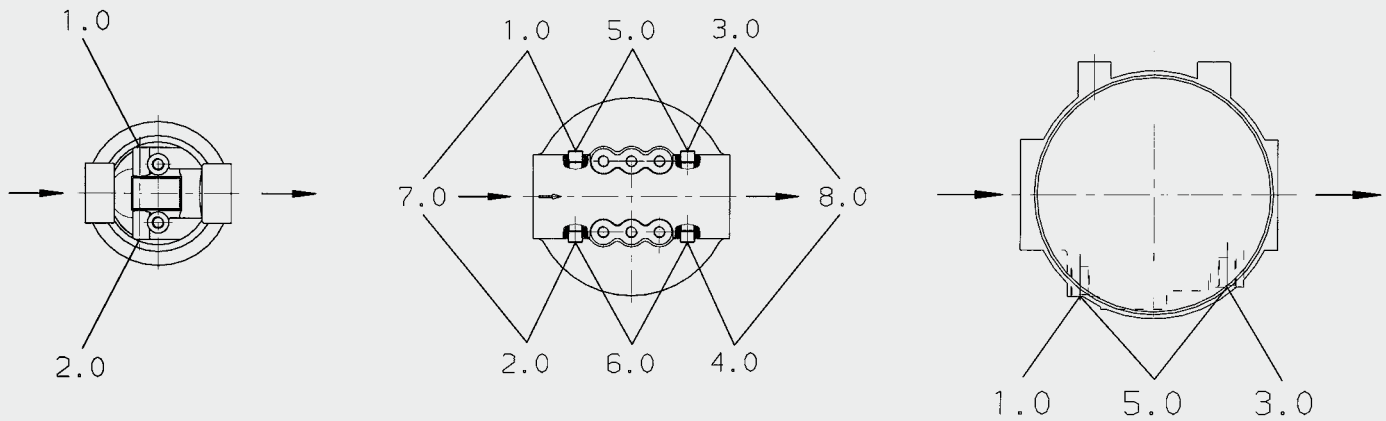

For MF filters

Type code	Mounting position of the clogging indicator	Application of complete filter	Type of indicator	Specials
0.X	Without clogging indicator, blanking plug in all indicator ports			–
1.X	Filter inlet: on left	Return line filter	Pressure indicator	–
2.X	Filter inlet: on right	Return line filter	Pressure indicator	–
3.X	Filter outlet: on left	Suction filter	Vacuum indicator	Only for sizes 160 and 180, on versions: - with bypass cracking pressure 0.2 bar (.../B0.2) - without bypass valve (.../KB)
4.X	Filter outlet: on right	Suction filter	Vacuum indicator	Only for sizes 160 and 180, on versions: - with bypass cracking pressure 0.2 bar (.../B0.2) - without bypass valve (.../KB)
5.X	Filter inlet & outlet: on left	Pressure filter	Pressure and vacuum indicator	–
6.X	Filter inlet & outlet: on right	Pressure filter	Pressure and vacuum indicator	–
7.X	Filter inlet: on right & left	Return line filter	Pressure indicator	–
8.X	Filter outlet: on right & left	Suction filter	Vacuum indicator	Only for sizes 160 and 180, on versions: - with bypass cracking pressure 0.2 bar (.../B0.2) - without bypass valve (.../KB)

For MFD filters

Type code	Mounting position of the clogging indicator	Application of complete filter	Type of indicator	Specials
0.X	Without clogging indicator, blanking plug in all indicator ports			–
1.X	Filter inlet: on right	Return line filter	Pressure indicator	–
3.X	Filter outlet: on right	Suction filter	Vacuum indicator	Only on versions: - with bypass cracking pressure 0.2 bar (.../B0.2) - without bypass valve (.../KB)
5.X	Filter inlet & outlet: on right	Pressure filter	Pressure & vacuum indicator	

2.5 CARTRIDGE SELECTION TABLE

Filter type MF

Size 80	Cartridge
MF P 80 AGC 10 ...	0080 MG 010 P
MF BN 80 AUC 10 ...	0080 MA 010 BN
MF BN 80 AGC 20 ...	0080 MG 020 BN

Size 160	Cartridge
MF P 160 AGE 10...	0160 MG 010 P
MF BN 160 AUE 3...	0160 MA 003 BN
MF BN 160 AUE 5...	0160 MA 005 BN
MF BN 160 AUE 10...	0160 MA 010 BN
MF BN 160 AUE 20...	0160 MA 020 BN

Size 180	Cartridge
MF BN 180 AUE 3...	0180 MA 003 BN
MF BN 180 AUE 5...	0180 MA 005 BN
MF BN 180 AUE 10...	0180 MA 010 BN
MF BN 180 AUE 20...	0180 MA 020 BN

Filter type MFD

Size 80	Cartridge
–	not available
–	not available
–	not available

Size 160	Cartridge
MFD P 160 AGF 10...	0160 MG 010 P
MFD BN 160 AUF 3...	0160 MA 003 BN
MFD BN 160 AUF 5...	0160 MA 005 BN
MFD BN 160 AUF 10...	0160 MA 010 BN
MFD BN 160 AUF 20...	0160 MA 020 BN

Size 180	Cartridge
MFD BN 180 AUF 3...	0180 MA 003 BN
MFD BN 180 AUF 5...	0180 MA 005 BN
MFD BN 180 AUF 10...	0180 MA 010 BN
MFD BN 180 AUF 20...	0180 MA 020 BN

2.6 CHANGING THE CARTRIDGE

Filter cartridge type MG:

Unscrew filter cartridge (using a strap wrench, if necessary). Lubricate seal on the new cartridge. Screw in new cartridge until contact is made with the sealing surface. Then hand-tighten. Check for leakage and tighten further if necessary.

Filter cartridge type MA:

Unscrew filter cartridge (using a strap wrench, if necessary). Lubricate new seal and insert it into the filter head. Screw in new cartridge until contact is made with the sealing surface. Then hand-tighten. Check for leakage and tighten further if necessary.

3. FILTER CALCULATION / SIZING

The total pressure drop of a filter at a certain flow rate Q is the sum of the housing Δp and element Δp and is calculated as follows:

$$\Delta p_{\text{total}} = \Delta p_{\text{housing}} + \Delta p_{\text{element}}$$

$$\Delta p_{\text{housing}} = (\text{see point 3.1})$$

$$\Delta p_{\text{element}} = Q \cdot \frac{SK^*}{1000} \cdot \frac{\text{viscosity}}{30}$$

(*see point 3.2)

For ease of calculation, our Filter Sizing Program is available on request free of charge.

NEW: Sizing online at www.hydac.com

3.1 Δp -Q HOUSING GRAPHS BASED ON ISO 3968

The housing graphs apply to mineral oil with a density of 0.86 kg/dm³ and a kinematic viscosity of 30 mm²/s. In this case, the differential pressure changes proportionally to the density.

MF 80

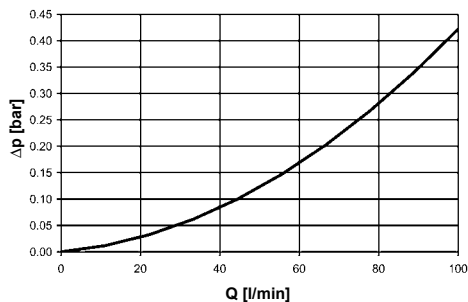

MF 160, 180

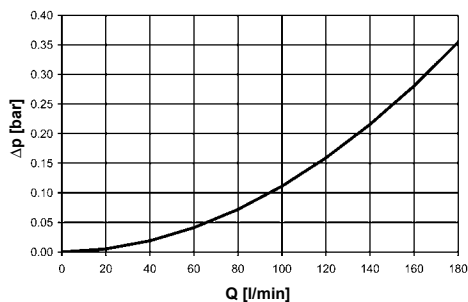

MFD 160, 180

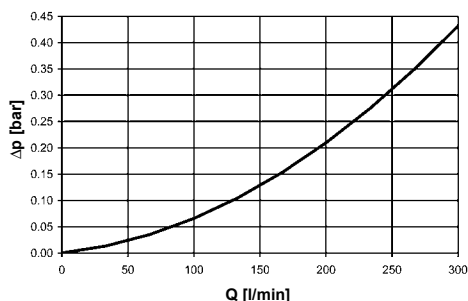

3.2 GRADIENT COEFFICIENTS (SK) FOR FILTER ELEMENTS

The gradient coefficients in mbar/(l/min) apply to mineral oils with a kinematic viscosity of 30 mm²/s. The pressure drop changes proportionally to the change in viscosity.

BN	Filtration rating			
	3 μm	5 μm	10 μm	20 μm
80	9.5	8.1	4.3	2.5
160	4.3	3.6	2.0	1.1
180	2.2	1.9	1.1	0.6

3.3 CALCULATION CRITERIA

Filters should be calculated on the basis of a total differential pressure with clean element and at operating temperature; for use as:

Suction filter: 0.03 - 0.05 bar

Return line filter: 0.3 - 0.5 bar

Pressure filter: 0.3 - 0.5 bar

However, cold start conditions must be taken into account!

4. DIMENSIONS

MF 80

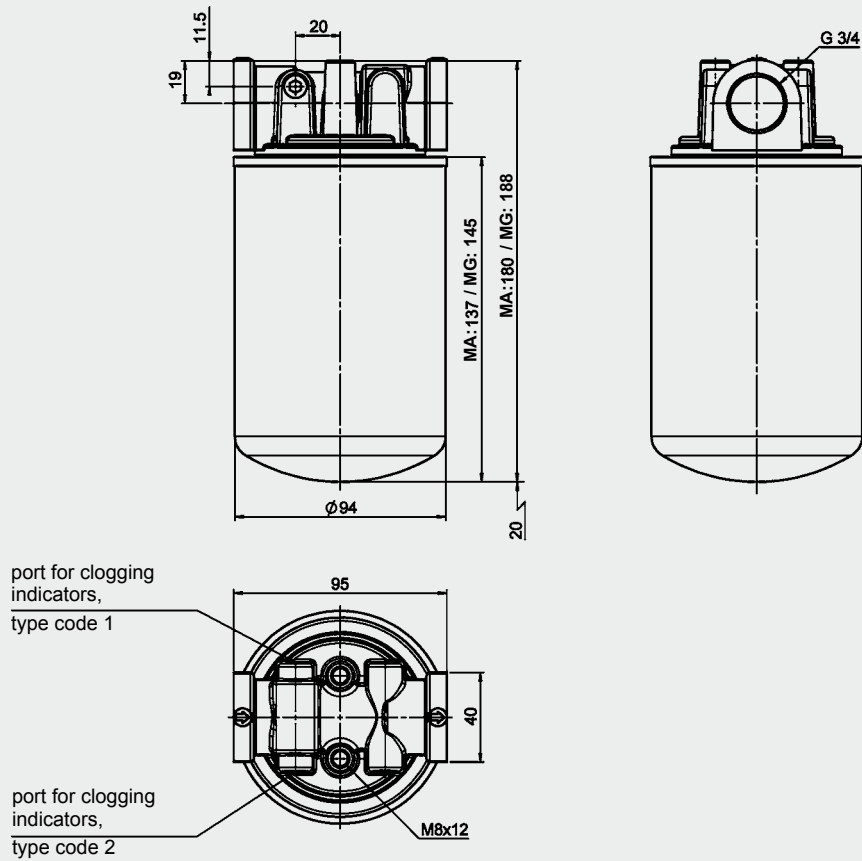

MF 160/180

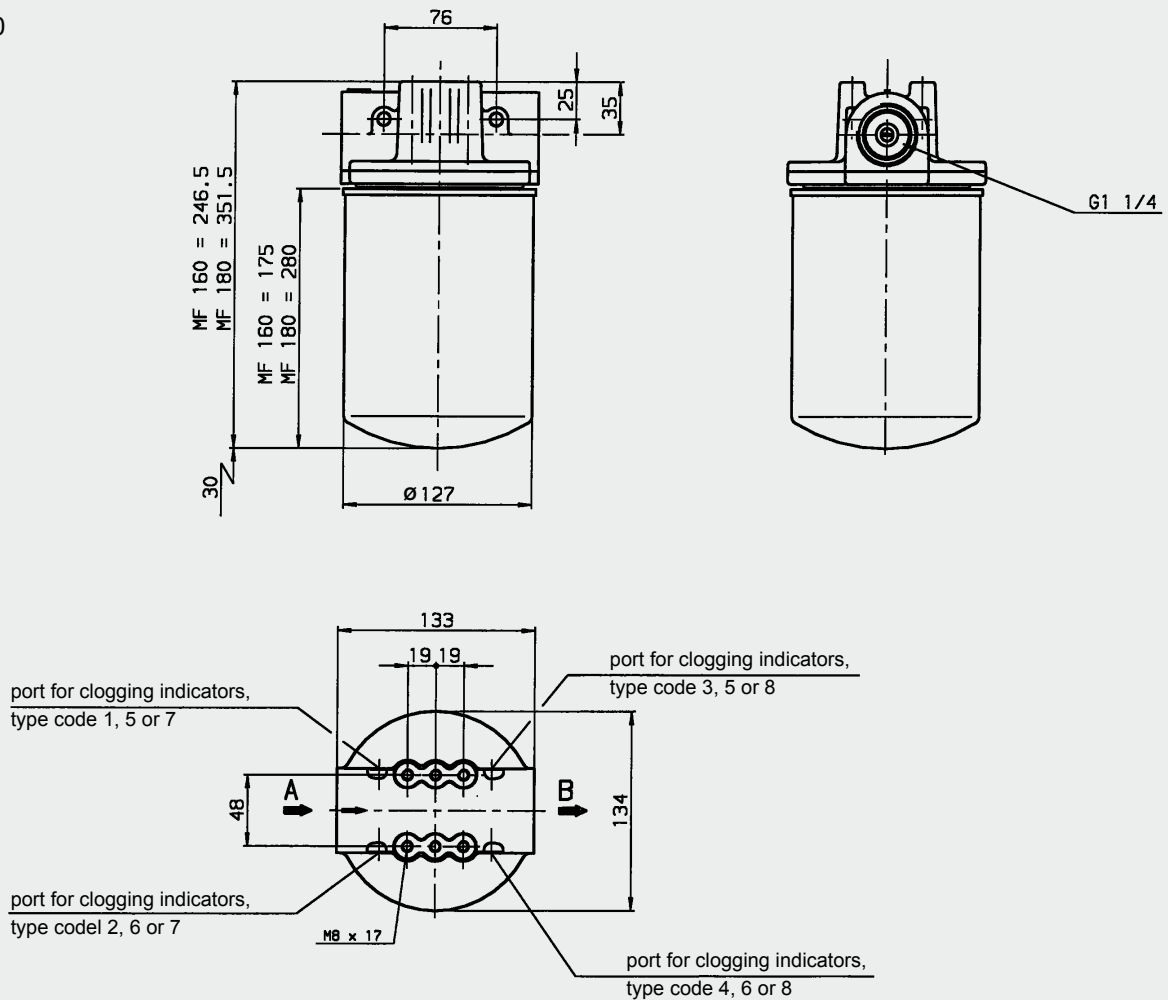

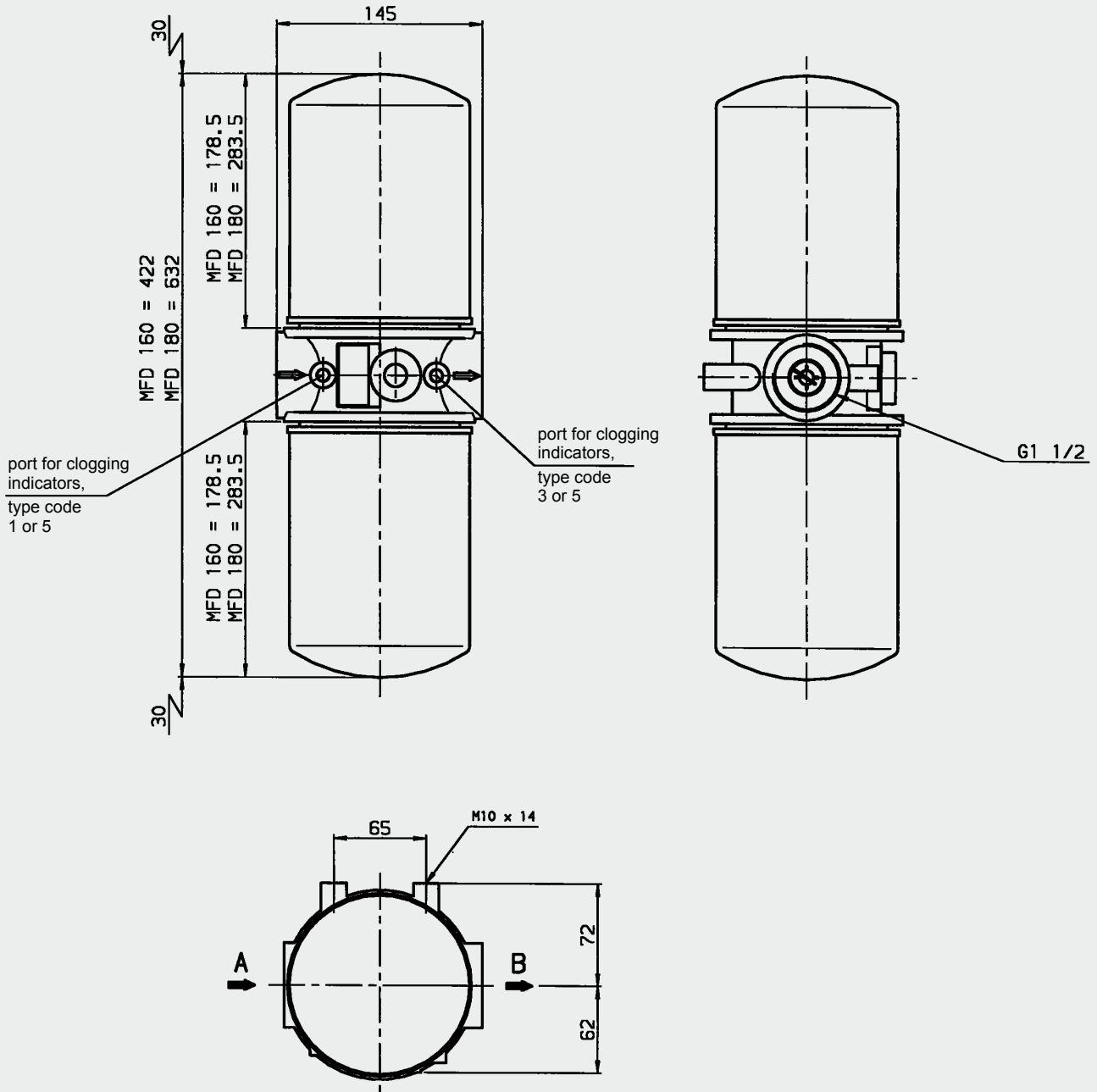

Summary

Filter type	Port size Inlet / Outlet	Port size Cartridge	Weight incl. element [kg]	Vol. of pressure chamber[l]
MF 80	G $\frac{3}{4}$	G $\frac{3}{4}$, 1-12 UNF	0.9	1.00
MF 160	G1 $\frac{1}{4}$	G1 $\frac{1}{4}$, 1 $\frac{1}{2}$ x16 UN-2B	2.3	2.00
MF 180	G1 $\frac{1}{4}$	1 $\frac{1}{2}$ x16 UN-2B	2.8	3.30
MFD 160	G1 $\frac{1}{2}$	G1 $\frac{1}{4}$, 1 $\frac{1}{2}$ x16 UN-2B	3.7	4.00
MFD 180	G1 $\frac{1}{2}$	1 $\frac{1}{2}$ x16 UN-2B	4.5	6.60

NOTE

The information in this brochure relates to the operating conditions and applications described.
 For applications or operating conditions not described, please contact the relevant technical department.
 Subject to technical modifications.

HYDAC Filbertechnik GmbH
 Industriegebiet
D-66280 Sulzbach/Saar
 Tel.: 0 68 97 / 509-01
 Fax: 0 68 97 / 509-300
 Internet: www.hydac.com
 E-Mail: filter@hydac.com