

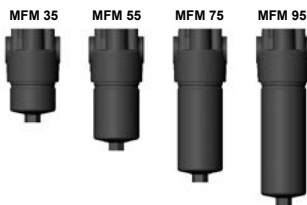

## Inline Filter MFM

up to 100 l/min, up to 280 bar



### 1. TECHNICAL SPECIFICATIONS

#### 1.1 FILTER HOUSING

##### Construction

The filter housings are designed in accordance with international regulations. They consist of a filter head with screw-in filter bowl.

Standard equipment:

- with bypass valve
- connection for a clogging indicator on the top of the head as standard (4 mounting holes)
- Filters are supplied phosphate-plated and primed.

#### 1.2 FILTER ELEMENTS

HYDAC filter elements are validated and their quality is constantly monitored according to the following standards:

- ISO 2941
- ISO 2942
- ISO 2943
- ISO 3724
- ISO 3968
- ISO 11170
- ISO 16889

#### Contamination retention capacities in g

Betamicron® BN4HC

MFM	3 µm	5 µm	10 µm	20 µm
35	7.2	8.1	8.6	8.8
55	14	15.8	16.6	17.2
75	21.6	24.3	25.7	26.5
95	27.5	30.9	32.7	33.7

Filter elements are available with the following pressure stability values:  
Betamicron® (BN4HC): 20 bar

#### 1.3 FILTER SPECIFICATIONS

Nominal pressure	280 bar
Fatigue strength	0...280 bar, min. 10 <sup>7</sup> load cycles 0...320 bar, min. 10 <sup>5</sup> load cycles
Temperature range	-10 °C to +100 °C (-30 °C to -10 °C: p <sub>max</sub> = 140 bar)
Material of filter head	EN-GJS-400-15
Material of filter bowl	Steel
Type of clogging indicator	VD (differential pressure indicator up to 420 bar operating pressure)
Pressure setting of clogging indicator	5 bar (others on request)
Bypass cracking pressure	7 bar (others on request)

#### 1.4 SEALS

NBR (= Perbunan)

#### 1.5 MOUNTING

As inline filter

#### 1.6 SPECIAL MODELS AND ACCESSORIES

Connection for a clogging indicator on the side of the head (3 mounting holes)

#### 1.7 SPARE PARTS

See Original Spare Parts List

#### 1.8 CERTIFICATES AND APPROVALS

On request

#### 1.9 COMPATIBILITY WITH HYDRAULIC FLUIDS TO ISO 2943

- Hydraulic oils H to HLPD DIN 51524
- Lubrication oils DIN 51517, API, ACEA, DIN 51515, ISO 6743
- Compressor oils DIN 51506
- Biodegradable operating fluids VDMA 24568 HETG, HEES, HEPG
- Operating fluids with high water content (>50% water content) on request

#### 1.10 IMPORTANT INFORMATION

- Filter housing must be earthed
- When using electrical clogging indicators, the electrical power supply to the system must be switched off before removing the clogging indicator connector.

#### Symbol for hydraulic systems

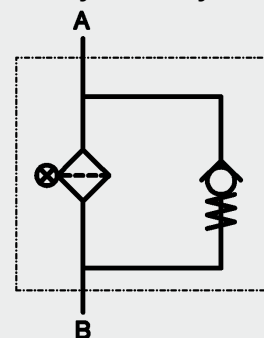

## 2. MODEL CODE (also order example)

**MFM BN/HC 55 O D 10 D 4 . X /-L24**

### 2.1 COMPLETE FILTER

**Filter type** \_\_\_\_\_

MFM

**Filter material of element** \_\_\_\_\_

BN/HC Betamicon® (BN4HC)

**Size of filter or element** \_\_\_\_\_

MFM: 35, 55, 75, 95

**Operating pressure** \_\_\_\_\_

O = 280 bar

**Type and size of port** \_\_\_\_\_

Type	Port	Filter size			
		35	55	75	95
A	M18 x 1.5	●	●	●	●
B	G ½	●	●	●	●
D	M22 x 1.5	●	●	●	●
H	G ¾	●	●	●	●

**Filtration rating in µm** \_\_\_\_\_

BN4HC: 3, 5, 10, 20

**Type of clogging indicator** \_\_\_\_\_

W without port for clogging indicator

A with steel blanking plug in indicator port

B visual

C electrical

D visual and electrical

for other clogging indicators  
see brochure no. 7.050../..

**Type code** \_\_\_\_\_

3 clogging indicator port on side of head - 3 mounting holes

4 clogging indicator port on top of head - 4 mounting holes

**Modification number** \_\_\_\_\_

X the latest version is always supplied

**Supplementary details** \_\_\_\_\_

B7 standard: cracking pressure of bypass 7 bar

L... light with appropriate voltage (24, 48, 110, 220 Volt)

LED 2 light emitting diodes up to 24 volt

V FPM seals

W suitable for HFA and HFC emulsions

WAL right-angled bracket for side mounting, inlet on left (only possible for type code 4.x)

WAR right-angled bracket for side mounting, inlet on right (only possible for type code 4.x)

only for clogging  
indicators type D

### 2.2 REPLACEMENT ELEMENT

**0055 D 010 BN4HC /-V**

**Size** \_\_\_\_\_

0035, 0055, 0075, 0095

**Type** \_\_\_\_\_

D

**Filtration rating in µm** \_\_\_\_\_

BN4HC: 003, 005, 010, 020

**Filter material** \_\_\_\_\_

BN4HC

**Supplementary details** \_\_\_\_\_

V (for descriptions, see point 2.1)

### 2.3 REPLACEMENT CLOGGING INDICATOR

**VD 5 D . X /-L24**

**Type** \_\_\_\_\_

VD differential pressure indicator up to 420 bar operating pressure

**Pressure setting** \_\_\_\_\_

5 standard 5 bar, others on request

**Type of clogging indicator** \_\_\_\_\_

D (see point 2.1)

**Modification number** \_\_\_\_\_

X the latest version is always supplied

**Supplementary details** \_\_\_\_\_

L..., LED, V, W (for descriptions, see point 2.1)

### 3. FILTER CALCULATION / SIZING

The total pressure drop of a filter at a certain flow rate Q is the sum of the housing  $\Delta p$  and element  $\Delta p$  and is calculated as follows:

$$\Delta p_{\text{total}} = \Delta p_{\text{housing}} + \Delta p_{\text{element}}$$

$$\Delta p_{\text{housing}} = (\text{see point 3.1})$$

$$\Delta p_{\text{Element}} = Q \cdot \frac{SK^*}{1000} \cdot \frac{\text{viscosity}}{30}$$

(\*see point 3.2)

For ease of calculation, our Filter Sizing Program is available on request free of charge.

**NEW:** Sizing online at [www.hydac.com](http://www.hydac.com)

#### 3.1 $\Delta P$ -Q HOUSING GRAPHS BASED ON ISO 3968

The housing graphs apply to mineral oil with a density of 0.86 kg/dm<sup>3</sup> and a kinematic viscosity of 30 mm<sup>2</sup>/s.

In this case, the differential pressure changes proportionally to the density.

##### MFM - Port M18 x 1.5 / G 1/2

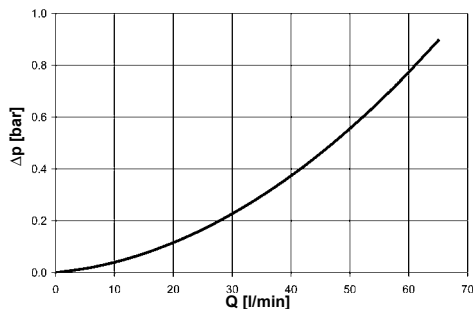

##### MFM - Port M22 x 1.5 / G 3/4

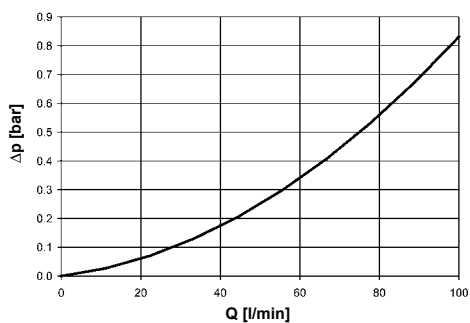

### 3.2 GRADIENT COEFFICIENTS (SK) FOR FILTER ELEMENTS

The gradient coefficients in mbar/(l/min) apply to mineral oils with a kinematic viscosity of 30 mm<sup>2</sup>/s. The pressure drop changes proportionally to the change in viscosity.

MFM	BN4HC			
	3 μm	5 μm	10 μm	20 μm
35	23.6	19.0	14.8	9.3
55	13.7	11.0	8.1	4.8
75	9.3	7.5	5.3	3.1
95	7.5	6.0	4.1	2.4

#### BN4HC: MFM 35

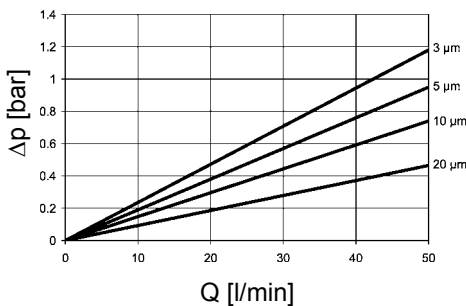

#### BN4HC: MFM 75

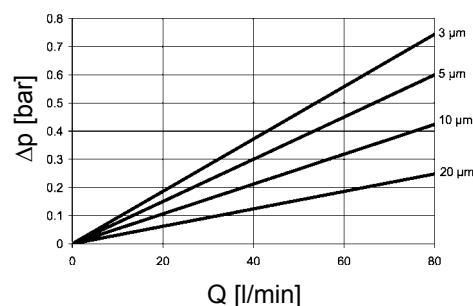

#### BN4HC: MFM 55

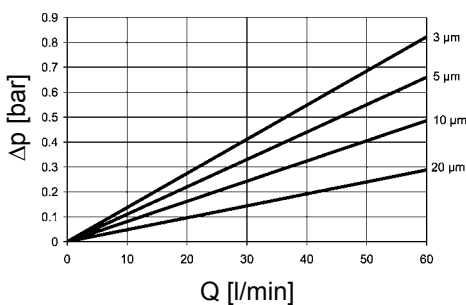

#### BN4HC: MFM 95

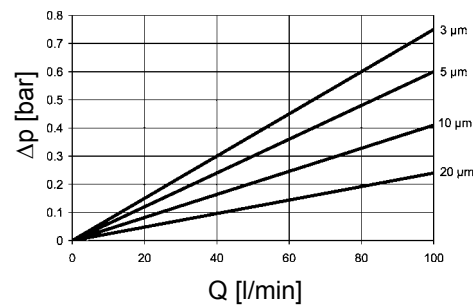

## 4. DIMENSIONS

STANDARD: VERSION 4.X

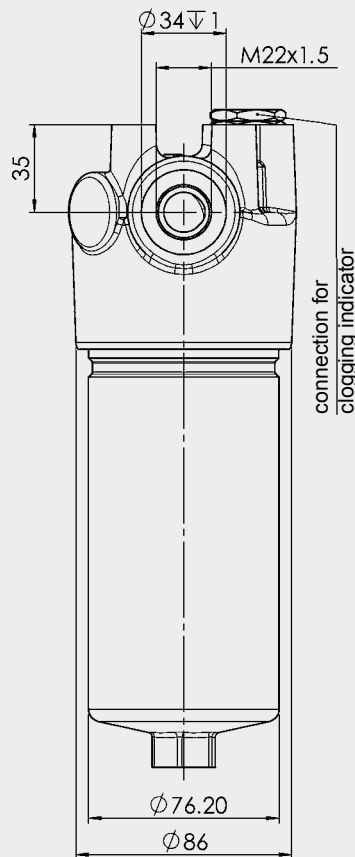
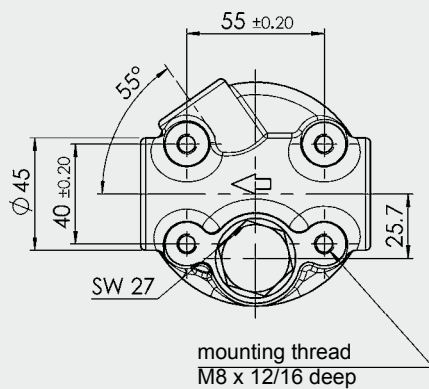
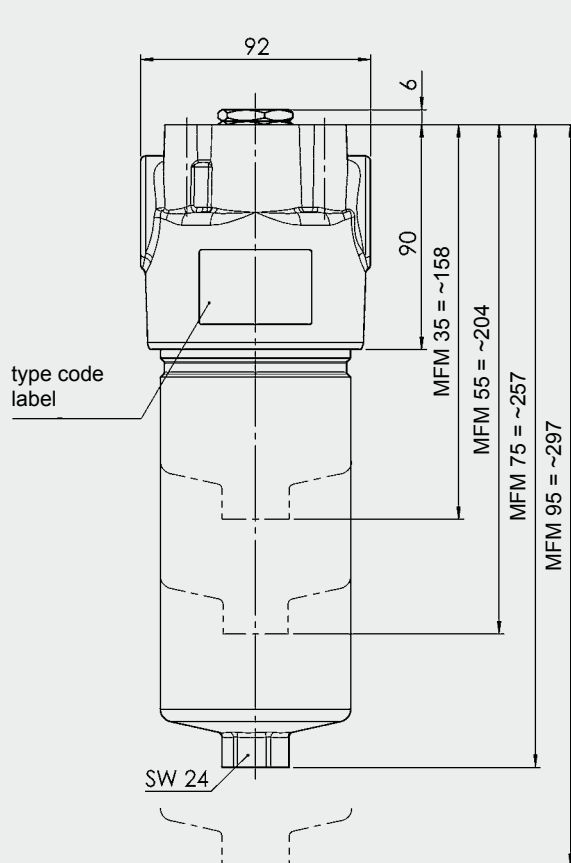

SPECIAL VERSION 3.X

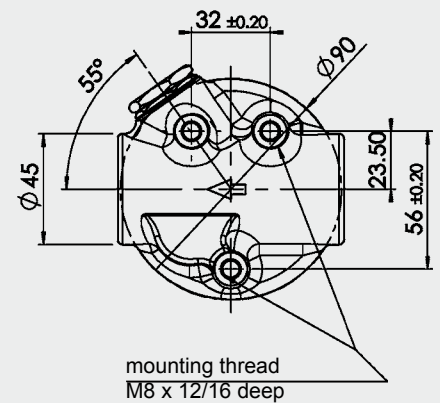
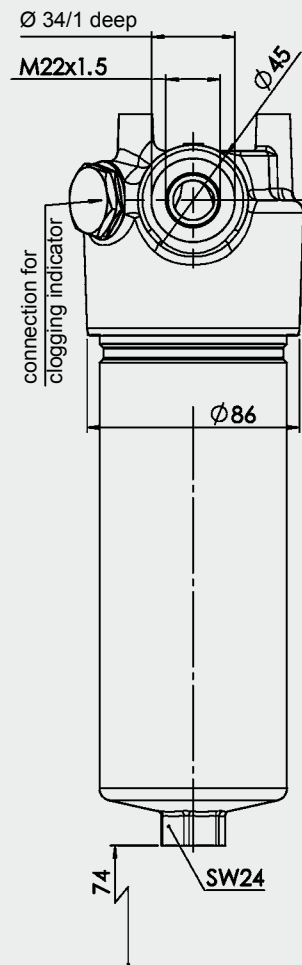

MFM	Weight incl. element [kg]	Vol. of pressure chamber [l]
35	3.7	0.24
55	4.2	0.39
75	4.7	0.56
95	5.1	0.69

### NOTE

The information in this brochure relates to the operating conditions and applications described.

For applications or operating conditions not described, please contact the relevant technical department.

Subject to technical modifications.

**HYDAC** Filtrertechnik GmbH  
 Industriegebiet  
**D-66280 Sulzbach/Saar**  
 Tel.: 0 68 97 / 509-01  
 Fax: 0 68 97 / 509-300  
 Internet: [www.hydac.com](http://www.hydac.com)  
 E-Mail: [filter@hydac.com](mailto:filter@hydac.com)