

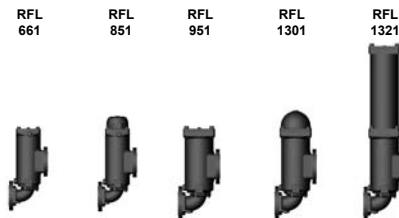

## Inline Filter RFL Cast Version up to 1300 l/min, up to 40 bar



### 1. TECHNICAL SPECIFICATIONS

#### 1.1 FILTER HOUSING

##### Construction

The filter housings are designed in accordance with international regulations. They consist of a two-piece filter housing with a bolt-on cover plate.

Standard equipment:

- connections for venting and draining
- connection for a clogging indicator

#### 1.2 FILTER ELEMENTS

Hydac filter elements are validated and their quality is constantly monitored according to the following standards:

- ISO 2941
- ISO 2942
- ISO 2943
- ISO 3724
- ISO 3968
- ISO 11170
- ISO 16889

#### Contamination retention capacities in g

		Betamicon® (BN4HC)			
RFL	Elements	3 µm	5 µm	10 µm	20 µm
66x	1x0660 R	87.1	96.5	116.1	131.3
85x	1x0850 R	112.1	124.2	149.5	169.1
95x	1x0950 R	130.0	144.1	173.3	196.1
130x	1x1300 R	181.0	200.7	241.4	273.1
132x	1x2600 R	369.4	409.4	492.5	557.2

Filter elements are available with the following pressure stability values:

Betamicon® (BN4HC):	20 bar
Paper (P/HC):	10 bar
Wire mesh (W/HC):	20 bar
Stainless steel fibre (V):	30 bar
Betamicon®/Aquamicron® (BN4AM):	10 bar
Aquamicron® (AM):	10 bar

#### 1.3 FILTER SPECIFICATIONS

Nominal pressure	25 bar 40 bar (RFL 662 to 1322 to AD)
Temperature range	-10 °C to +100 °C
Material of filter housing and cover plate	EN-GJS-400-15 : RFL 661 to 1321 GP 240 GH+N : RFL 662 to 1322 1.4581/4571 : RFL 853* On RFL 1321 and 1322 the extension is in steel!
Type of clogging indicator	VM (differential pressure measurement up to 210 bar operating pressure)
Pressure setting of clogging indicator	2 bar (others on request)
Bypass cracking pressure	3 bar (others on request)

#### 1.4 SEALS

NBR (= Perbunan)

#### 1.5 MOUNTING

As inline filter

#### 1.6 SPECIAL MODELS AND ACCESSORIES

- Inlet and outlet positioned one above the other
- Counter flanges as welding or blank flanges

#### 1.7 SPARE PARTS

See Original Spare Parts List

#### 1.8 CERTIFICATES AND APPROVALS

Material code (final digit of filter size) - 1:

These filters can be supplied with manufacturer's certificates O and M to DIN 55350, Part 18.

Test certificates 3.1 to DIN EN 10204 and approval certificates (Type Approval) for different approval authorities.

Areas of application, amongst others: lubrication.

Material code (final digit of filter size) - 2:

These filters are designed according to API 614, which contains guidelines for the design and designation of basic types of oil supply systems for bearings and shaft seals of larger machines.

Material code (final digit of filter size) - 3:

Filters for use in separation technology with low viscosity, high viscosity and aggressive fluids as well as gaseous media.\*

#### 1.9 COMPATIBILITY WITH HYDRAULIC FLUIDS ISO 2943

- Hydraulic oils H to HLPD DIN 51524
- Lubrication oils DIN 51517, API, ACEA, DIN 51515, ISO 6743
- Compressor oils DIN 51506
- Biodegradable operating fluids VDMA 24568 HETG, HEES, HEPG
- Non-flam operating fluids HFA, HFB, HFC and HFD
- Operating fluids with high water content (>50% water content) on request

#### 1.10 IMPORTANT INFORMATION

- Filter housing must be earthed
- When using electrical clogging indicators, the electrical power supply to the system must be switched off before removing the clogging indicator connector
- Filters must be flexibly mounted and not fixed rigidly to the floor or used as a pipe support.

#### Symbol for hydraulic systems

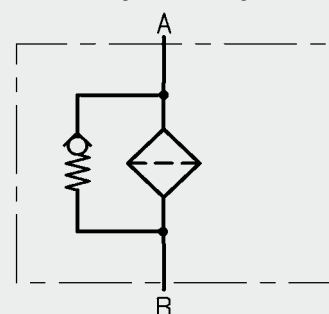

\* These filters are available from our Process Technology Department:  
HYDAC PROCESS TECHNOLOGY GMBH  
Industriegebiet Grube König  
Am Wrangelflöz 1  
D-66583 Neunkirchen  
Tel.: +49 (0)6821 - 86 90-0  
Fax: +49 (0)6821 - 86 90-200  
Email: prozess-technik@hydac.com

## 2. MODEL CODE (also order example)

RFL BN/HC 851 D N 10 D 1 . X /-L24

### 2.1 COMPLETE FILTER

Filter type \_\_\_\_\_

RFL

Filter material of element \_\_\_\_\_

BN/HC Betamicon® (BN4HC) P/HC Paper AM Aquamicon®  
 V Stainless steel fibre W/HC Wire mesh BN/AM Betamicon®/Aquamicon®

Size of filter or element \_\_\_\_\_

RFL: 661, 662, 851, 853, 951, 952, 1301, 1302, 1321, 1322

Operating pressure \_\_\_\_\_

D = 25 bar

E = 40 bar (RFL 662-1322 to AD)

Type and size of port \_\_\_\_\_

Type	Port	Filter size					
		661	851	951	1301	1321	
		662	853	952	1302	1322	
N	SAE DN 80 (3")	●	●				
P	SAE DN 100 (4")			●	●	●	
Q	DIN DN 80	●	●				
R	DIN DN 100			●	●	●	

Other nominal widths and ANSI ports on request

Filtration rating in µm \_\_\_\_\_

BN/HC, V: 3, 5, 10, 20 P/HC: 10, 20 AM: 40

W/HC: 25, 50, 100, 200 BN/AM: 3, 10

Type of clogging indicator \_\_\_\_\_

Y plastic blanking plug in indicator port

A steel blanking plug in indicator port

B visual

C electrical

D visual and electrical

for other clogging indicators  
 see brochure no. E 7.050../..

Type code \_\_\_\_\_

1

Modification number \_\_\_\_\_

X the latest version is always supplied

Supplementary details \_\_\_\_\_

B. special cracking pressure of bypass (e.g. B1 = 1 bar)

GA counter flange as welding flange

GB counter flange as blank flange

KB without bypass flange

L... light with appropriate voltage (24V, 48V, 110V, 220V)

LED 2 light emitting diodes up to 24 Volt

OR O-ring groove on the DIN flange (inlet and outlet) to Rexroth standard AB 22-04

V FPM seals

33 inlet and outlet positioned one above the other

SAK contamination retainer

only for clogging indicators  
 type D

### 2.2 REPLACEMENT ELEMENT

0850 R 010 BN4HC /-V

Size \_\_\_\_\_

0660, 0850, 0950, 1300, 2600

Type \_\_\_\_\_

R

Filtration rating in µm \_\_\_\_\_

BN4HC, V: 003, 005, 010, 020 P/HC: 010, 020 AM: 040

W/HC: 025, 050, 100, 200 BN4AM: 003, 010

Filter material \_\_\_\_\_

BN4HC, V, W/HC, P/HC, BN4AM, AM

Supplementary details \_\_\_\_\_

V (for descriptions, see point 2.1)

### 2.3 REPLACEMENT CLOGGING INDICATOR

VM 2 D . X /-L24

Type \_\_\_\_\_

VM differential pressure measurement up to 210 bar operating pressure

Pressure setting \_\_\_\_\_

2 2 bar standard, others on request

Type of clogging indicator (see point 2.1) \_\_\_\_\_

Modification number \_\_\_\_\_

X the latest version is always supplied

Supplementary details \_\_\_\_\_

L..., LED, V (for descriptions, see point 2.1)

### 3. FILTER CALCULATION / SIZING

The total pressure drop of a filter at a certain flow rate Q is the sum of the housing  $\Delta p$  and element  $\Delta p$  and is calculated as follows:

$$\Delta p_{\text{total}} = \Delta p_{\text{housing}} + \Delta p_{\text{element}}$$

$$\Delta p_{\text{housing}} = (\text{see point 3.1})$$

$$\Delta p_{\text{element}} = Q \cdot \frac{SK^*}{1000} \cdot \frac{\text{viscosity}}{30}$$

(\*see point 3.2)

For ease of calculation, our Filter Sizing Program is available on request free of charge.

**NEW:** Sizing online at [www.hydac.com](http://www.hydac.com)

#### 3.1 $\Delta p$ -Q HOUSING GRAPHS BASED ON ISO 3968

The housing graphs apply to mineral oil with a density of 0.86 kg/dm<sup>3</sup> and a kinematic viscosity of 30 mm<sup>2</sup>/s. In this case, the differential pressure changes proportionally to the density.

##### RFL 661, 662, 851, 853

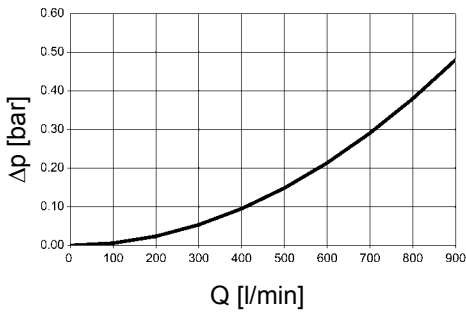

##### RFL 951, 952, 1301, 1302, 1321, 1322

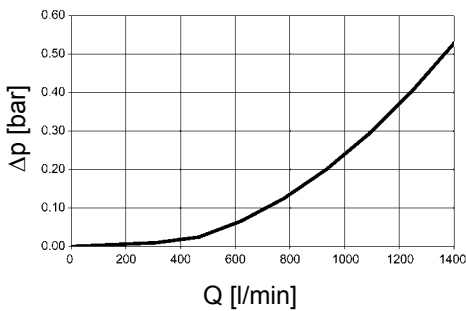

### 3.2 GRADIENT COEFFICIENTS (SK) FOR FILTER ELEMENTS

The gradient coefficients in mbar/(l/min) apply to mineral oils with a kinematic viscosity of 30 mm<sup>2</sup>/s. The pressure drop changes proportionally to the change in viscosity.

RFL	V				W/HC
	3 μm	5 μm	10 μm	20 μm	
660	1.0	0.8	0.6	0.4	0.081
850	0.8	0.6	0.4	0.3	0.063
950	0.7	0.6	0.4	0.2	0.054
1300	0.5	0.4	0.3	0.2	0.045
2600	0.3	0.2	0.1	0.1	0.022

#### BN4HC: RFL 660

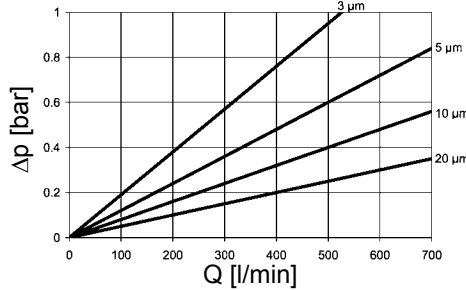

#### BN4HC: RFL 1300

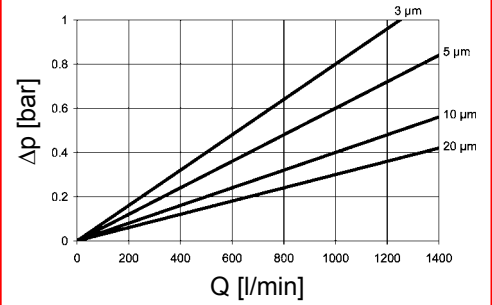

#### BN4HC: RFL 850

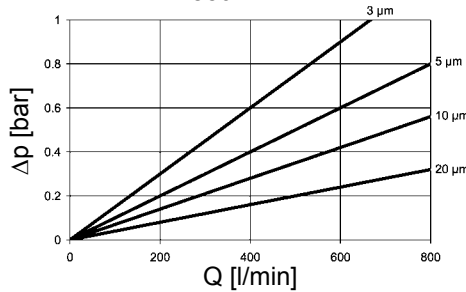

#### BN4HC: RFL 2600

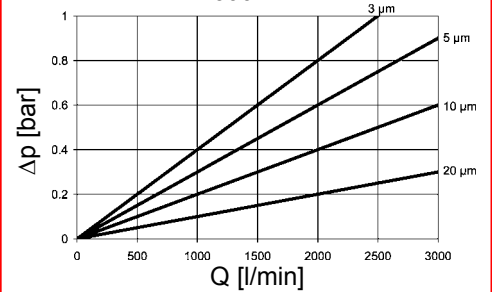

#### BN4HC: RFL 950

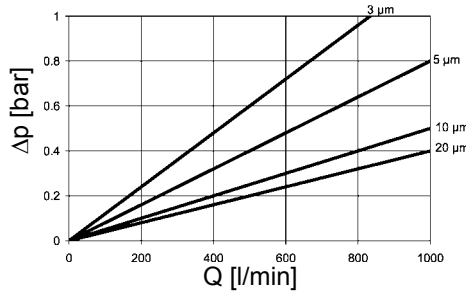

## 4. DIMENSIONS

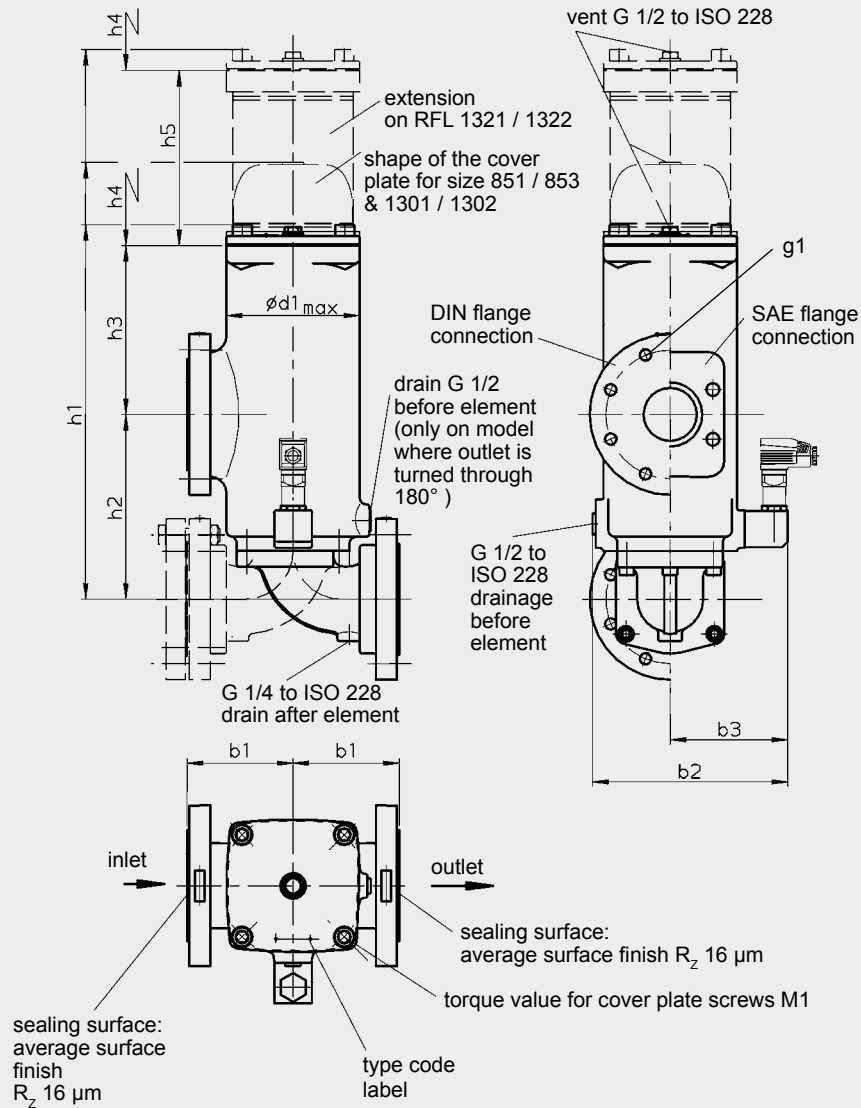

RFL	Flange port	b1	b2	b3	d1	h1	h2	h3	h4	h5 (Nm)	M1	g1	Weight including element [kg]	Volume of pressure chamber [l]
661	SAE DN 80 DIN DN 80	133	192 184	239	172	465	230	210	350	-	150	M16 M16	36	8.2
662	SAE DN 80 DIN DN 80	133	192 184	239	172	465	230	210	350	-	150	M16 M16	42	8.2
851	SAE DN 80 DIN DN 80	133	192 184	239	172	552	230	210	420	-	150	M16 M16	38.5	9.5
853	SAE DN 80 DIN DN 80	133	192 184	239	172	552	230	210	420	-	150	M16 M16	45	9.5
951	SAE DN 100 DIN DN 100	143	223 215	267	220	523	250	238	380	-	250	M16 M20	54	13
952	SAE DN 100 DIN DN 100	143	223 215	267	220	523	250	238	380	-	250	M16 M20	67.5	13
1301	SAE DN 100 DIN DN 100	143	223 215	267	220	630	250	238	500	-	250	M16 M20	55.5	16
1302	SAE DN 100 DIN DN 100	143	223 215	267	220	630	250	238	500	-	250	M16 M20	75.5	16
1321	SAE DN 100 DIN DN 100	143	223 215	267	220	1084	250	238	940	561	250	M16 M20	82	31
1322	SAE DN 100 DIN DN 100	143	223 215	267	220	1084	250	238	940	561	250	M16 M20	96	31

### NOTE

The information in this brochure relates to the operating conditions and applications described.

For applications or operating conditions not described, please contact the relevant technical department.

Subject to technical modifications.

**HYDAC** Filtrertechnik GmbH  
 Industriegebiet  
**D-66280 Sulzbach/Saar**  
 Tel.: 0 68 97 / 509-01  
 Fax: 0 68 97 / 509-300  
 Internet: [www.hydac.com](http://www.hydac.com)  
 E-Mail: [filter@hydac.com](mailto:filter@hydac.com)