



## Tank-Top Return Line Filter RFND Change-Over Version to DIN 24550 up to 630 l/min, up to 10 bar



### 1. TECHNICAL SPECIFICATIONS

#### 1.1 FILTER HOUSING

##### Construction

The filter housings are designed in accordance with international regulations. Each housing consists of a filter head, filter bowl and screw-on cover plate.

Standard equipment:

- with bypass valve
- connection for a clogging indicator

#### 1.2 FILTER ELEMENTS

Hydac filter elements are validated and their quality is constantly monitored according to the following standards:

- ISO 2941
- ISO 2942
- ISO 2943
- ISO 3724
- ISO 3968
- ISO 11170
- ISO 16889

#### Contamination retention capacities in g

RFND	Betamicon® BN4HC			
	3 µm	6 µm	10 µm	25 µm
100	22.0	24.7	27.5	33.0
250	61.4	69.1	76.8	92.1
630	148.6	167.3	185.8	222.9

Filter elements are available with the following pressure stability values:  
Betamicon® (BN4HC): 20 bar

#### 1.3 FILTER SPECIFICATIONS

Nominal pressure	10 bar
Temperature range	-10 °C to +100 °C
Material of filter head	Aluminium
Material of filter bowl	Polyamide
Material of cover plate	Polyamide (RFN 100) Aluminium (RFN 250 and 630)
Type of clogging indicator	VR Connection thread G 1/2 VMF Connection thread G 1/8
Pressure setting of clogging indicator	2.5 bar (others on request)
Bypass cracking pressure	3.5 bar (others on request)

#### 1.4 SEALS

NBR (= Perbunan)

#### 1.5 MOUNTING

As tank-top filter

#### 1.6 SPECIAL MODELS AND ACCESSORIES

On request

#### 1.7 SPARE PARTS

See Original Spare Parts List

#### 1.8 CERTIFICATES AND APPROVALS

On request

#### 1.9 COMPATIBILITY WITH HYDRAULIC FLUIDS ISO 2943

- Hydraulic oils H to HLPD DIN 51524
- Lubrication oils DIN 51517, API, ACEA, DIN 51515, ISO 6743
- Compressor oils DIN 51506
- Biodegradable operating fluids VDMA 24568 HETG, HEES, HEPG
- Non-flam operating fluids HFA, HFB, HFC and HFD
- Operating fluids with high water content (>50% water content) on request

#### 1.10 IMPORTANT INFORMATION

- Filter housing must be earthed
- When using electrical clogging indicators, the electrical power supply to the system must be switched off before removing the clogging indicator connector

#### Symbol for hydraulic systems

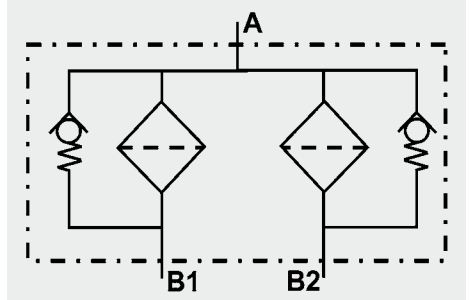

## 2. MODEL CODE (ALSO ORDER EXAMPLE)

**RFND BN/HC 250 B A E 10 D 1 . X /-L24**

### 2.1 COMPLETE FILTER

**Filter type** \_\_\_\_\_

RFND

**Filter material of element** \_\_\_\_\_

BN/HC Betamicon® (BN4HC)

**Size of filter or element** \_\_\_\_\_

RFND: 100, 250, 630

**Operating pressure** \_\_\_\_\_

B = 10 bar

**Type of change-over** \_\_\_\_\_

A ball

**Type and size of port** \_\_\_\_\_

Type	Port	Filter size		
		100	250	630
C	G 3/4	●		
E	G1 1/4		●	
L	SAE DN 50			●

**Filtration rating in µm** \_\_\_\_\_

BN4HC: 3, 6, 10, 25

**Type of clogging indicator** \_\_\_\_\_

Y plastic blanking plug in indicator port

A steel blanking plug in indicator port

B visual

C electrical

D visual and electrical

LZ visual-mechanical / electrical

for other clogging indicators  
see brochure no. E 7.050../..

**Type code** \_\_\_\_\_

1

**Modification number** \_\_\_\_\_

X the latest version is always supplied

**Supplementary details** \_\_\_\_\_

L... light with appropriate voltage (24V, 48V, 110V, 220V) ] only for clogging

LED 2 light emitting diodes up to 24 Volt ] indicators Type D

A V LZ indicator with plug to AUDI and VW specification

BO LZ indicator with plug and pin connection to BMW and Opel specification (M12x1)

CN LZ indicator with plug to DIN 43651 with 3 LEDs (CNOMO standard)

DB LZ indicator with plug to DIN 43651 with 3 LEDs (Daimler-Benz standard)

D4C LZ indicator with plug and pin connection to Daimler-Chrysler specification and cold start suppression 30 °C

BO-LED as for BO, but with progressive diode strip

GM LZ indicator with "no element" indicator

30C LZ indicator with temperature limiter (only in conjunction with type DB)

V FPM seals

W suitable for HFA and HFC emulsions

### 2.2 REPLACEMENT ELEMENT

**0250 RN 010 BN4HC /-V**

**Size** \_\_\_\_\_

0100, 0250, 0630

**Type** \_\_\_\_\_

RN

**Filtration rating in µm** \_\_\_\_\_

BN4HC: 003, 006, 010, 025

**Filter material** \_\_\_\_\_

BN4HC

**Supplementary details** \_\_\_\_\_

V (for descriptions, see point 2.1)

### 2.3 REPLACEMENT CLOGGING INDICATOR

**VR 2.5 D . X /-L24**

**Type** \_\_\_\_\_

VR Connection thread G 1/2

VMF Connection thread G 1/8

**Pressure setting** \_\_\_\_\_

2.5 2.5 bar standard, others on request

**Type of clogging indicator** \_\_\_\_\_

D (see point 2.1)

**Modification number** \_\_\_\_\_

X the latest version is always supplied

**Supplementary details** \_\_\_\_\_

L..., LED, V (for descriptions, see point 2.1)

### 3. FILTER CALCULATION / SIZING

The total pressure drop of a filter at a certain flow rate Q is the sum of the housing  $\Delta p$  and element  $\Delta p$  and is calculated as follows:

$$\Delta p_{\text{total}} = \Delta p_{\text{housing}} + \Delta p_{\text{element}}$$

$$\Delta p_{\text{housing}} = (\text{see point 3.1})$$

$$\Delta p_{\text{element}} = Q \cdot \frac{SK^*}{1000} \cdot \frac{\text{viscosity}}{30}$$

(\*see point 3.2)

For ease of calculation, our Filter Sizing Program is available on request free of charge.

**NEW:** Sizing online at [www.hydac.com](http://www.hydac.com)

#### 3.1 $\Delta p$ -Q HOUSING GRAPHS BASED ON ISO 3968

The housing graphs apply to mineral oil with a density of 0.86 kg/dm<sup>3</sup> and a kinematic viscosity of 30 mm<sup>2</sup>/s. In this case, the differential pressure changes proportionally to the density.

##### RFND 100

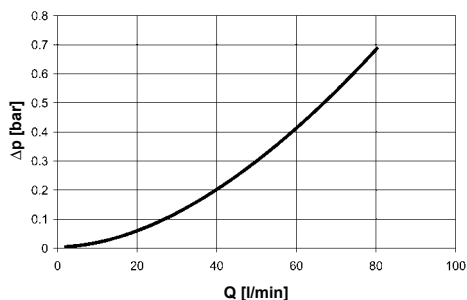

##### RFND 250

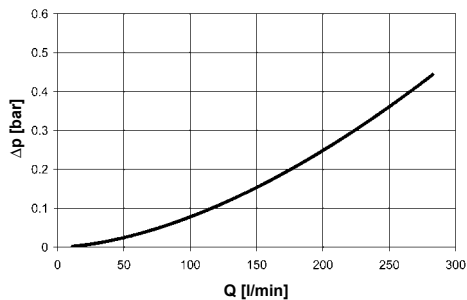

##### RFND 630

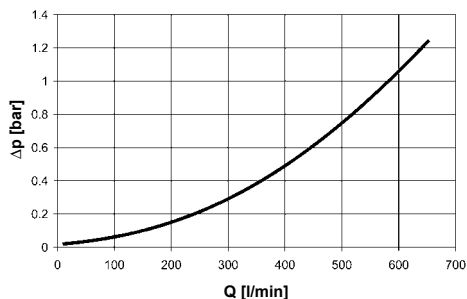

### 3.2 GRADIENT COEFFICIENTS (SK) FOR FILTER ELEMENTS

The gradient coefficients in mbar/(l/min) apply to mineral oils with a kinematic viscosity of 30 mm<sup>2</sup>/s. The pressure drop changes proportionally to the change in viscosity.

RFND	BN4HC			
	3 μm	6 μm	10 μm	25 μm
100	6.8	3.3	2.3	1.2
250	2.8	1.4	0.9	0.4
630	2.1	1.2	0.9	0.7

##### BN4HC: 100

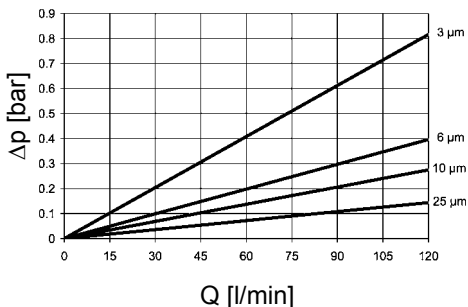

##### BN4HC: 630

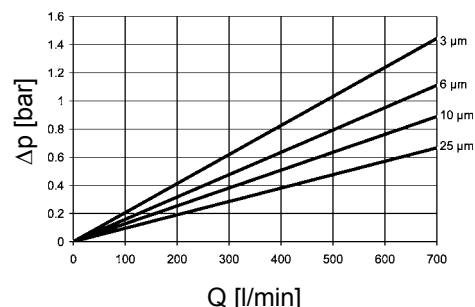

##### BN4HC: 250

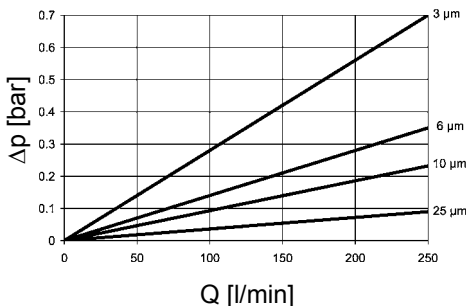

## 4. DIMENSIONS

RFND 100

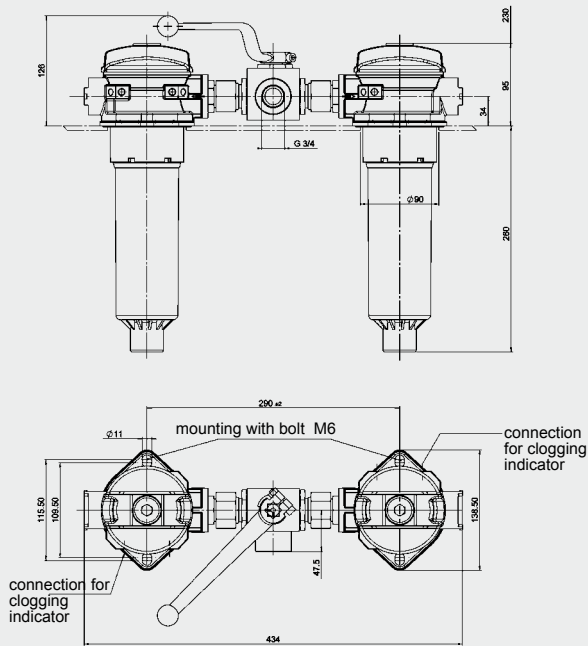

RFND 250

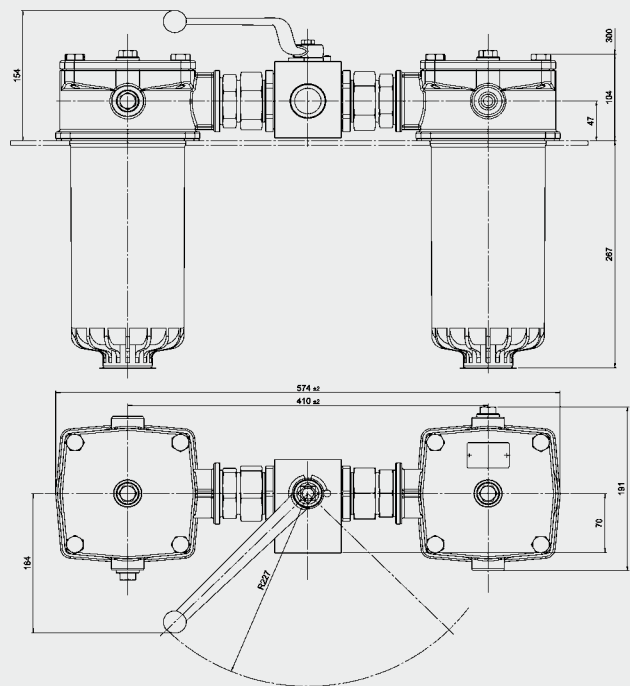

RFND 630

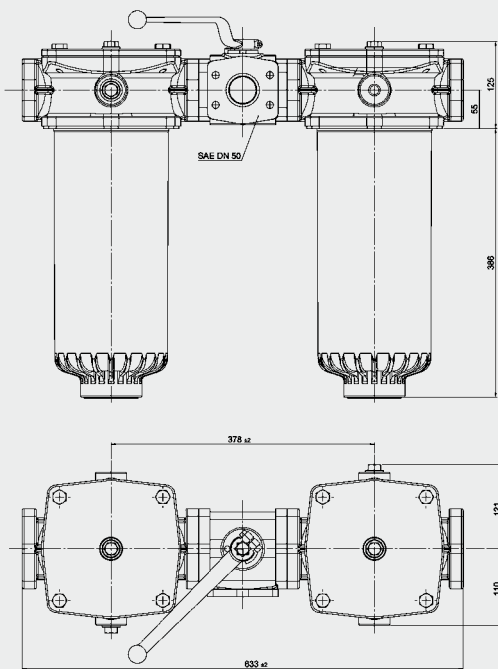

### Flange interface / opening in tank to DIN 24550

RFND 100

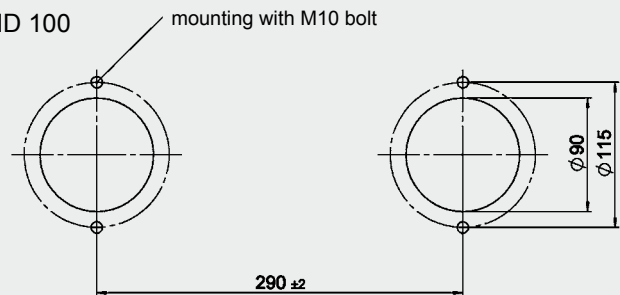

RFND 250

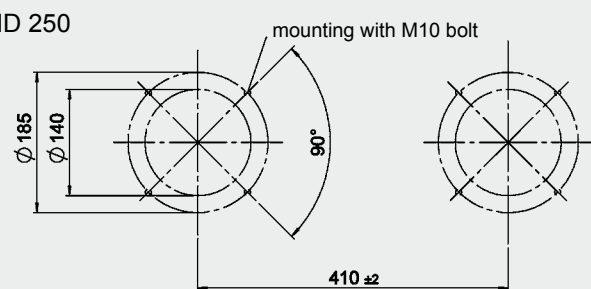

RFND 630

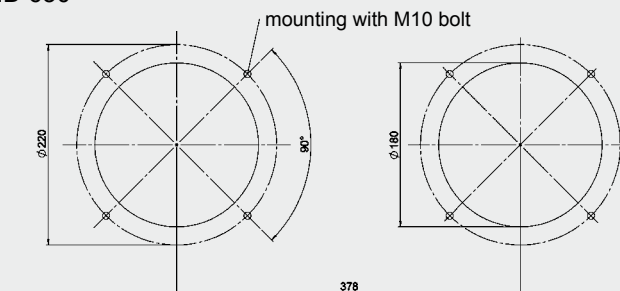

RFND	Weight incl. element [kg]	Vol. of pressure chamber[l]
100	5.4	2 x 1.00
250	13.0	2 x 3.50
630	23.0	2 x 8.00

### NOTE

The information in this brochure relates to the operating conditions and applications described.

For applications or operating conditions not described, please contact the relevant technical department.

Subject to technical modifications.

**HYDAC** Filbertechnik GmbH  
 Industriegebiet  
 D-66280 Sulzbach/Saar  
 Tel.: 0 68 97 / 509-01  
 Fax: 0 68 97 / 509-300  
 Internet: www.hydac.com  
 E-Mail: filter@hydac.com