

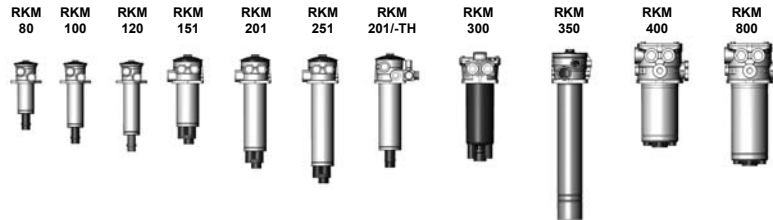

Return Line and Suction Boost Filter RKM up to 800 l/min, up to 10 bar



1. TECHNICAL SPECIFICATIONS

1.1 FILTER HOUSING

Construction

The filter housings are designed in accordance with international regulations. They consist of a filter head, filter bowl and a screw-on cover plate.

Standard equipment:

- with bypass valve
- with back-pressure valve
- without anti-cavitation valve

Application

RKM return line & suction boost filters are ideally suited for use in units with two or more circuits.

In particular this filter is the "first choice" for mobile machinery using hydrostatic drives (e.g. wheel loaders, fork-lift trucks, harvesting machines), if the return flow is greater than the flow required on the suction side under operating conditions.

Function

The return flow Q_R of the operating hydraulics is supplied to the filter via one or several inlets "A" and is cleaned by the filter element (full flow return line filtration). A pressure of 0.5 bar (standard) is applied inside the element by the back-pressure valve "V1". This ensures that the filtered return line flow is available to the hydrostatic feed pumps connected in "B" ports (full flow suction boost filtration). The risk of cavitation is significantly reduced. The excess flow is drained to the tank via port "T".

A bypass valve "V2" (standard = 2.5 bar) is fitted to relieve excessive back-pressures in the element (important on cold starts). This valve arrangement ensures that only finely filtered oil is available to the suction port during operation (exception: RKM 350). With optional valve "V3", oil can be drawn from the tank for short periods, e.g. initial filling, venting after changing the element.

1.2 FILTER ELEMENTS

The filter elements used in RKM filters are characterised by low back-pressures, especially at high viscosities (e.g. cold starts).

1.3 FILTER SPECIFICATIONS

Nominal pressure	10 bar
Temperature range	-30 °C to +100 °C (short-term -40 °C)
Material of filter head	Aluminium
Material of filter bowl	Steel (except RKM 300) Polyamide (RKM 300)
Material of cover plate	Polyamide (RKM 80 to 251, 350) Aluminium (RKM 300, 400, 800)
Type of clogging indicator	VMF – connection thread G 1/8
Pressure setting of clogging indicator	-0.2 bar (vacuum pressure) 2 bar (back-pressure) (others on request)
Bypass cracking pressure (V2)	2.5 bar (others on request)
Setting for back-pressure valve (V1)	0.5 bar (others on request)

Hydac filter elements are validated and their quality is constantly monitored according to the following standards:

- ISO 2941
- ISO 2942
- ISO 2943
- ISO 3724
- ISO 3968
- ISO 11170
- ISO 16889

Contamination retention capacities in g

RKM	Mobilemicron (MM)	
	10 µm	15 µm
80	11.0	13.3
100	16.3	19.6
120	20.7	25.0
151	26.6	31.4
201	50.9	61.4
251	61.9	74.7
300	55.6	67.1
350	87.0	105.0
400	67.4	81.3
800	86.3	104.2

Pressure stability value: 10 bar

1.4 SEALS

NBR (= Perbunan)

1.5 INSTALLATION

As tank-top mounted filter

1.6 SPECIAL MODELS AND ACCESSORIES

- air bleed valve
- integral thermal bypass valve (only RKM 151, 201, 251; see Point 2.5)
- anti-cavitation valve (V3)

1.7 SPARE PARTS

See Original Spare Parts List

1.8 CERTIFICATES AND APPROVALS

On request

1.9 COMPATIBILITY WITH HYDRAULIC FLUIDS ISO 2943

- Hydraulic oils H to HLPD DIN 51524
- Lubrication oils DIN 51517, API, ACEA, DIN 51515, ISO 6743
- Compressor oils DIN 51506
- Biodegradable operating fluids VDMA 24568 HETG, HEES, HEPG
- Non-flam operating fluids HFA, HFB, HFC and HFD
- Operating fluids with high water content (>50% water content) on request

1.10 IMPORTANT INFORMATION

- Filter housing must be earthed
- When using electrical clogging indicators, the electrical power supply to the system must be switched off before removing the clogging indicator connector.

Symbol for hydraulic systems

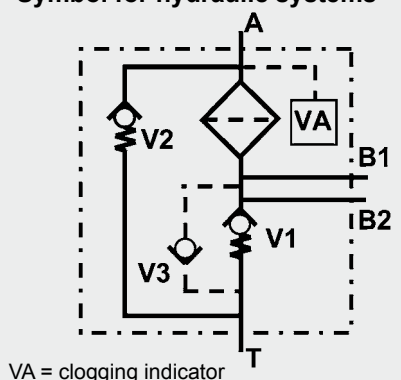

2. MODEL CODE (ALSO ORDER EXAMPLE)

RKM MM 300 B T F 10 W 0 . X /-NR-EV

2.1 COMPLETE FILTER

Filter type _____

RKM

Filter material of element _____

MM Mobilemicron

Size of filter or element _____

RKM: 80, 100, 120, 151, 201, 251, 300, 350, 400, 800

Operating pressure _____

B 10 bar

Type and size of suction line _____

Type	Port	Filter size									
		80	100	120	151	201	251	300	350	400	800
T	2 x CS1¼				●	●	●	●			
V	2 x G1				●	●	●				
X	1 x G1	●	●	●					●		
Y	1 x G¾	●	●	●							
Z	To customer spec.				●*	●*	●*			●	●

Type and size of return line _____

Type	Port	Filter size									
		80	100	120	151	201	251	300	350	400	800
C	1 x G¾	●	●	●							
D	1 x G1	●	●	●							
E	1 x G1¼				●	●	●				
F	1 x CS1½							●			
G	1 x G1½								●		
Z	To customer spec.				●*	●*	●*			●	●

*only in conjunction with thermal cooler bypass valve

Filtration rating in µm _____

MM: 10, 15

Type of clogging indicator _____

W no port for clogging indicator

Y plastic blanking plug in indicator port

A steel blanking plug in indicator port

F pressure switch

K return line and vacuum pressure gauge

R return line pressure gauge

UF vacuum switch

for other clogging indicators see brochure No. E 7.050../..

Type code _____

0 no indicator

1-5 see point 2.6

Modification number _____

X the latest version is always supplied

Supplementary details _____

No details = standard (without anti-cavitation valve; seals NBR; bypass valve 2.5 bar; back-pressure valve 0.5 bar)

B2 bypass valve with 2 bar cracking pressure

B3-CV3.5 bypass valve with 3 bar cracking pressure and back-pressure valve with 3.5 bar cracking pressure (only on RKM 350)

B6-CV3 bypass valve with 6 bar cracking pressure and back-pressure valve with 3 bar cracking pressure (only on RKM 100, 300)

ES vent plug

EV air bleed valve

NR anti-cavitation valve (not on RKM 350)

NRF125 anti-cavitation valve and coarse strainer 125 µm (not on RKM 350)

ND pressure release valve in back-pressure valve

UT filter suitable for use when immersed horizontally in oil

V FPM seals

xxxxxxx only RKM 400 and 800 (see point 2.4)

THxx only for RKM 151, 201, 251 (see point 2.5)

for symbols see point 2.7

2.2 REPLACEMENT ELEMENT

0300 RK 010 MM /-V

Size _____

0080, 0100, 0120, 0151, 0201, 0251, 0300, 0350, 0400, 0800

Type _____

RK

Filtration rating in µm _____

MM 010, 015

Filter material _____

MM

Supplementary details _____

V FPM seal

2.3 REPLACEMENT CLOGGING INDICATOR

VMF 2 F . X /-V

The return line indicator monitors the level of contamination in the element.

The vacuum indicator monitors the suction side pressure

Type _____

VMF connection thread G 1/8

Pressure setting _____

0.2 -0.2 bar (vacuum)

2 2 bar (back-pressure)

others on request

Type (see point 2.1) _____

Modification number _____

X the latest version is always supplied

Supplementary details _____

V FPM seal

2.4 PORT CONFIGURATION RKM 400 AND 800

Since there are numerous options for machining the ports on the head of the RKM 400/800, the code BZZ is selected here as standard. In order to determine the position and size of the ports, a 9-digit code is added as a supplementary detail. This is determined using the table below. Unused ports are indicated by a "0".

Example: RKM MM 400 BZZ 15 A 1.0 /-102CC2200

Position in code	1	2	3	4	5	6	7	8	9
Port	R1	R2	R3	S4	S5	S6	S7	S8	S9
SAE DN 50	①								
SAE DN 65	2								
G1		1	1	A	A	1	1	A	A
G1¼		2	②	B	B	②	②	B	B
G1½		3	3	③	③	3	3	C	C

R = Return line port; S = Suction port

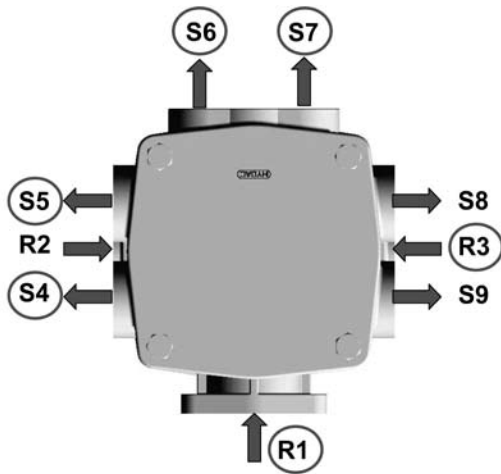

Diagram 1

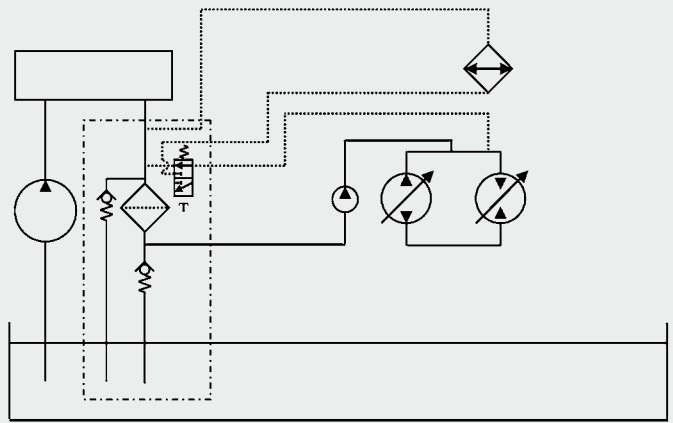
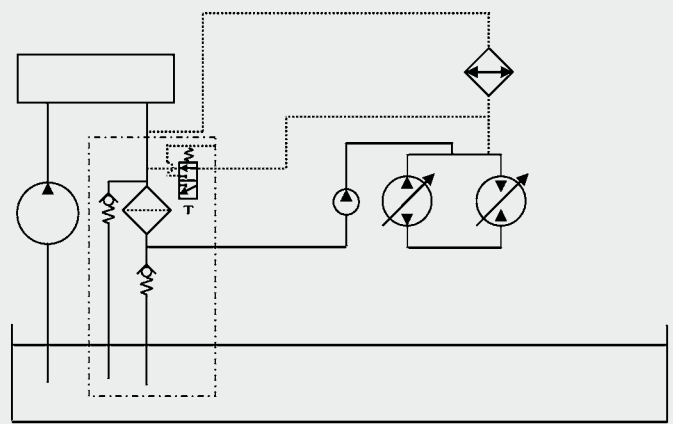

Diagram 2



2.5 PORT CONFIGURATION RKM 151, 201, 251 USING THERMAL COOLER BYPASS VALVE

The part flow which requires cooling can be directed via separate ports over the thermal valve. During a cold start, the spool of the thermal valve shuts off the flow to the cooler so that the fluid flows directly through the filter element. The position of the spool is regulated by the oil temperature. From approx. 50 - 60 °C the inlet to the cooler is completely open (diagram 1).

Alternative connection option according to diagram 2: A hose connects the inlet line of the cooler to the thermal valve.

The connection configuration is determined by agreement with the customer.

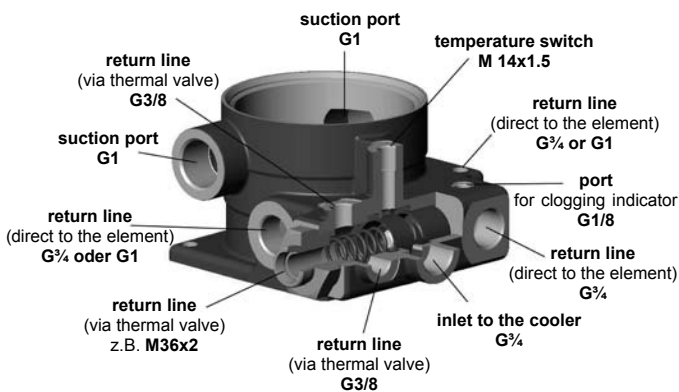

2.6 TYPE CODE

RKM 80, 100, 120

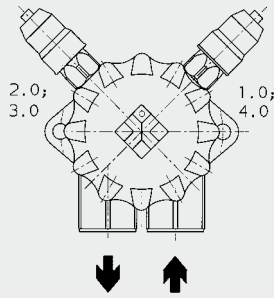

RKM 151, 201, 251

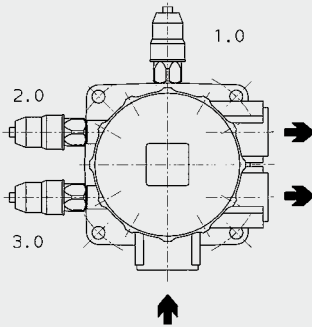

RKM 300

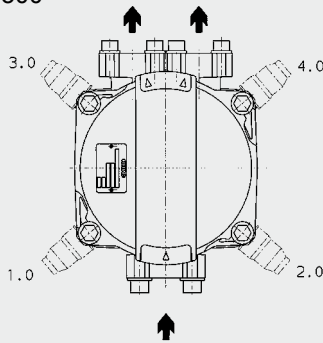

RKM 400, 800

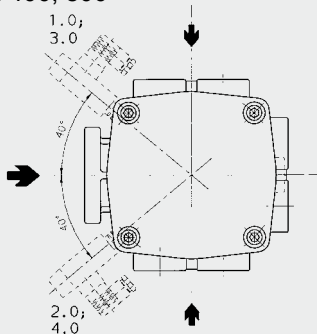

Type code	Mounting position of the clogging indicator	Type of clogging indicator	Measuring
1.X	On the filter inlet - right-hand side, bottom	Return line	Before the filter element
2.X	On the filter inlet - left-hand side, bottom	Return line	Before the filter element
3.X	On the filter outlet - right-hand side, top	Vacuum	After the filter element
4.X	On the filter outlet - left-hand side, top	Vacuum	After the filter element
5.X	Type code 1.X and 3.X	2 indicators: return line & vacuum	Before & after element

Type code	Mounting position of the clogging indicator	Type of clogging indicator	Measuring
1.X	Opposite the filter inlet	Return line	Before the filter element
2.X	On the filter inlet - left-hand side	Return line	Before the filter element
3.X	On the filter inlet - right-hand side	Vacuum	After the filter element
5.X	Type code 1.X and 3.X	2 indicators: return line & vacuum	Before & after element

Type code	Mounting position of the clogging indicator	Type of clogging indicator	Measuring
1.X	On the filter inlet - left-hand side	Return line	Before the filter element
2.X	On the filter inlet - right-hand side	Return line	Before the filter element
3.X	On the filter outlet - left-hand side	Vacuum	After the filter element
4.X	On the filter outlet - right-hand side	Vacuum	After the filter element
5.X	Type code 1.X and 3.X	2 indicators: return line & vacuum	Before & after element

Type code	Mounting position of the clogging indicator	Type of clogging indicator	Measuring
1.X	On the filter inlet - left-hand side, bottom	Return line	Before the filter element
2.X	On the filter inlet - right-hand side, bottom	Return line	Before the filter element
3.X	On the filter inlet - left-hand side, top	Vacuum	After the filter element
4.X	On the filter inlet - right-hand side, top	Vacuum	After the filter element
5.X	Type code 1.X and 3.X	2 indicators: return line & vacuum	Before & after element

Other indicator configurations on request!

2.7 SYMBOLS

/-NR

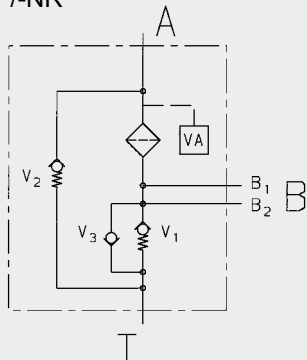

/-NRF125

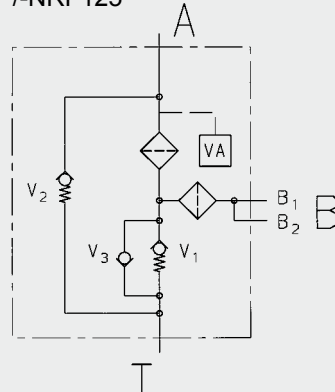

/-ND

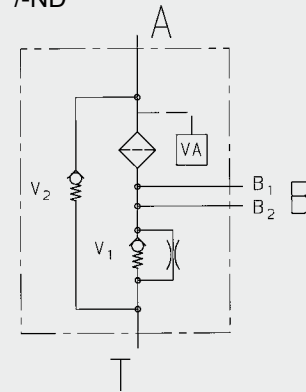

RKM 350

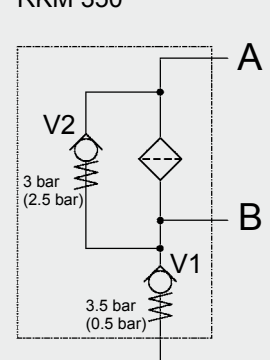

3. FILTER CALCULATION / SIZING

The total pressure drop of a filter at a certain flow rate Q is the sum of the housing Δp and element Δp and is calculated as follows:

$$\Delta p_{\text{total}} = \Delta p_{\text{housing}} + \Delta p_{\text{element}}$$

$$\Delta p_{\text{housing}} = (\text{see point 3.2})$$

$$\Delta p_{\text{element}} = Q \cdot \frac{SK^*}{1000} \cdot \frac{\text{viscosity}}{30}$$

(*see point 3.1)

For ease of calculation, our Filter Sizing Program is available on request free of charge.

NEW: Sizing online at www.hydac.com

3.1 GRADIENT COEFFICIENTS (SK) FOR FILTER ELEMENTS

The gradient coefficients in mbar/(l/min) apply to mineral oils with a kinematic viscosity of 30 mm²/s. The pressure drop changes proportionally to the change in viscosity.

RKM	MM	
	10 μm	15 μm
80	2.70	1.60
100	1.80	1.10
120	1.40	0.90
151	1.00	0.65
201	0.75	0.47
251	0.58	0.36
300	0.62	0.39
350	0.30	0.20
400	0.56	0.35
800	0.44	0.27

3.2 Δp -Q HOUSING GRAPHS BASED ON ISO 3968

The housing graphs apply to mineral oil with a density of 0.86 kg/dm³ and a kinematic viscosity of 30 mm²/s. In this case, the differential pressure changes proportionally to the density.

RKM 80

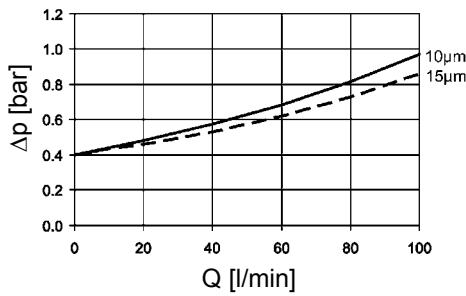

RKM 100

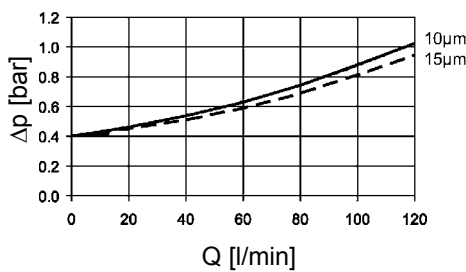

RKM 120

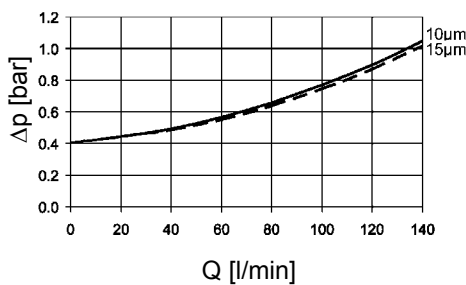

RKM 151

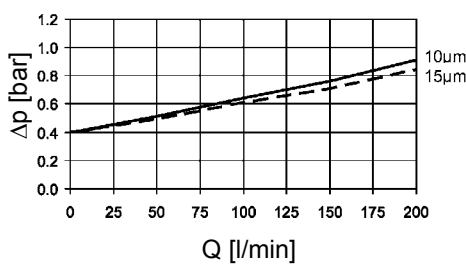

RKM 201

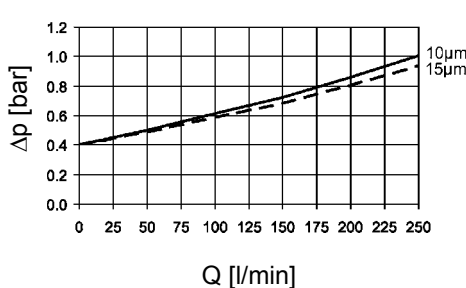

RKM 251

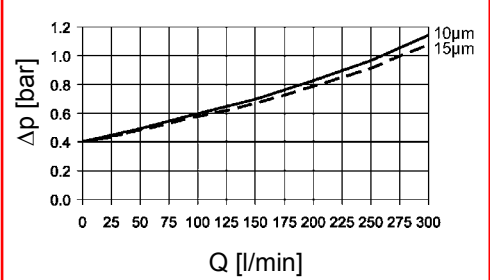

RKM 300

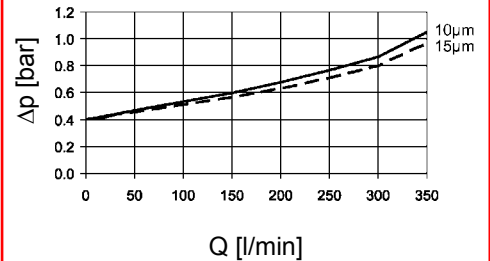

RKM 350

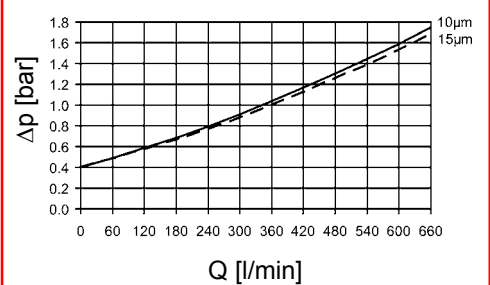

RKM 400

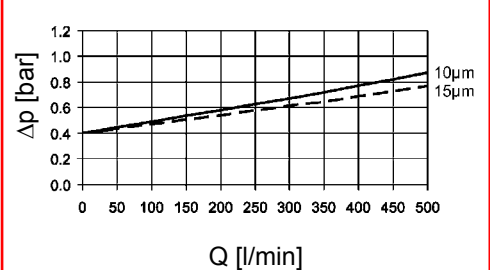

RKM 800

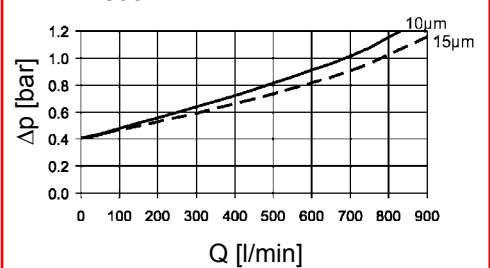

4. DIMENSIONS

RKM 80, 100, 120

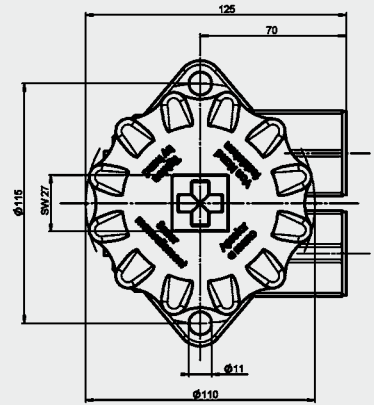
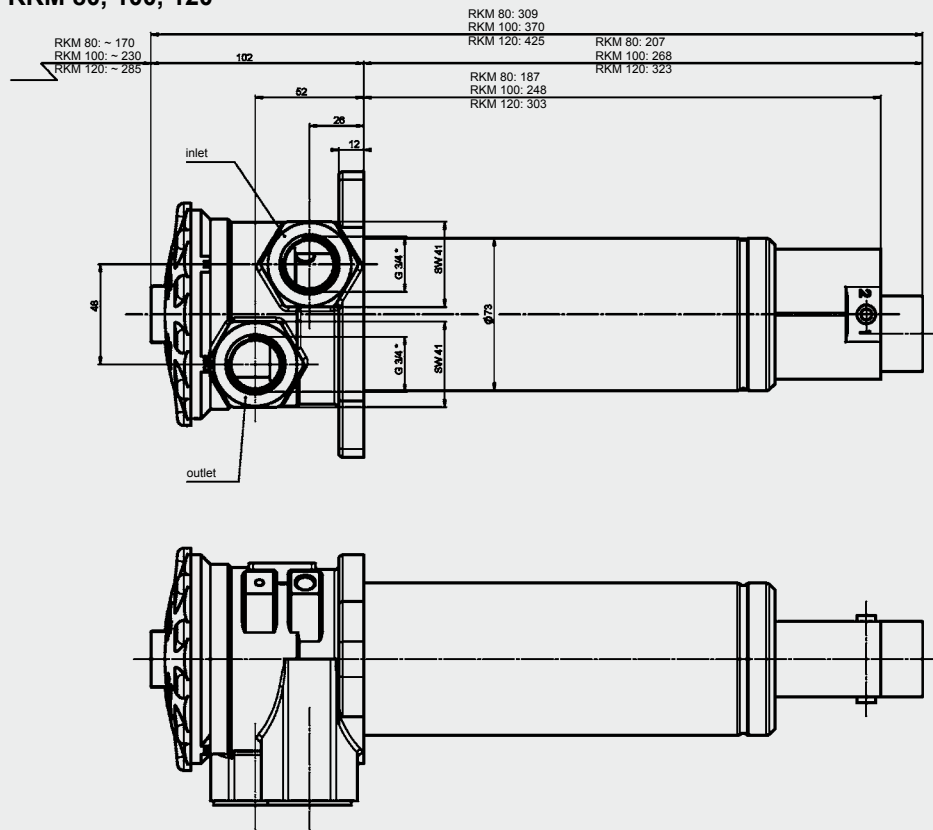

Port sizes

Inlet	G 3/4	G1
Outlet	G 3/4	G1

RKM	Weight incl. element [kg]	Vol. of pressure chamber [l]
80	1.5	0.80
100	1.7	1.00
120	1.9	1.20

RKM 151, 201, 251

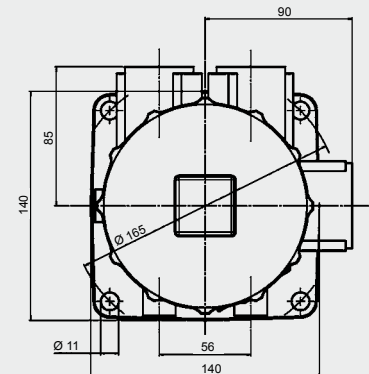
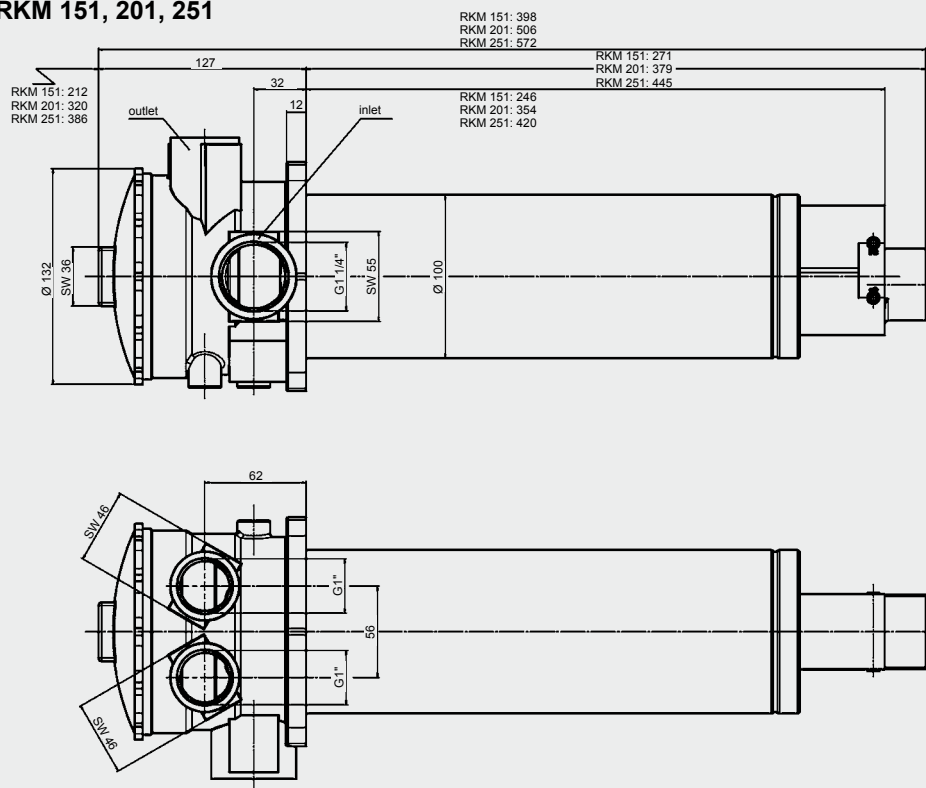

Multi-port version
on request!



RKM	Weight incl. element [kg]	Vol. of pressure chamber [l]
151	3.1	2.20
201	3.7	2.50
251	4.0	3.00

RKM 151, 201, 251 with thermal cooler bypass valve

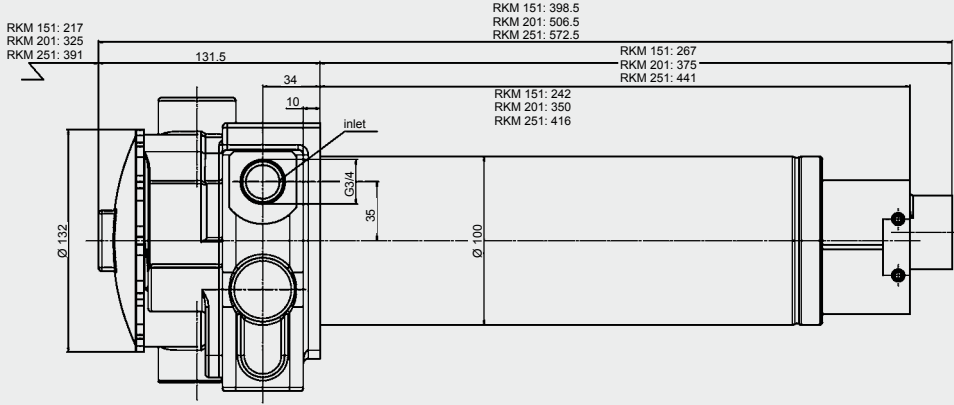
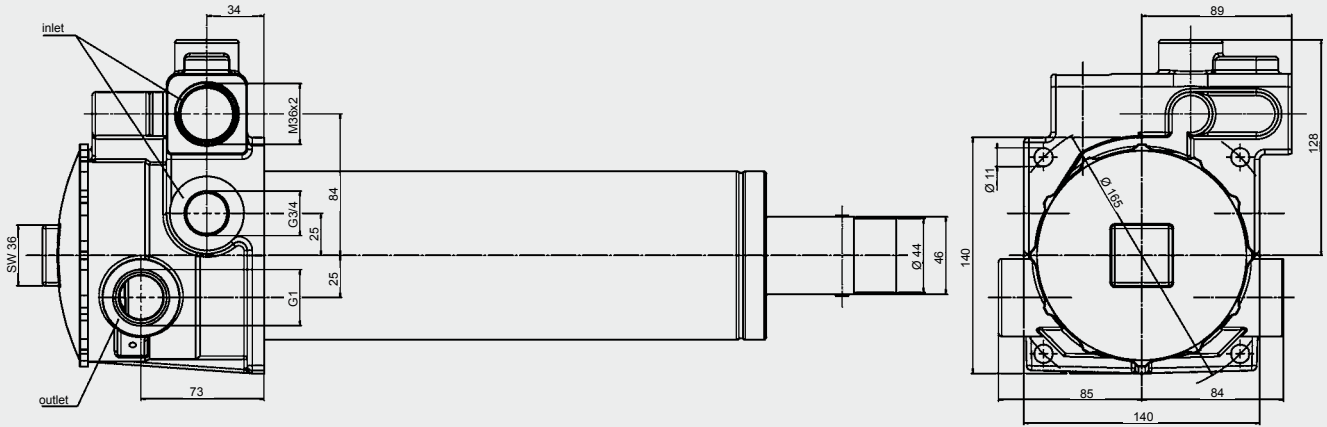

RKM	Weight incl. element [kg]	Vol. of pressure chamber [l]
151	4.6	2.20
201	5.2	2.50
251	5.5	3.00

RKM 300

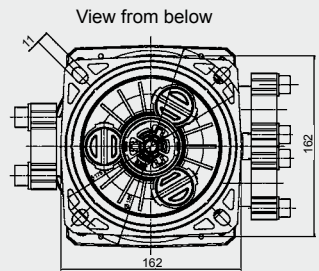
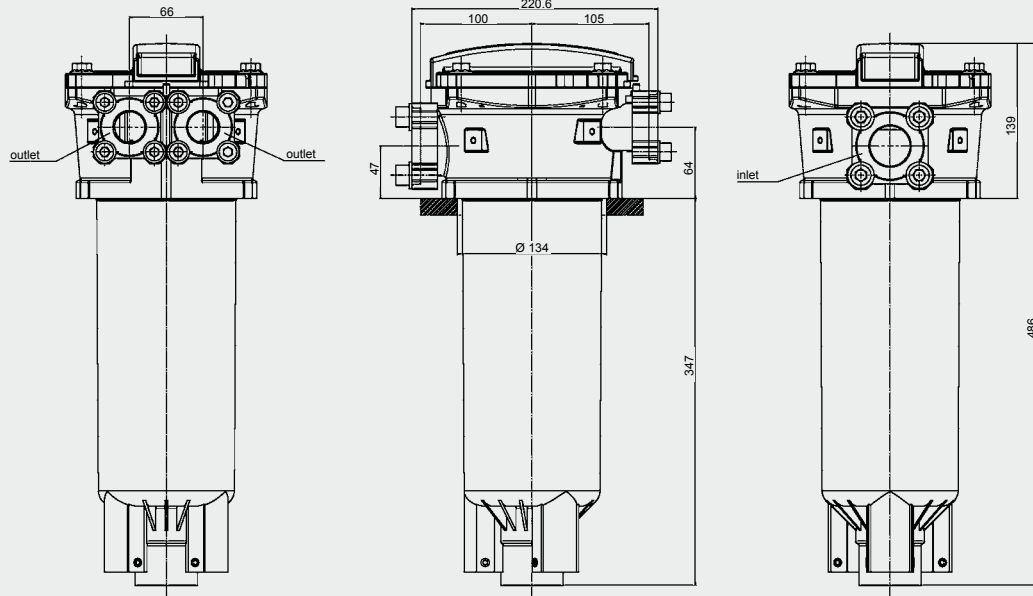

RKM	Weight incl. element [kg]	Vol. of pressure chamber [l]
300	4.6	4.00

RKM 350

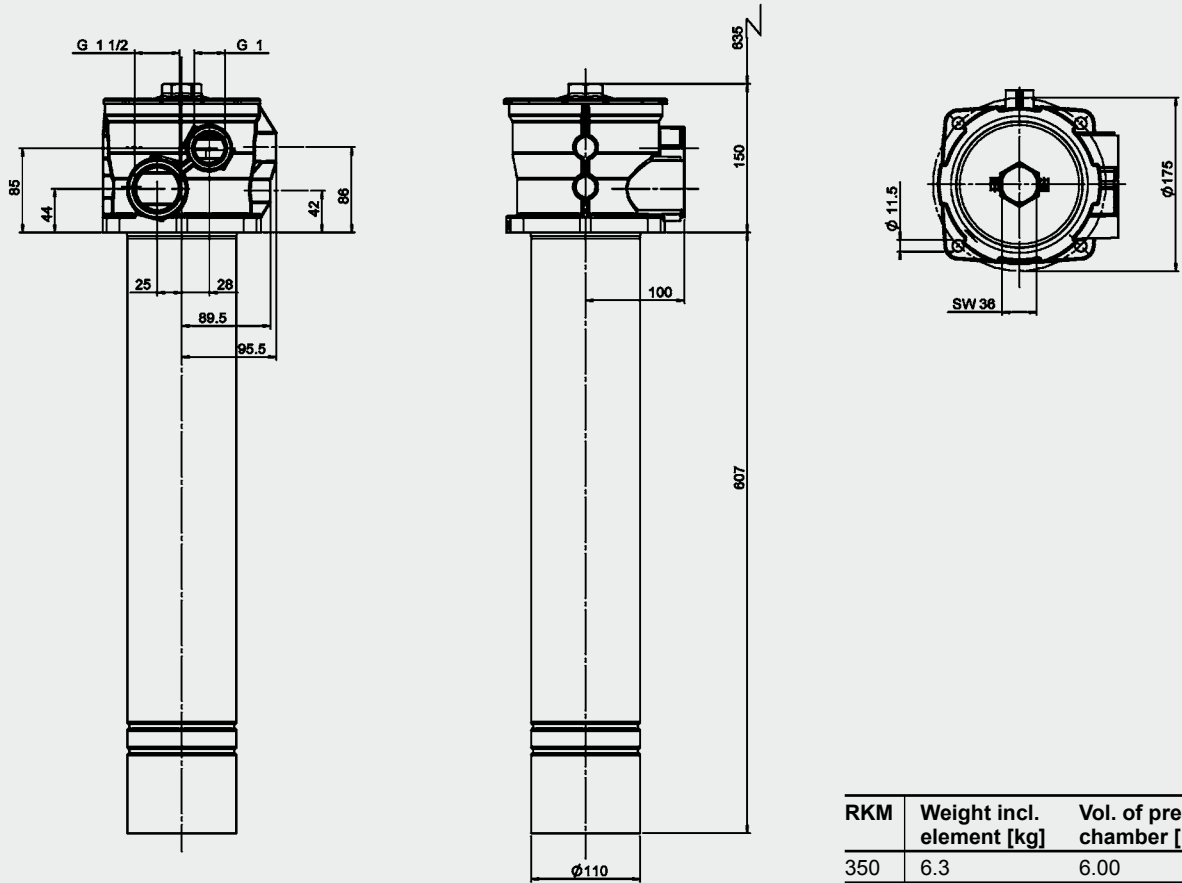

RKM	Weight incl. element [kg]	Vol. of pressure chamber [l]
350	6.3	6.00

RKM 400, 800

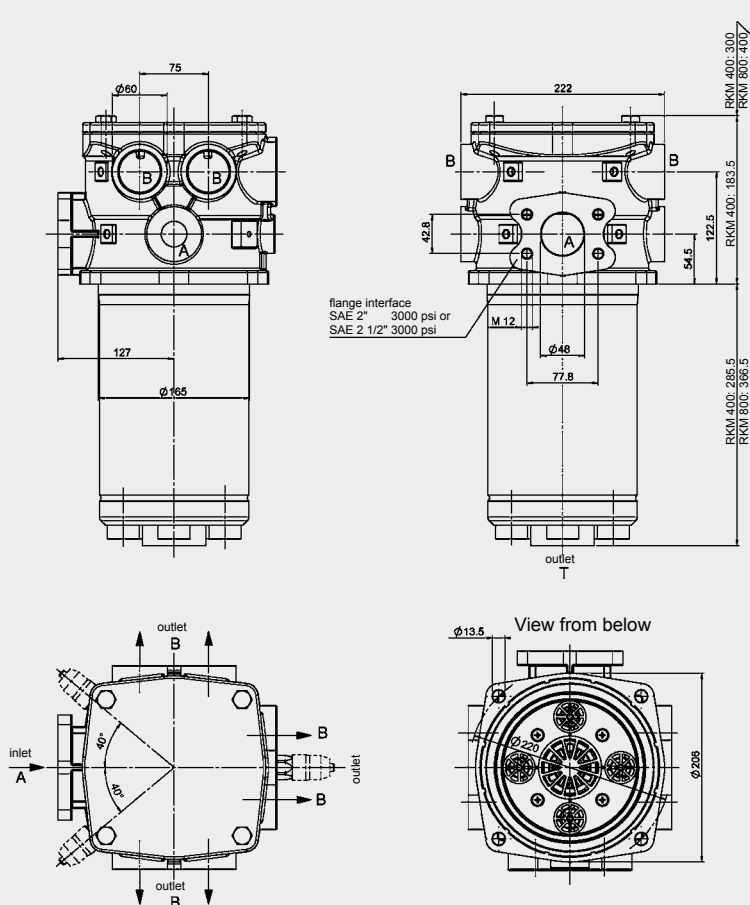

RKM	Weight incl. element [kg]	Vol. of pressure chamber [l]
400	6.5	8.50
800	7.5	10.00

NOTE

The information in this brochure relates to the operating conditions and applications described.

For applications or operating conditions not described, please contact the relevant technical department.

Subject to technical modifications.

HYDAC Filbertechnik GmbH
 Industriegebiet
D-66280 Sulzbach/Saar
 Tel.: 0 68 97 / 509-01
 Fax: 0 68 97 / 509-300
 Internet: www.hydac.com
 E-Mail: filter@hydac.com