



Hydraulic Bladder Accumulator Low Pressure

1. DESCRIPTION

1.1. FUNCTION

Fluids are practically incompressible and cannot therefore store pressure energy.

The compressibility of a gas utilised in hydraulic accumulators for storing fluids. HYDAC bladder accumulators are based on this principle, using nitrogen as the compressible medium.

A bladder accumulator consists of a fluid section and a gas section with the bladder acting as the gas-proof screen. The fluid around the bladder is connected to the hydraulic circuit so that the bladder accumulator draws in fluid when the pressure increases and the gas is compressed. When the pressure drops, the compressed gas expands and forces the stored fluid into the circuit.

HYDAC bladder accumulators can be used in a wide variety of applications, some of which are listed below:

- energy storage
- emergency operation
- force equilibrium
- leakage compensation
- volume compensation
- shock absorption
- vehicle suspension
- pulsation damping

See catalogue section:

- Hydraulic dampers
No. 3.701

1.2. DESIGN

1.2.1 Construction

HYDAC low pressure bladder accumulators consist of a welded pressure vessel, a flexible bladder with gas valve and a hydraulic connection with check valve or a perforated disc.

The table shows the different models which are described in greater detail in the pages that follow:

Designation	Perm. pressure [bar] ²⁾	Volume [l]	Q ¹⁾ [l/s]
SB40- 2.5 ... 50	40	2.5 - 50	7
SB40- 70 ... 220		70 - 220	30
SB35HB- 20 ... 50	35	20 - 50	20
SB16A- 100 ... 450	16	100 - 450	15
SB35A- 100 ... 450	35		
SB16AH- 100 ... 450	16		
SB35AH- 100 ... 450	35		20

¹⁾ Q = max. flow rate of pressure fluid

²⁾ Higher pressures on request

1.2.2 Bladder material

The following elastomers are available as standard:

- NBR (acrylonitrile butadiene rubber, Perbunan),
- IIR (butyl rubber),
- FKM (fluoro rubber, Viton®),
- ECO (ethylene oxide epichlorohydrin rubber).

The material must be selected according to the particular operating fluid and temperature.

When choosing the elastomer, allowances must be made for the fact that the gas can cool down to below the permitted elastomer temperature if there are adverse discharge conditions (high pressure ratio p_2/p_0 , high discharging velocity). This can cause cold cracking in the elastomer.

The gas temperature can be calculated using the HYDAC Accumulator Simulation Program ASP.

1.2.3 Corrosion protection

For operation with chemically aggressive media, the accumulator shell can be supplied with corrosion protection, such as plastic coating on the inside or chemical nickel-plating. If this is insufficient, then stainless steel accumulators must be used.

1.3. MOUNTING POSITION

HYDAC bladder accumulators can be installed vertically, horizontally and at a slant. When installing vertically or at a slant, the oil valve must be at the bottom. On certain applications listed below, particular positions are preferable:

- Energy storage:
vertical,
- Pulsation damping:
any position from horizontal to vertical,
- Maintaining constant pressure:
any position from horizontal to vertical,
- Pressure surge damping:
vertical,
- Volume compensation:
vertical.

If the mounting position is horizontal or at a slant, the effective volume and the maximum permitted flow rate of the operating fluid are reduced.

Bladder accumulators SB16A / SB35A and SB16AH / SB35AH must only be installed vertically with the gas side at the top.

1.4. TYPE OF MOUNTING

For strong vibrations and volumes above 1 litre, we recommend the use of HYDAC accumulator supports or the HYDAC accumulator mounting set.

See catalogue sections:

- Supports for hydraulic accumulators
No. 3.502
- ACCUSET SB
No. 3.503

2. TECHNICAL SPECIFICATIONS

2.1. EXPLANATORY NOTES

2.1.1 Operating pressure

See tables
(may differ from nominal pressure for foreign test certificates)

2.1.2 Nominal volume

See tables

2.1.3 Effective gas volume

See tables,
based on nominal dimensions, this differs slightly from the nominal volume and must be used when calculating the effective volume.

2.1.4 Effective volume

Volume of fluid which is available between the operating pressures p_2 and p_1 .

2.1.5 Max. flow rate of the operating fluid

In order to achieve the max. flow rate given in the tables, the accumulator must be mounted vertically. It must be remembered that the residual fluid volume of approx. 10% of the effective gas volume remains in the accumulator.

2.1.6 Fluids

The following sealing and bladder materials are suitable for the fluids listed below.

Material	Fluids
NBR	Mineral oils (HL, HLP, HFA, HFB, HFC), water
ECO	Mineral oil
IIR	Phosphate ester, water
FKM	Chlorinated hydrocarbons, petrol

2.1.7 Permitted operating temperature

The permitted operating temperatures are dependent on the application limits of the metallic materials and the bladders.

The standard valve bodies, gas valves and accumulator shells are suitable for temperatures from -10 °C ... $+80\text{ °C}$.

Outside these temperatures, special material combinations must be used.

The following table shows the correlation between bladder material and application temperature.

Material	Temperature ranges
NBR20	-15 °C ... $+80\text{ °C}$
NBR21	-50 °C ... $+80\text{ °C}$
NBR22	-30 °C ... $+80\text{ °C}$
ECO	-30 °C ... $+120\text{ °C}$
IIR	-40 °C ... $+100\text{ °C}$
FKM	-10 °C ... $+150\text{ °C}$

2.1.8 Gas charging

Always only charge with nitrogen class 4.5, filtered to $< 3\text{ }\mu\text{m}$.

If other gases are to be used, please contact HYDAC for advice.

Hydraulic accumulators must only be charged with nitrogen.

Never use other gases.

Risk of explosion!

2.1.9 Limits for gas pre-charge pressure

$$p_0 \leq 0.9 \cdot p_1$$

with a permitted pressure ratio of:

$$p_2 : p_0 \leq 4 : 1$$

p_2 = max. operating pressure

p_0 = gas pre-charge pressure

2.1.10 Certificate codes

Canada	S1 ²⁾
China	A9
EU member states	U ¹⁾
Japan	P
Switzerland	U
USA	S
Others on request	

¹⁾ Alternative certificates possible

²⁾ Approval required in the individual provinces

On no account must any welding, soldering or mechanical work be carried out on the accumulator shell. After the hydraulic line has been connected it must be completely vented.

Work on systems with hydraulic accumulators (repairs, connecting pressure gauges etc) must only be carried out once the pressure and the fluid have been released.

Please read the operating manual!

No. 3.201.CE

Note:

Application examples, accumulator sizing and extracts from approvals regulations on hydraulic accumulators can be found in the following catalogue section:

- Accumulators
No. 3.000

2.2. MODEL CODE

(also order example)

SB35 A - 100 F 7 / 112 U - 35 A

Series

Type

- H = high flow
- N = increased flow, standard oil valve dimensions
- A = shock absorber
- B = bladder top-repairable
- Combinations possible, e.g. HB - High flow with a top-repairable bladder
- no details = standard

Nominal volume [l]

Fluid connection

- A = standard connection, thread with internal seal face
- F = flange connection
- C = valve mounting with screws on underside
- E = sealing surfaces on front interface (e.g. on thread M50x1.5 - valve)
- G = male thread
- S = special connection, to customer specification

Gas side

- 1 = standard model
- 2 = back-up model
- 3 = gas valve 7/8-14UNF with M8 female thread
- 4 = 5/8" gas valve
- 5 = gas valve M50x1.5 in accumulators smaller than 50 l
- 6 = 7/8-14UNF gas valve
- 7 = M28x1.5 gas valve
- 8 = M16x1.5 gas valve
- 9 = special gas valve, to customer specification

Material code ¹⁾

- Standard model = 112 for mineral oil
- Depending on operating fluid
- Others on request

Fluid connection

- 1 = carbon steel
- 2 = high tensile steel
- 3 = stainless steel ³⁾
- 6 = low temperature steel

Accumulator body

- 0 = plastic coated (internally)
- 1 = carbon steel
- 2 = chemically nickel-plated (internal coating)
- 4 = stainless steel ³⁾
- 6 = low temperature steel

Accumulator bladder ^{2) 4)}

- 2 = NBR20
- 3 = ECO
- 4 = IIR (butyl)
- 5 = NBR21 (low temperature)
- 6 = FKM
- 7 = other
- 9 = NBR22

Certification code

- U = PED 97/23/EC

Permitted operating pressure [bar]

Connection

Thread, codes for fluid connections: A, C, E, G

- A = Thread to ISO 228 (BSP)
- B = Thread to DIN 13 or ISO 965/1 (metric)
- C = Thread to ANSI B1.1 (UN..-2B seal SAE J 514)
- D = Thread to ANSI B1.20.1 (NPT)
- S = special thread, to customer specification

Flange, codes for fluid connection: F

- A = EN 1092-1 welding neck flange
- B = flange ASME B16.5
- C = SAE flange 3000 psi
- D = SAE flange 6000 psi
- S = special flange, to customer specification

Required gas pre-charge pressure must be stated separately!

¹⁾ Not all combinations are possible

²⁾ When ordering spare bladders, please state smallest bladder connection port size at gas charging end

³⁾ Depending on type and pressure rating

⁴⁾ Standard materials, all other materials on request

3. LOW PRESSURE ACCUMULATORS

3.1 STANDARD BLADDER ACCUMULATORS SB40-2.5 ... 50

3.1.1 Design

HYDAC standard low pressure accumulators consist of:

- A welded pressure vessel which can be treated with various types of corrosion protection for chemically aggressive fluids, or can be supplied in stainless steel.
- A bladder with gas valve. The bladders are available in the elastomers listed under point 2.1.
- A hydraulic connector with a perforated disc which is held in place with retaining ring.

3.1.2 Dimensions SB40-2.5 ... 50

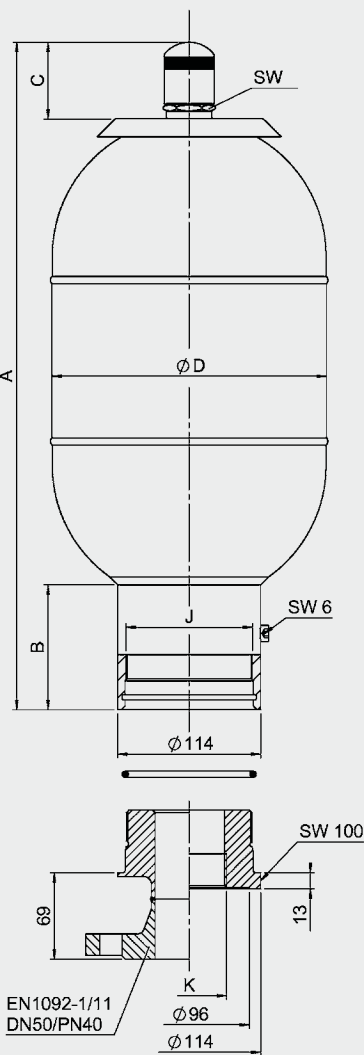

3.1.3 Spare parts SB40-2.5 ... 50

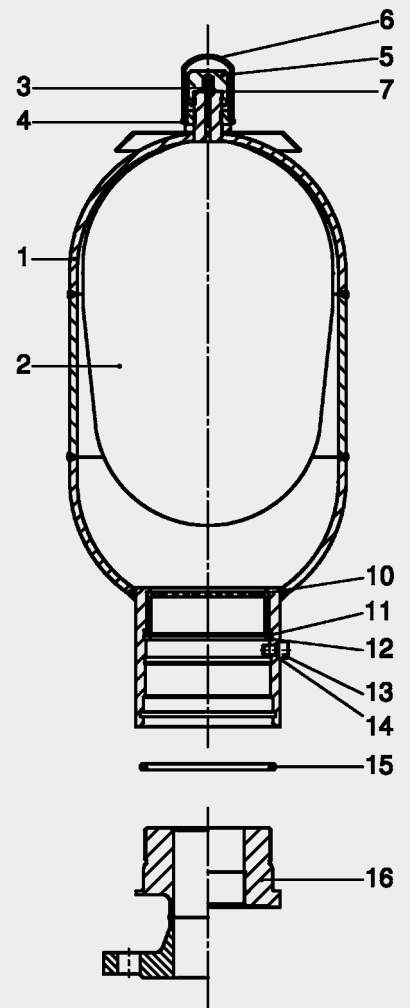

SB40-2.5 ... 50

Permitted operating pressure 40 bar (PED 97/23/EC)

Nominal volume [l]	Eff. gas volume [l]	Wt. [kg]	A [mm]	B [mm]	C [mm]
2.5	2.5	9	541	122	68
5	5.0	13	891		
10	8.7	14	533	106	
20	18.0	23	843		
32	33.5	38	1363		
50	48.6	52	1875		

Nom. vol. [l]	Ø D [mm]	J Thread ISO DIN 13	K* Thread ISO 228	SW [mm]	Q ¹⁾ [l/s]	
2.5	108	M100x2	G 2	36	7	
5						
10	219					68 ²⁾
20						
32						
50						

* Item 16 must be ordered separately

¹⁾ Q = max. flow rate of operating fluid (at approx. 0.5 bar pressure drop via adapter)

²⁾ Lock nut

Description	Item
Bladder kit¹⁾	
consisting of:	
Bladder	2
Gas valve insert*	3
Lock nut	4
Seal cap	5
Valve protection cap	6
O-ring	7
Seal kit	
consisting of:	
O-ring	7
Vent screw	13
Seal ring	14
O-ring	15
Repair kit¹⁾	
consisting of:	
Bladder kit (see above)	
Seal kit (see above)	
Hydraulic connector assembly	
consisting of:	
Perforated disc	10
Anti-extrusion ring	11
Retaining ring	12
Vent screw	13
Seal ring	14
O-ring	15

* available separately

¹⁾ When ordering spare bladders, please state smallest bladder connection port size at gas charging end.

Item 1 not available as a spare part.

3.2. BLADDER ACCUMULATOR SB40-70 ... 220

3.2.1 Design

HYDAC low pressure accumulators, type SB40-70 ... 220 consist of:

- A welded pressure vessel which is compact and yet suitable for high flow rates and large volumes. The pressure vessel is manufactured in carbon steel or in stainless steel.
- An accumulator bladder with gas valve.
- A hydraulic connector with check valve.

3.2.2 Dimensions SB40-70 ... 220

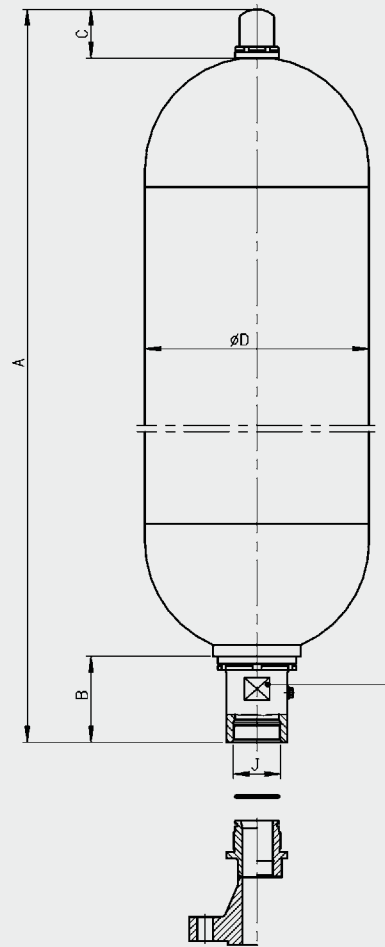

SB40-70 ... 220

Permitted operating pressure 40 bar (PED 97/23/EC)

Nominal volume [l]	Eff. gas volume [l]	Wt. [kg]	A max. [mm]	B [mm]
70	64	94	1199	137
100	111	113	1629	
130	133	133	1879	
190	192	169	2086	
220	220	193	2330	

Nominal volume [l]	C [mm]	Ø D [mm]	J Thread ISO 228	Q ¹⁾ [l/s]
70	78	356	G 2 1/2	30
100				
130				
190				
220		407		

¹⁾ Q = max. flow rate of operating fluid

3.2.3 Spare parts SB40-70 ... 220

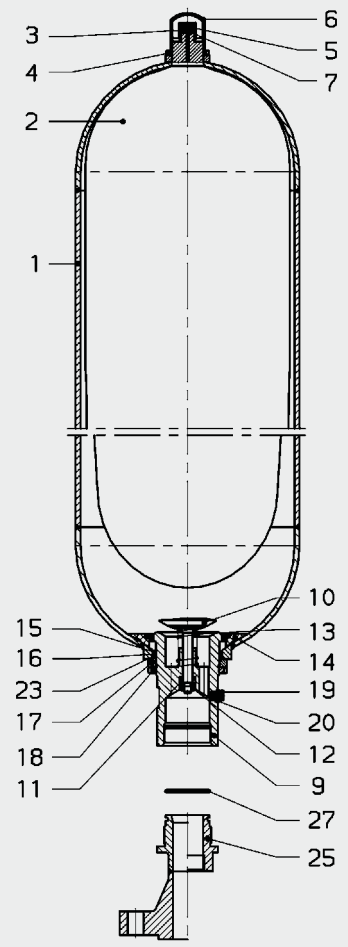

Description

Description	Item
Bladder kit ¹⁾	
consisting of:	
Bladder	2
Gas valve insert*	3
Lock nut	4
Seal cap	5
Valve protection cap	6
O-ring	7

Seal kit	
consisting of:	
O-ring	7
Washer	15
O-ring	16
Vent screw	19
Support ring	23
O-ring	27

Repair kit ¹⁾	
consisting of:	
Seal kit (see above)	
Bladder kit (see above)	

Anti-extrusion ring 14

Oil valve assembly	
consisting of:	
Valve assembly (items 9-13)	9
Anti-extrusion ring	14
Washer	15
O-ring	16
Spacer	17
Lock nut	18
Vent screw	19
Support ring	23

* available separately

¹⁾ When ordering spare bladders, please state smallest bladder connection port size at gas charging end.

Item 1 not available as a spare part.

Item 19 for NBR/Carbon steel

Seal ring (Item 20) included

3.3. LOW PRESSURE ACCUMULATORS SB16/35A AND SB16/35AH

3.3.1 Design

HYDAC low pressure bladder accumulators for large volumes, type SB35A and SB16A are in a weld construction in carbon steel or stainless steel.

The hydraulic outlet is covered by a perforated disc which prevents the flexible bladder extruding from the shell. The bladder is top-repairable.

The bladder accumulators have a connection assembly suitable for max. 15 l/s (SB16/35A) or max. 70 l/s (SB16/35AH) at a Δp of 2 bar.

3.3.2 Dimensions SB16/35A, SB16/35AH

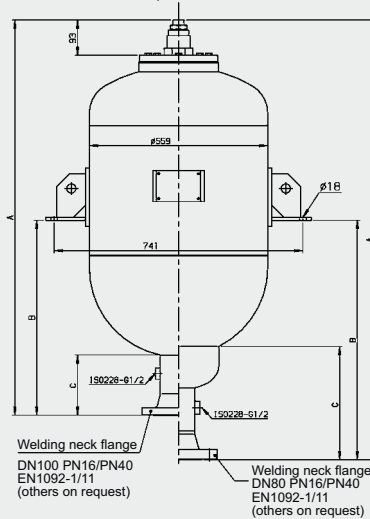

SB16/35A

Permitted operating pressure 16/35 bar (PED 97/23/EC)

Nominal volume [l]	Eff. gas volume [l]	Weight [kg]		A (approx.) [mm]	
		SB16A	SB35A	SB16A	SB35A
100	99	84	144	880	880
150	143	101	161	1070	1080
200	187	122	223	1310	1320
300	278	155	288	1710	1720
375	392	191	326	2230	2240
450	480	237	386	2325	2635

Nominal volume [l]	B (approx.) [mm]		C (approx.) [mm]		DN*
	SB16A	SB35A	SB16A	SB35A	
100	390	403	185	198	100
150	490	503			
200	685	698			
300	975	988			
375	1250	1263			
450	1465	1478			

SB16/35AH

Permitted operating pressure 16/35 bar (PED 97/23/EC)

Nominal volume [l]	Eff. gas volume [l]	Weight [kg]		A (approx.) [mm]	
		SB16AH	SB35AH	SB16AH	SB35AH
100	99	93	153	957	965
150	143	110	170	1157	1165
200	187	131	230	1417	1425
300	278	164	297	1865	1873
375	392	200	335	2307	2315
450	480	246	395	2702	2710

Nominal volume [l]	B (approx.) [mm]		C (approx.) [mm]		DN*
	SB16AH	SB35AH	SB16AH	SB35AH	
100	457	465	245	254	80
150	557	565			
200	842	850			
300	1092	1100			
375	1342	1350			
450	1542	1550			

* to EN1092-1/11 / PN16 or PN40
Others on request

3.3.3 Spare parts SB16/35A, SB16/35AH

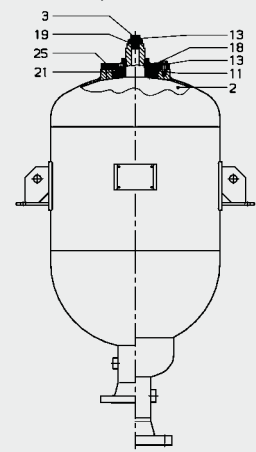

Description	Item
Bladder	2
Lock nut	3
O-ring	11
Seal ring	13
Vent screw	18
O-ring	19
Retaining ring	21
O-ring	25

3.4. HIGH FLOW BLADDER ACCUMULATORS SB35HB

3.4.1 Design

HYDAC high flow bladder accumulators type SB35HB are high performance accumulators for flow rates of up to 20 l/s at 2 bar Δp .

They consist of a pressure vessel in a weld construction and a flexible bladder with gas valve.

The pressure vessel contains a fixed perforated disc, permitting a high flow rate through its large free cross-section. For use with chemically aggressive fluids, the shell can be manufactured in stainless steel. See point 2.1 for bladder materials.

3.4.2 Dimensions SB35HB

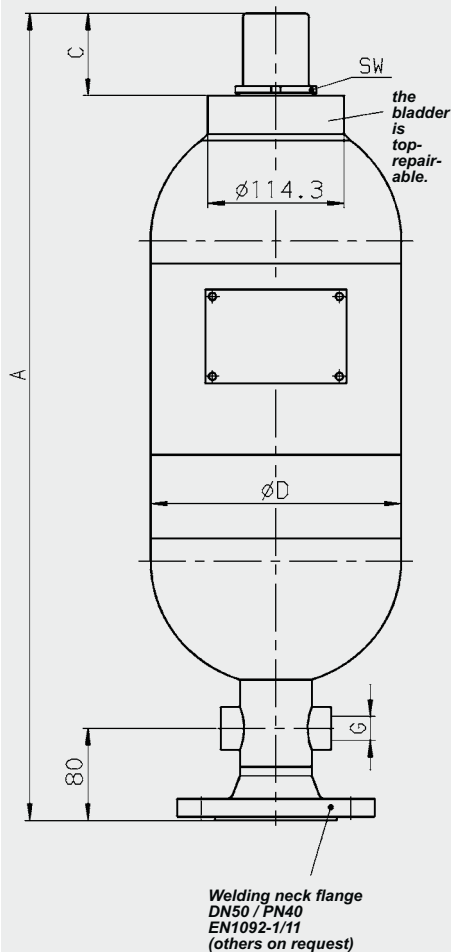

SB35HB

Permitted operating pressure 35 bar (PED 97/23/EC)

Nominal volume [l]	Eff. gas volume [l]	Weight [kg]	A max. [mm]
20	19.8	43	1081
32	35.0	56	1591
50	50.0	69	2091

Nominal volume [l]	C [mm]	Ø D [mm]	J Thread ISO 228	SW [mm]	Q ¹⁾ [l/s]
20	63	219	G 1/2	36	20
32				Ø68 ²⁾	
50	78				

¹⁾ Q = max. flow rate of pressure fluid

²⁾ Lock nut

3.4.3 Spare parts SB35HB

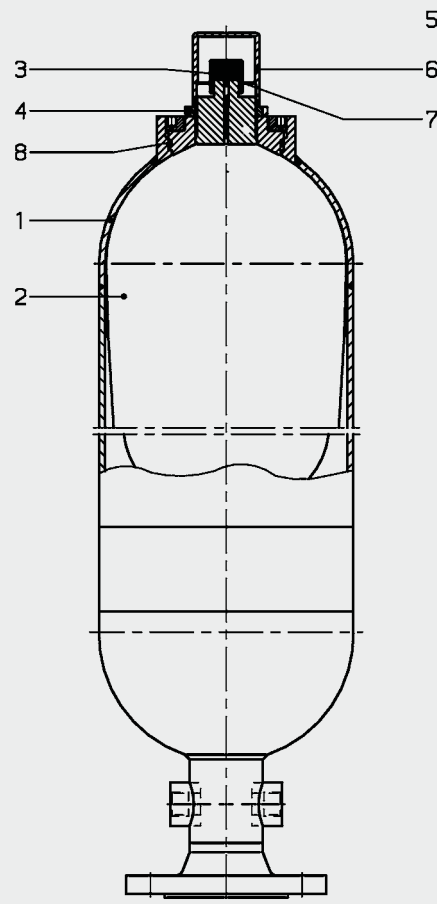

Description

Item

Bladder kit¹⁾
consisting of:

Bladder	2
Gas valve insert*	3
Lock nut	4
Seal cap	5
Valve protection cap	6
O-ring	7

Seal kit

consisting of:

Gas valve insert*	3
O-ring	7
O-ring	8

Repair kit¹⁾

consisting of:

Bladder kit (see above)	
Seal kit (see above)	

* available separately

¹⁾ When ordering spare bladders, please state smallest bladder connection port size at gas charging end
Item 1 not available as a spare part.

4. NOTE

The information in this brochure relates to the operating conditions and applications described.

For applications and operating conditions not described, please contact the relevant technical department.

Subject to technical modifications.

HYDAC Technology GmbH

Industriegebiet

D-66280 Sulzbach/Saar

Tel.: 0 68 97 / 509 - 01

Fax: 0 68 97 / 509 - 464

Internet: www.hydac.com

E-Mail: speichertechnik@hydac.com

