



Hydraulic Bladder Accumulator Standard

1. DESCRIPTION

1.1. FUNCTION

Fluids are practically incompressible and cannot therefore store pressure energy.

The compressibility of a gas is utilised in hydraulic accumulators for storing fluids. HYDAC bladder accumulators are based on this principle, using nitrogen as the compressible medium.

A bladder accumulator consists of a fluid section and a gas section with the bladder acting as the gas-proof screen.

The fluid around the bladder is connected to the hydraulic circuit so that the bladder accumulator draws in fluid when the pressure increases and the gas is compressed.

When the pressure drops, the compressed gas expands and forces the stored fluid into the circuit.

HYDAC bladder accumulators can be used in a wide variety of applications, some of which are listed below:

- energy storage
- emergency operation
- force equilibrium
- leakage compensation
- volume compensation
- shock absorption
- vehicle suspension
- pulsation damping

See catalogue section:

- Hydraulic Dampers
No. 3.701

1.2. DESIGN

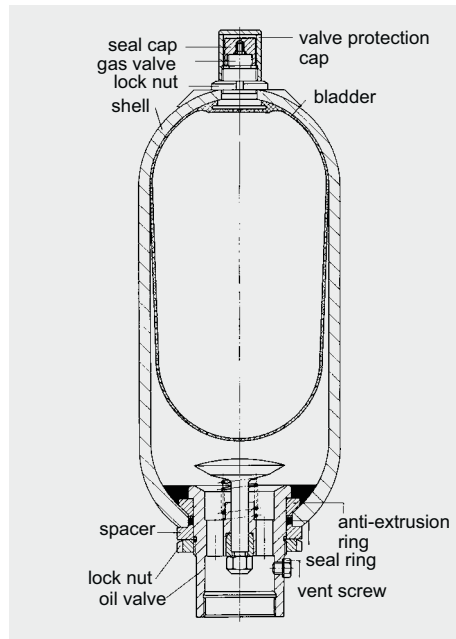

1.2.1 Design

● Standard Bladder Accumulator SB330/400/500/550

HYDAC standard bladder accumulators consist of the pressure vessel, the flexible bladder with gas valve and the hydraulic connection with check valve. The pressure vessel is seamless and manufactured from high tensile steel.

● Bladder accumulator SB330N

The flow optimised design of the standard oil valve enables the maximum possible operating fluid flow rate to increase to 25 l/s on this accumulator type.

● High Flow bladder accumulator SB330H

HYDAC high flow bladder accumulators, type SB330H, are high performance accumulators with a flow rate of up to 30 l/s. The fluid connection is enlarged to allow higher flow rates.

1.2.2 Bladder material

The following elastomers are available as standard:

- NBR (acrylonitrile butadiene rubber, Perbunan),
- IIR (butyl rubber),
- FKM (fluoro rubber, Viton®),
- ECO (ethylene oxide epichlorohydrin rubber).

The material must be selected according to the particular operating fluid and temperature.

When choosing the elastomer, allowances must be made for the fact that the gas can cool down to below the permitted elastomer temperature if there are adverse discharge conditions (high pressure ratio p_2/p_0 , high discharging velocity). This can cause cold cracking in the elastomer.

The gas temperature can be calculated using the HYDAC Accumulator Simulation Program ASP.

1.2.3 Corrosion protection

For operation with chemically aggressive media, the accumulator shell can be supplied with corrosion protection, such as plastic coating on the inside or chemical nickel-plating. If this is insufficient, then stainless steel accumulators must be used.

1.3. MOUNTING POSITION

HYDAC bladder accumulators can be installed vertically, horizontally and at a slant. When installing vertically or at a slant, the oil valve must be at the bottom. On certain applications listed below, particular positions are preferable:

- Energy storage: vertical,
- Pulsation damping: any position from horizontal to vertical,
- Maintaining constant pressure: any position from horizontal to vertical,
- Volume compensation: vertical.

If the mounting position is horizontal or at a slant, the effective volume and the maximum permitted flow rate of the operating fluid are reduced.

1.4. TYPE OF MOUNTING

By using an appropriate adapter, HYDAC accumulators, up to size 1 l, can be mounted directly inline.

For strong vibrations and volumes above 1 l, we recommend the use of HYDAC accumulator supports or the HYDAC accumulator mounting set.

See catalogue sections:

- Supports for Hydraulic Accumulators No. 3.502
- ACCUSET SB No. 3.503

2. TECHNICAL SPECIFICATIONS

2.1. EXPLANATORY NOTES

2.1.1 Operating pressure

See tables
(may differ from nominal pressure for foreign test certificates)

2.1.2 Nominal volume

See tables

2.1.3 Effective gas volume

See tables
based on nominal dimensions, this differs slightly from the nominal volume and must be used when calculating the effective volume.

2.1.4 Effective volume

Volume of fluid which is available between the operating pressures p_2 and p_1 .

2.1.5 Max. flow rate of operating fluid

In order to achieve the max. flow rate given in the tables, the accumulator must be mounted vertically. It must be remembered that a residual fluid volume of approx. 10% of the effective gas volume remains in the accumulator.

2.1.6 Fluids

The following sealing and bladder materials are suitable for the fluids listed below.

Material	Fluids
NBR20	Mineral oils (HL, HLP, HFA, HFB, HFC), water
ECO	Mineral oil
IIR	Phosphate ester
FKM	Chlorinated hydrocarbons, petrol

2.1.7 Permitted operating temperature

The permitted operating temperatures are dependent on the application limits of the metallic materials and the bladders.

The standard valve bodies, gas valves and accumulator shells are suitable for temperatures from -10 °C ... $+80\text{ °C}$.

Outside these temperatures, special material combinations must be used. The following table shows the correlation between bladder material and application temperature.

Material	Temperature ranges
NBR20	-15 °C ... $+80\text{ °C}$
NBR21	-50 °C ... $+80\text{ °C}$
NBR22	-30 °C ... $+80\text{ °C}$
ECO	-30 °C ... $+120\text{ °C}$
IIR	-40 °C ... $+100\text{ °C}$
FKM	-10 °C ... $+150\text{ °C}$

2.1.8 Gas charging

Always only charge with nitrogen class 4.5, filtered to $< 3\text{ }\mu\text{m}$.

If other gases are to be used, please contact HYDAC for advice.

Hydraulic accumulators must only be charged with nitrogen.

Never use other gases.

Risk of explosion!

2.1.9 Limits for gas pre-charge pressure

$$p_0 \leq 0.9 \cdot p_1$$

with a permitted pressure ratio of:

$$p_2 : p_0 \leq 4 : 1$$

p_2 = max. operating pressure

p_0 = gas pre-charge pressure

2.1.10 Certificate codes

China	A9
EU member states	U ¹⁾
Japan	P
Canada	S1 ²⁾
Switzerland	U
USA	S

others on request

¹⁾ Alternative certificates possible

²⁾ Approval required in the individual provinces

On no account must any welding, soldering or mechanical work be carried out on the accumulator shell. After the hydraulic line has been connected it must be completely vented.

Work on systems with hydraulic accumulators (repairs, connecting pressure gauges etc) must only be carried out once the pressure and the fluid have been released.

Please read the operating manual!
No. 3.201.CE

Note:

Application examples, accumulator sizing and extracts from approvals regulations on hydraulic accumulators can be found in the following catalogue section:

- Accumulators No. 3.000

2.2. MODEL CODE

(also order example)

SB330 H - 32 A 1 / 112 U - 330 A 050

Series

Type

- H = high flow
 - N = increased flow, standard oil valve dimensions
 - A = shock absorber
 - P = pulsation damper
 - S = suction flow stabiliser
 - B = bladder top-repairable
- Combinations possible, e.g. HB - High flow with a top-repairable bladder
 PH - pulsation damper with high flow rate.
 No details = standard

Nominal volume [l]

Fluid connection

- A = standard connection, thread with internal seal face
- F = flange connection
- C = valve mounting with screws on underside
- E = sealing surfaces on front interface (e.g. on thread M50x1.5 - valve)
- G = male thread
- S = special connection, to customer specification

Gas side

- 1 = standard model ⁴⁾
- 2 = back-up model
- 3 = gas valve 7/8-14UNF with M8 female thread
- 4 = 5/8" gas valve
- 5 = gas valve M50x1.5 in accumulators smaller than 50 l
- 6 = 7/8-14UNF gas valve
- 7 = M28x1.5 gas valve
- 8 = M16x1.5 gas valve
- 9 = special gas valve, to customer specification

Material code ¹⁾

Standard model = 112 for mineral oil
 Depending on operating fluid
 others on request

Fluid connection

- 1 = carbon steel
- 2 = high tensile steel
- 3 = stainless steel ³⁾
- 6 = low temperature steel

Accumulator shell

- 0 = plastic coated (internally)
- 1 = carbon steel
- 2 = chemically nickel-plated (internal coating)
- 4 = stainless steel ³⁾
- 6 = low temperature steel

Accumulator bladder ²⁾

- 2 = NBR20
- 3 = ECO
- 4 = IIR (butyl)
- 5 = NBR21 (low temperature)
- 6 = FKM
- 7 = other
- 9 = NBR22

Certification code

U = PED 97/23/EC

Permitted operating pressure [bar]

Connection

Thread, codes for fluid connections: A, C, E, G
 A = Thread to ISO 228 (BSP)
 B = Thread to DIN 13 or ISO 965/1 (metric)
 C = Thread to ANSI B1.1 (UN..-2B seal SAE J 514)
 D = Thread to ANSI B1.20.1 (NPT)
 S = special thread, to customer specification

Flange, codes for fluid connection: F

- A = DIN flange
- B = flange ANSI B16.5
- C = SAE flange 3000 psi
- D = SAE flange 6000 psi
- S = special flange, to customer specification

Pre-charge pressure p_0 [bar] at 20 °C must be stated separately, if required!

¹⁾ Not all combinations are possible
²⁾ When ordering spare bladders, please state smallest bladder connection port size
³⁾ Depending on type and pressure rating
⁴⁾ Gas valve type in SB < 50 l = 7/8 - 14 UNF, in SB ≥ 50 l = M50x1.5

3. DIMENSIONS AND SPARE PARTS

3.1. DIMENSIONS

Nominal volumes [l]	Valve	Max. operating pressure (PED 97/23/EC) [bar]	Effective gas volume [l]	Weight [kg]	A max.	B	C	Ø D max.	J thread	Ø E	SW	Q ¹⁾	
					[mm]	[mm]	[mm]	[mm]	ISO 228	[mm]	[mm]	[l/s]	
0.5	standard	400	0.5	2.8	270	57	33.5	95.5	G 3/4	50	32	4	
1		330	1.0	4.5	302			118					
		550		8.5	334	68	121	G 1	45				
2.5		330	2.4	10	531	63	58	118	G 1 1/4	67	50		10
		550	2.5	13.5	539	68			121		G 1		45
4		330	3.7	11.5	419	63		173	G 1 1/4	50	10		
		400		15.5									
5		550	4.9	23	867	68		121	G 1	45	4		
6		330	5.7	15	531	63		173	G 1 1/4	50	10		
10 ²⁾		330	9.3	25	728								
10	standard	330	9.3	31.5	568	103		58	229	G 2	103	70	15
	N			25									
	H		9	34.5	603	138			G 2 1/2	125	90	30	
	standard		400	9.3	37.5	572	103		233	G 2	100	70	15
13	standard	330	12	43	660	103	58	229	G 2	100	70	15	
	N			25									
	H		46	695	138	G 2 1/2		125	90	30			
	standard		400	8.8	41	585		77	68	241	G 2	100	70
20	standard	330	18.4	50.5	896	103	58	229	G 2	100	70	15	
	N			25									
	H		17.5	53.5	931	138		G 2 1/2	125	90	30		
	standard		400	18.4	63.5	896		103	233	G 2	100	70	15
24	standard	330	23.6	69.0	1062	103	58	229	G 2	100	70	15	
	N			25									
	H		24	72	1097	138		G 2 1/2	125	90	30		
	standard		400	17	75.5	901		77	68	241	G 2	100	70
32	standard	330	33.9	87	1411	103	58	229	G 2	100	70	15	
	N			25									
	H		32.5	90	1446	138		G 2 1/2	125	90	30		
	standard		400	33.9	104.5	1411		103	233	G 2	100	70	15
50	standard	330	47.5	127	1446	77	68	241	G 2	100	75	15	
	N			25									
	H		117.5	1931	103	229		G 2	100	70	15		
	standard		400	120.5	1966	138		68	241	G 2 1/2	125	90	30
60	standard	330	60	182	1156	138	68	356	G 2 1/2	125	90	30	
				80	221								1406
				100	255								1656
				130	305								1976
				160	396								2006
				200	485								2306

Dimensions

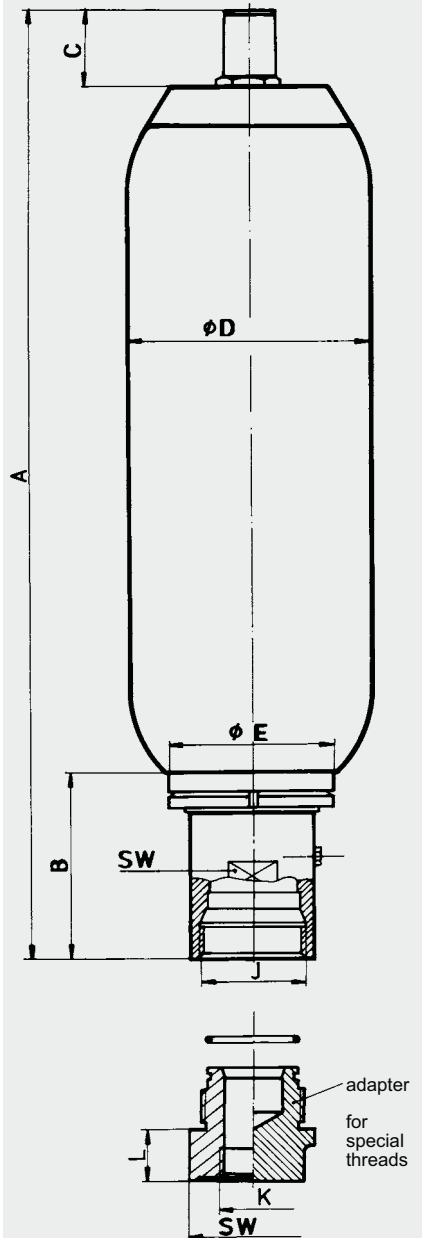

¹⁾ Q = max. flow rate of pressure fluid
²⁾ slimline version, for confined spaces

3.2. SPARE PARTS

SB330/400/440/500/550
SB330H / SB330N

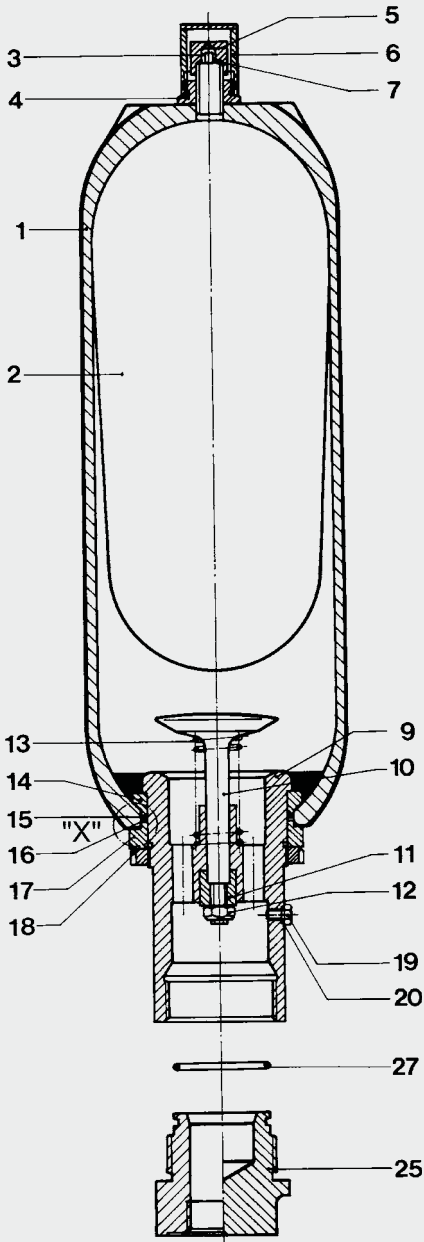

Detail "X"

SB330/400 – 0.5 ... 6 l

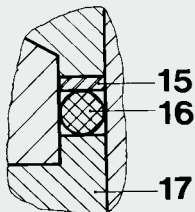

SB330/400/500 – 10 ... 200 l and
SB330H – 10 ... 200 l
SB550 – 1 ... 5 l

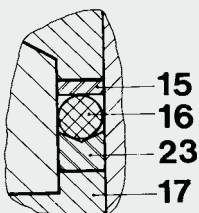

Description	Item
Bladder kit	
consisting of:	
Bladder	2
Gas valve insert*	3
Lock nut	4
Seal cap	5
Valve protection cap	6
O-ring	7
Seal kit	
consisting of:	
O-ring	7
Washer	15
O-ring	16
Vent screw	19
Support ring	23
O-ring	27
Repair kit ¹⁾	
consisting of:	
Bladder kit (see above)	
Seal kit (see above)	
Anti-extrusion ring	14
Oil valve assembly	
consisting of:	
Valve assembly (items 9-13)	9
Anti-extrusion ring	14
Washer	15
O-ring	16
Spacer	17
Lock nut	18
Vent screw	19
Support ring	23

* available separately

¹⁾ When ordering please state smallest bladder connection port size.

Item 1 not available as a spare part.

Item 19 for NBR/Carbon steel:

seal ring (item 20) included

Item 25 must be ordered as an accessory (see Point 4).

3.3. REPAIR KITS

NBR, carbon steel

Nom. volume: 0.5 ... 200 litres

Standard gas valve

Nom. volume [l]	Part no.
0.5	02128169
1	02106261
2.5	02106200
4	02106204
5	02106208
6	02112100
10 ^{*)}	03117512
10	02106212
13	02106216
20	02106220
24	02106224
32	02106228
50	02106252
60	03117513
80	03117514
100	03117515
130	03117516
160	03117517
200	03117558

^{*)} slimline version for confined spaces
others on request

4. ACCESSORIES FOR BLADDER ACCUMULATORS

4.1. ADAPTERS (GAS SIDE)

To monitor the accumulator pre-charge pressure, HYDAC offers a selection of gas side adapters.

These must be ordered separately

4.1.1 Pressure gauge model:

Gas side connection on the bladder accumulator for permanent monitoring of the pre-charge pressure

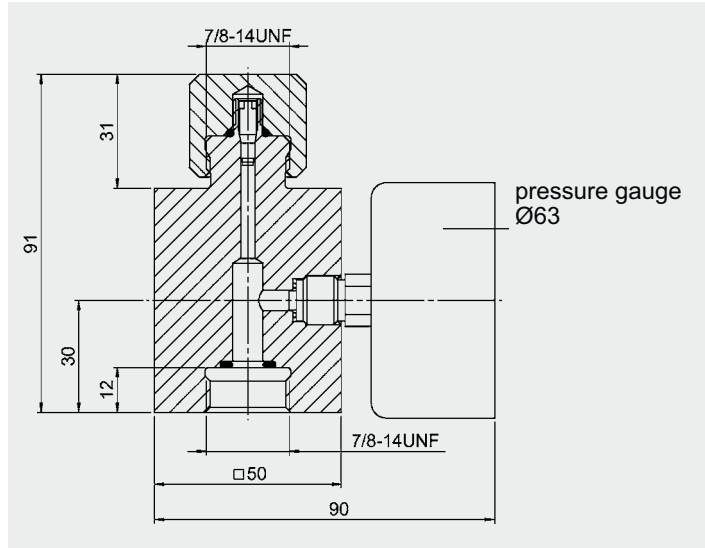

Gauge indication range	Gauge Part no.	Adapter body* Part no.	Adapter assembly Part no.
-	-	00239275	00366621
0 - 10 bar	00614420		02108416
0 - 60 bar	00606886		03093386
0 - 100 bar	00606887		02104778
0 - 160 bar	00606888		03032348
0 - 250 bar	00606889		02100217
0 - 400 bar	00606890		02102117

* p_{max} = 400 bar

4.1.2 Pressure gauge model with shut-off valve

Gas side connection on the bladder accumulator for permanent monitoring of the pre-charge pressure with shut-off option.

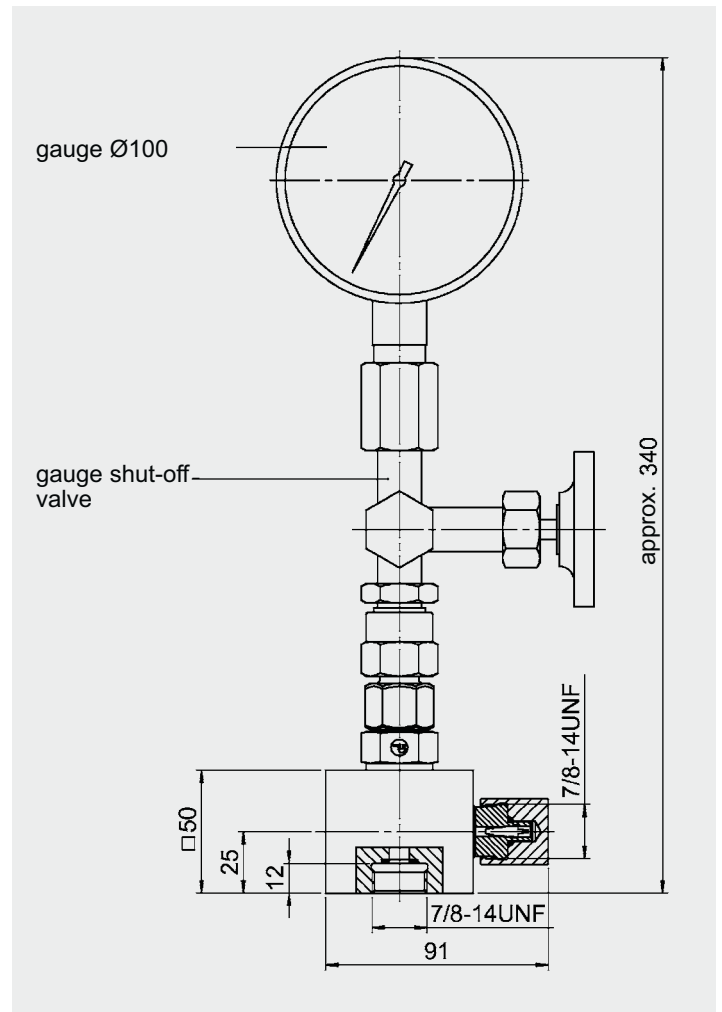

Gauge indication range	Gauge Part no.	Adapter body* Part no.	Adapter assembly Part no.
-	-	00363713	02103381
0 - 25 bar	00631380		02105216
0 - 60 bar	00606771		02110059
0 - 100 bar	00606772		03139314
0 - 160 bar	00606773		03202970
0 - 250 bar	00606774		03194154
0 - 400 bar	00606775		02103226

* p_{max} = 400 bar

4.1.3 Remote monitoring of the pre-charge pressure

To monitor the pre-charge pressure in hydraulic accumulators remotely, gas side adapters with pressure gauge and mounting holes are available.

In order to connect these adapters directly with the hydraulic accumulator using appropriate lines, accumulator adapters are also available for connection at the top (see diagram 1) or for side-connection (see diagram 2).

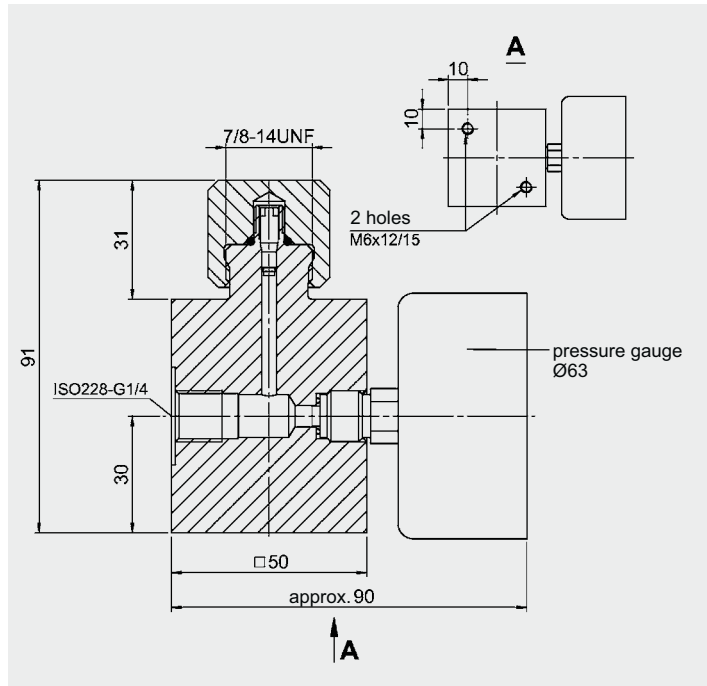

Gauge indication range	Gauge Part no.	Adapter body* Part no.	Adapter assembly Part no.
–	–	02116746	03037666
0 - 10 bar	00614420		03095818
0 - 60 bar	00606886		03095819
0 - 100 bar	00606887		03095820
0 - 160 bar	00606888		03095821
0 - 250 bar	00606889		03095822
0 - 400 bar	00606890		03095823

* p_{max} = 400 bar

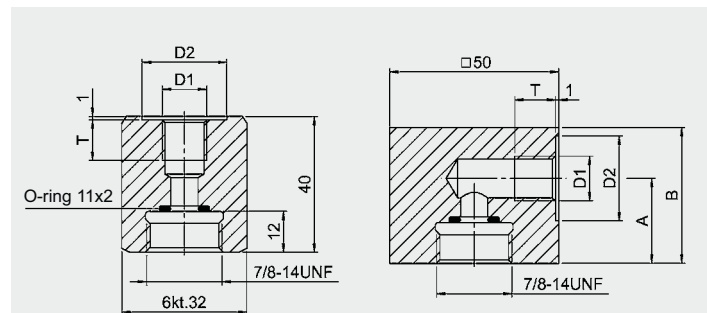

Diagram 1

Diagram 2

D1 Threaded connection	D2 [mm]	T	Adapter body* Part no.	Adapter assembly Part no.	Diag.
ISO228- G 1/4	25	14	00238709	02109481	1
			00241740	02102042	2
ISO228- G 3/8	28		00355021	02109483	1
			03280414	00366607	2
ISO228- G 1/2	34	16	02110594	02110636	1
			00237884	00366608	2

* p_{max} = 400 bar

4.2. ADAPTERS FOR STANDARD BLADDER ACCUMULATORS (FLUID SIDE)

to connect the bladder accumulator to pipe fittings. These are available separately.

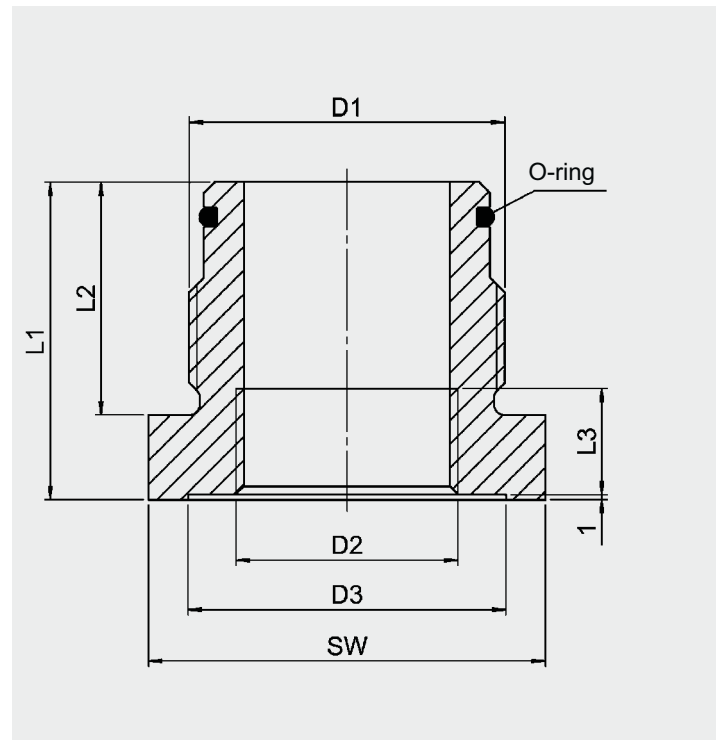

D1 Accum. conn.* (ISO228-BSP)	D2 [mm]	D3 [mm]	L1 [mm]	L2 [mm]	L3 [mm]	SW [mm]	O-ring [mm]	Part no. NBR/ Carbon steel
G 3/4	G 3/8	28	55	28	12	32	17x3	02104346
	G 1/2	28	60	28	14	36		02104348
G 1 1/4	G 3/8	28	50	37	12	46	30x3	02116345
	G 1/2	34	50	37	14	46		02105232
	G 3/4	44	50	37	16	46		02104384
G 2	G 1	50	67	37	18	65	48x3	02110124
	G 1/2	34	60	44	14	65		02104853
	G 3/4	44	60	44	16	65		02104849
	G 1 1/4	60	60	44	20	65		02107113
	G 1 1/2	68	80	44	22	70		02105905

* others on request

5. NOTE

The information in this brochure relates to the operating conditions and applications described. For applications and operating conditions not described, please contact the relevant technical department. Subject to technical modifications.

HYDAC Technology GmbH

Industriegebiet

D-66280 Sulzbach/Saar

Tel.: 0 68 97 / 509 - 01

Fax: 0 68 97 / 509 - 464

Internet: www.hydac.com

E-Mail: speichertechnik@hydac.com

