

HYDAC

INTERNATIONAL

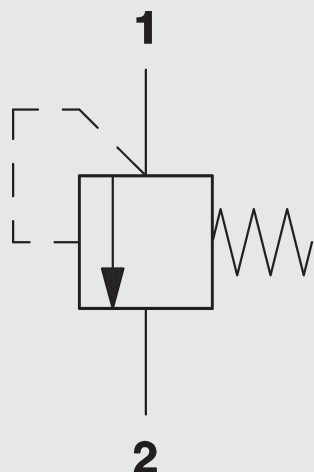

Pressure Relief Valve DB12-CE



up to 400 bar
up to 120 l/min

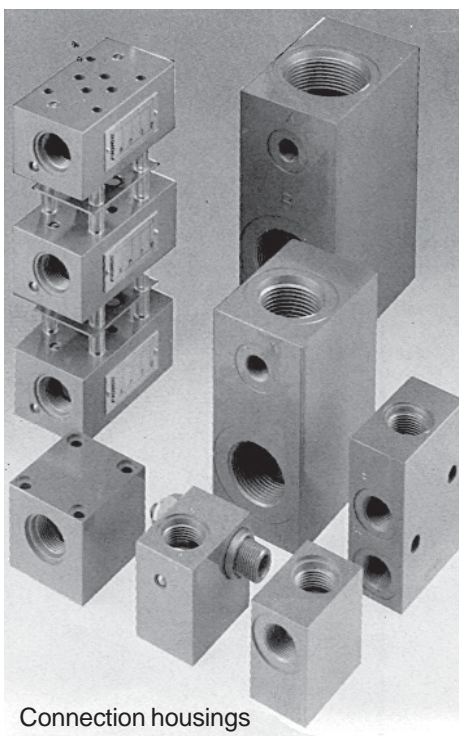

Connection housings

1. DESCRIPTION

1.1. GENERAL

According to DIN-ISO 1219, HYDAC pressure relief valves DB12-CE are valves for oil hydraulic systems to control pressure across the inlet by opening the outlet against a spring force. The valve is designed as a direct-operated pressure relief valve in seat valve construction. This provides very good opening/closing characteristics and enables user units to be sealed leakage-free.

Further advantages of these valves are as follows:

- cavity dimensions to ISO 7789
- low hysteresis and high stability ensure accurate pressure control
- optimum system adaptation owing to various pressure ranges
- limited setting range means that the spring cannot be blocked, thereby maintaining the pressure relief function
- the damping unit ensures that a stable operation is maintained over the whole capacity range and that the noise level is kept to a minimum
- small pressure increase at increased flow rate over the whole application range due to hydrodynamic lift support on the spring plate
- mechanical lift stop ensures operational safety even when pressure peaks cause an overload
- their compact design saves space when installing in connection housings, control blocks etc., especially in confined installation conditions.
- simple installation due to service-friendly cartridge valve technology

According to the Pressure Equipment Directive 97/23/EC, safety devices to prevent excess pressure (safety valves) form part of pressure vessel equipment.

Pressure relief valves DB12...CE comply with the Pressure Equipment Directive 97/23/EC.

The pressure relief valves are set, inspected and sealed by the factory-authorized inspector in accordance with the order specifications (pressure setting).

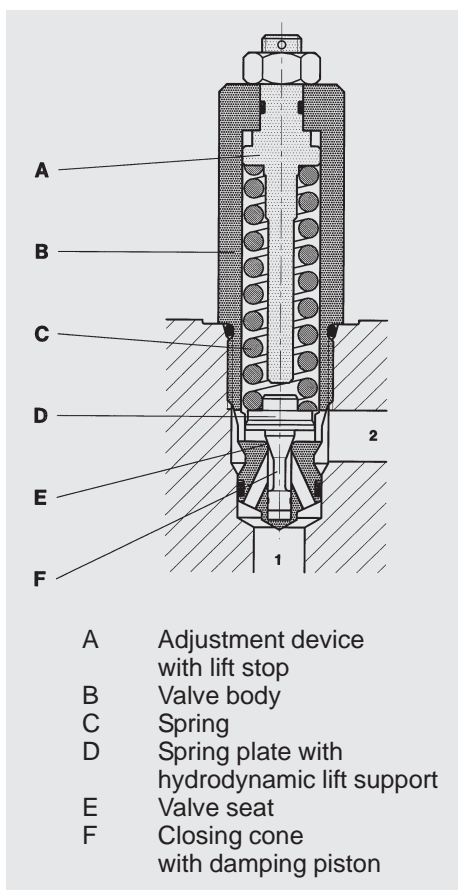

1.2. FUNCTION

The valve consists essentially of a valve body with built-in valve seat, a hardened and polished closing cone and the adjustment device for setting the initial spring tension. The spring applies this force to the closing cone and pushes it against the valve seat. On the opposite side of the closing cone, the system pressure acts via port 1 of the valve. If the hydraulic pressure force is below the pre-set spring tension, the valve is closed. If the hydraulic pressure force exceeds the pre-set spring tension, the closing cone is lifted off the valve seat and the operating fluid flows from pressure port 1 to tank port 2. This limits the pressure across port 1. To ensure that stable operation is maintained, the closing cone is rigidly connected to the damping piston which has to displace oil via an aperture with each movement of the closing cone. Each time, this produces an opposing damping force to the direction of movement.

1.3. APPLICATION

HYDAC pressure relief valves DB12-CE are used as safety valves to limit pressure to the maximum permissible, according to Pressure Equipment Directive (PED) 97/23/EC.

1.4. NOTES



Warning

- For correct operation, the application range and the ambient parameters must not be exceeded.
- Lead seal must not be broken.
- Pressure setting must not be altered.
- Plastic cap must not be damaged.
- Type code must remain visible and legible so that clear identification is possible.
- The type of valve must be clearly identifiable from the type code, see 2.1.2.



Danger

- If the connections are incorrect, the safety function of the valve is disabled, see 2.1.1 and 3.
- When fitting the valves into control blocks and housings, the given torque values must be observed, see 3.
- Tank pressure (port 2) must be $p_{2 \max} = 0$ bar.
- Dismantling the valve is not permitted.
- Only appropriate tools must be used to fit the valve.
- After a breakdown in the system (e.g. fire) the DB12 valve must be replaced for safety reasons.

2. TECHNICAL SPECIFICATIONS

2.1. GENERAL

2.1.1 Designation and symbol Pressure relief valve

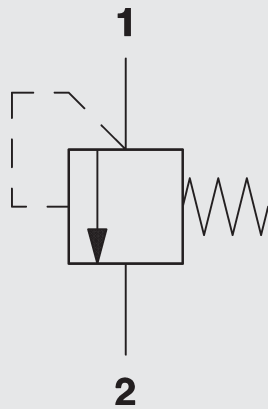

2.1.2 Model code (also order example)

DB12120A-010 - CE0034.ENISO4126.6L. Q.p

Pressure relief valve

Component approval mark

Q_{max}

Max. permissible flow rate of pump
(see table for use with model code in l/min)

p

pressure setting in bar

Standard models:

Stock no. (= order no.)	Model code
3108627	DB12120A-010-CE0034.ENISO4126.6L.110.210
3108635	DB12120A-010-CE0034.ENISO4126.6L.110.330

Please quote stock number when ordering.

Non-standard models are custom-built (minimum order quantity 50 pieces).
Delivery for non-standard models is longer and the price is higher.

Table for use with model code (see also 2.2.7 Application range):

p (bar)	Q _{max} (l/min)
30	65
35	65
40	72
50	80
60 - 80	80
95	90
100 - 105	95
110 - 150	110
160 - 250	110
260 - 350	110
360 - 400	110

2.1.3 Type of construction

Cone-seat valve, direct-operated

2.1.4 Type of mounting

Cartridge valve

2.1.5 Mounting position

Optional

2.1.6 Weight

0.42 kg

2.1.7 Direction of flow

From 1 to 2, pressure relief function

From 2 to 1, shut-off leakage-free

2.1.8 Ambient temperature range

min. -20 °C

max. +80 °C

2.1.9 Materials

Valve body: high tensile steel

Closing element: hardened and polished steel, wear-resistant

Seals: FPM and Teflon

2.2. HYDRAULIC DETAILS

2.2.1 Nominal pressure

inlet (port 1): up to 400 bar
 outlet (port 2): DB12-CE: up to 0 bar

2.2.2 Operating pressure ranges

up to 150 bar
 up to 250 bar
 up to 350 bar
 up to 400 bar
 for lowest setting pressures, see 2.2.8 Pressure, dependent on flow rate

2.2.3 Pressure fluid

Mineral oil to DIN 51524, part 1 and 2

2.2.4 Operating fluid temperature range

min. -20 °C
 max. +80 °C

2.2.5 Viscosity range

min. 10 mm²/s
 max. 380 mm²/s

2.2.6 Filtration

Max. permissible contamination level of the operating fluid to ISO 4406 class 21/19/16 (NAS 1638 class 10). We therefore recommend a filter with a minimum retention rate of $\beta_{20} = 100$.

The fitting of filters and regular replacement of elements ensures correct functioning, reduces wear & tear and increases the service life.

2.2.7 Application range

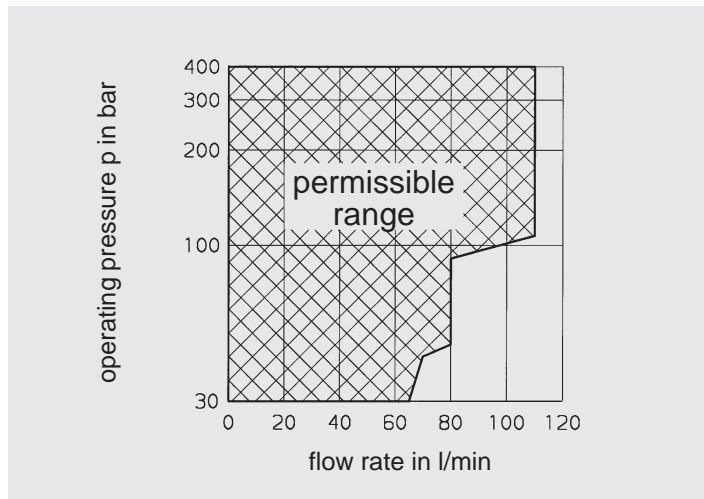

2.2.8 Pressure, dependent on flow rate

measured at $v = 28 \text{ mm}^2/\text{s}$ and $t_{\text{oil}} = 50 \text{ °C}$

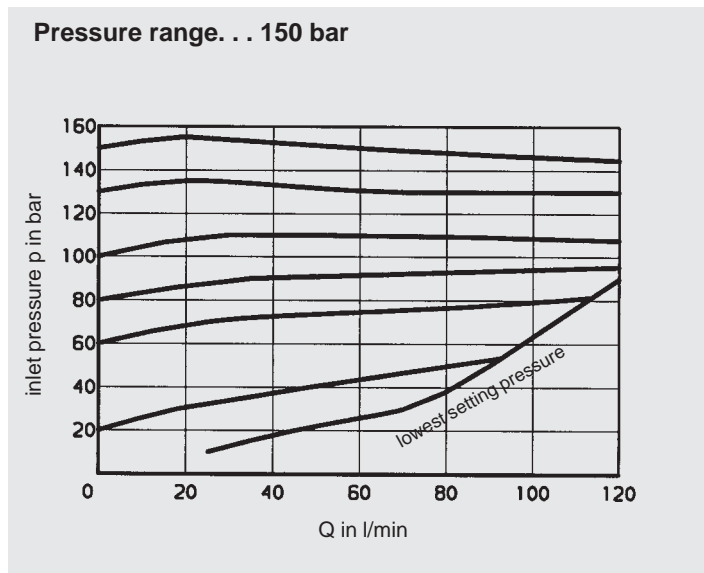

Pressure range . . . 250 bar

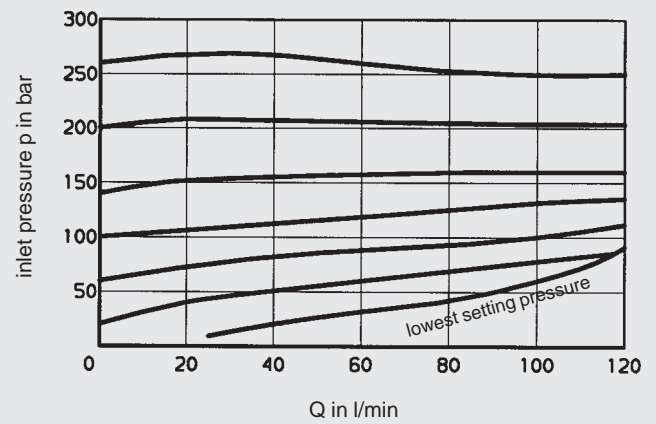

Pressure range . . . 350 bar

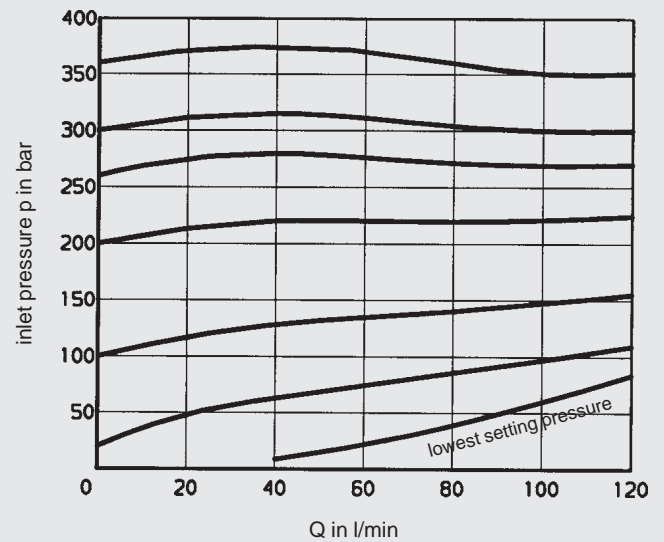

Pressure range . . . 420 bar

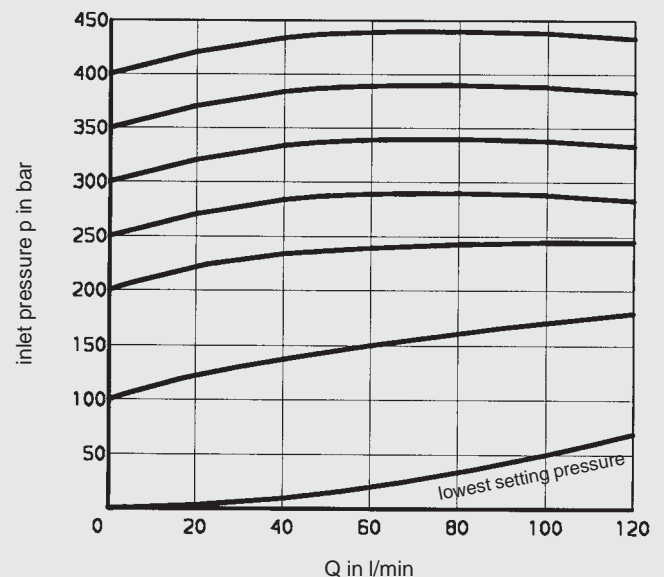

3. DIMENSIONS DB12

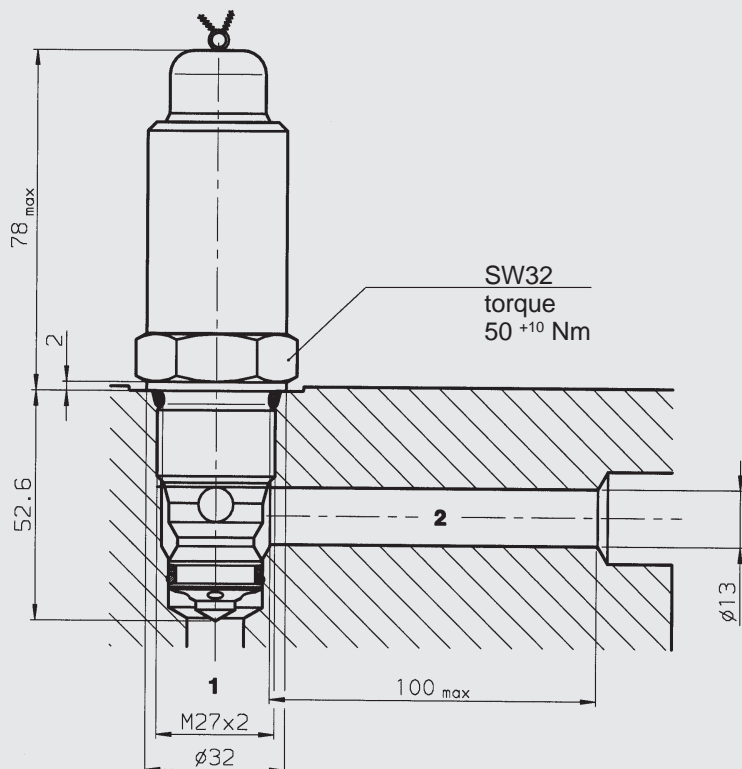

4. NOTE

The information in this brochure relates to the operating conditions and applications described.

For applications or operating conditions not described, please contact the relevant technical department.

Subject to technical modifications.

CAVITY DIMENSIONS 12120A (TO ISO 7789)

Geometry

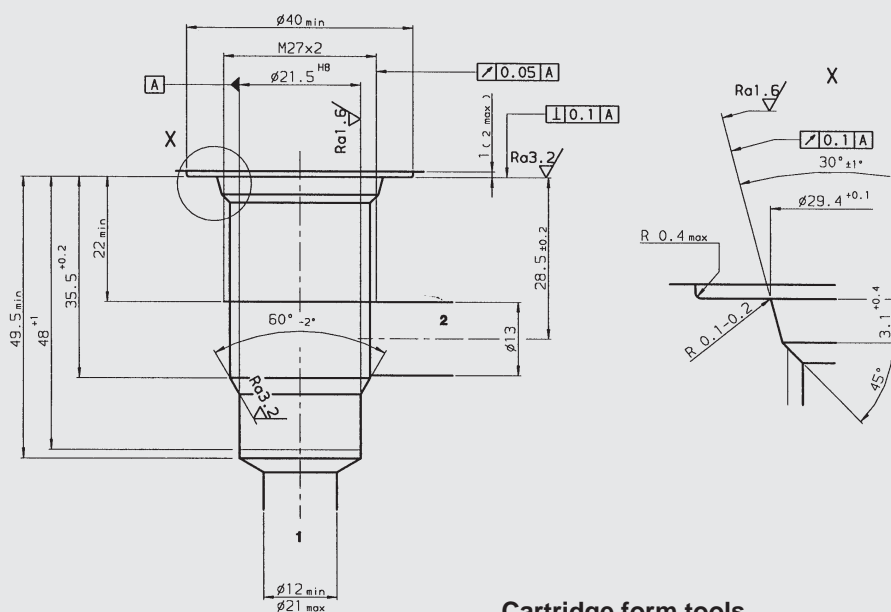

Cartridge form tools

Tool	Stock no.
Countersink	175 002 / 162 128
Reamer	174 874
Tap	1002625
Plug gauge	in preparation