

Ball Valves for Manifold Block Mounting KHP

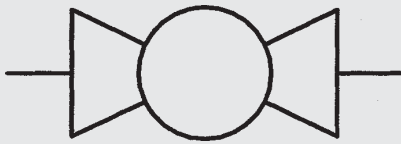

up to 500 bar
up to DN 50

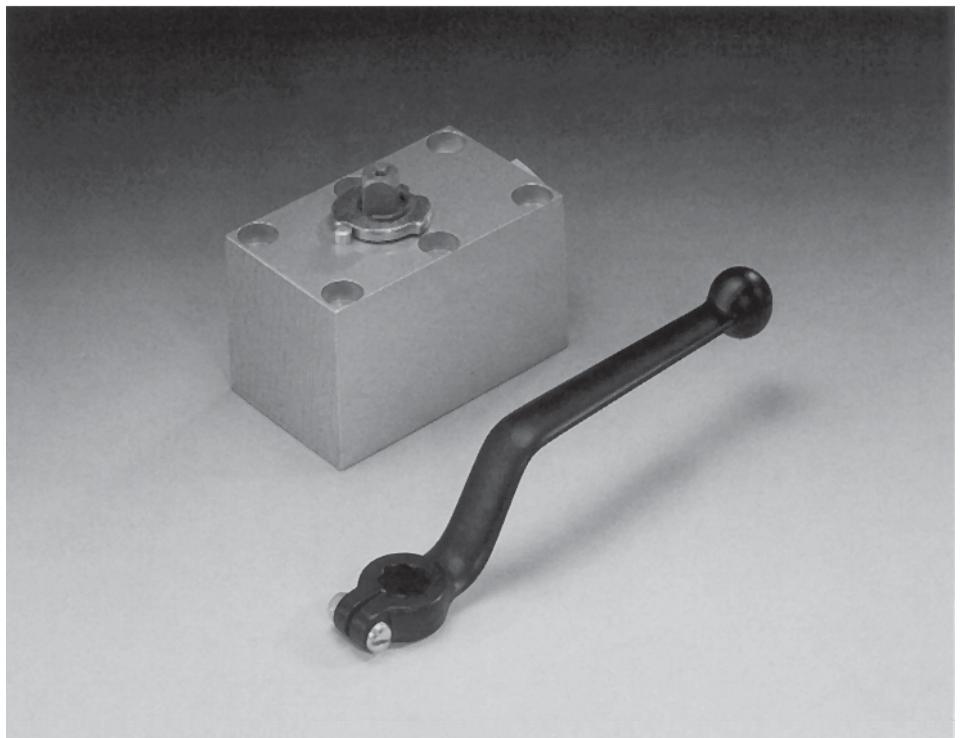
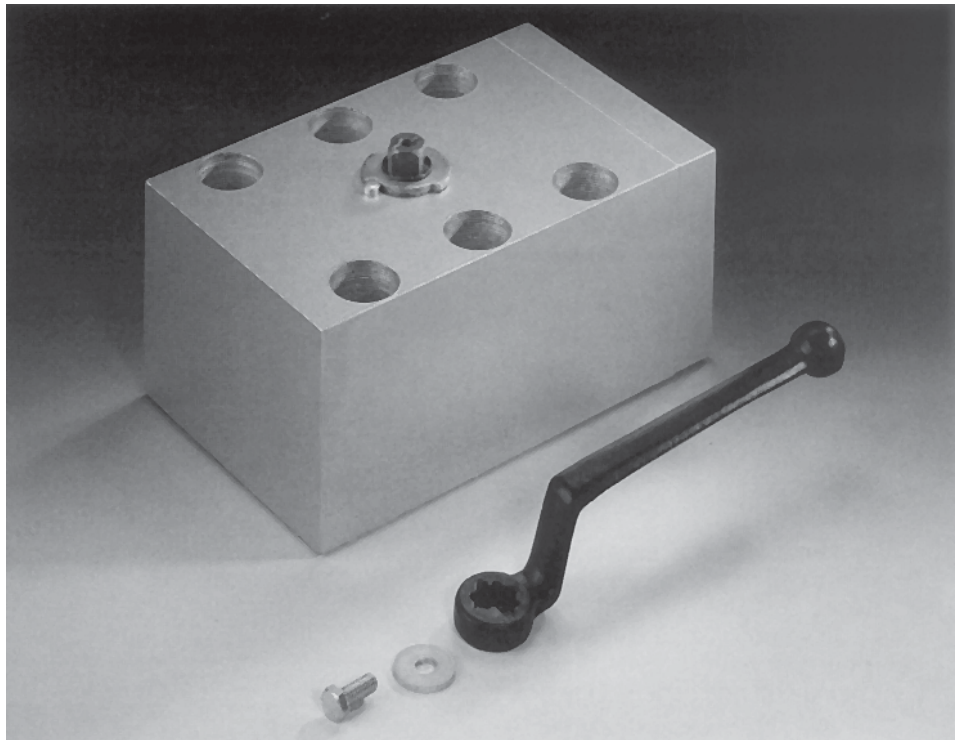

1. DESCRIPTION

1.1. GENERAL

According to DIN-ISO 1219, FLUTEC 2/2 directional ball valves for manifold block mounting are units which serve to shut off the flow of an operating medium in both directions.

These ball valves have the following advantages:

- Visual indication of the switching position by means of a slot on the control spindle
- Switching limited by means of stop pin and stop disc
- No glands, therefore no manual re-adjustment of seals required
- Sealing principle with floating ball, sealing on outlet side
- Full flow passage for unrestricted flow of medium
- Easy operation
- Surface phosphate-plated

FLUTEC manifold mounted ball valves are available in stainless steel.

FLUTEC handle, for full details see brochure no. E 5.515../..

On request we can supply other models to cover nearly all applications, eg for aggressive or gaseous media as well as quality test certificates to DIN 55350, Part 18.

1.2. FUNCTION

Turning the control spindle moves the ball from the open to the closed position. The system pressure pushes the ball against the sealing cup and shuts off the flow leakage-free.

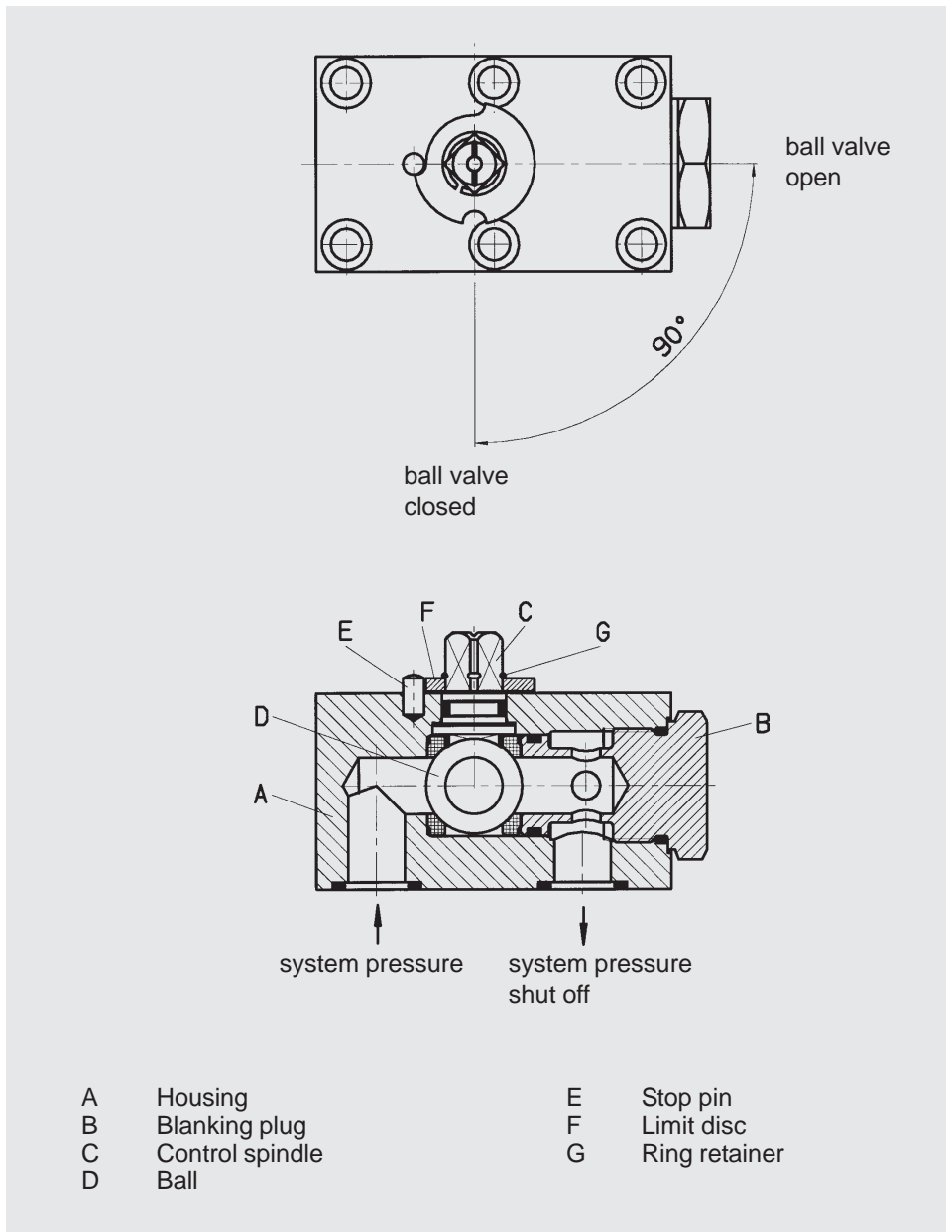

1.3. APPLICATION

FLUTEC 2/2 directional ball valves for manifold block mounting are used to shut off flow in hydraulic circuits.

Areas of application are for example:

- Machine tools
- System engineering
- Off-shore sector
- Valve and/or control block combinations

1.4. NOTES

Ball valves are not designed to be used as flow control valves; therefore they should always be either fully open or fully closed in order to avoid damaging the sealing cups.

To ensure correct functioning, pressure and temperature specifications must be observed.

O-rings for the connection side are supplied with the ball valve.

The handles are supplied loose with the ball valves.

2. TECHNICAL SPECIFICATIONS

2.1. GENERAL

2.1.1 Designation and symbol Manifold mounted ball valve KHP

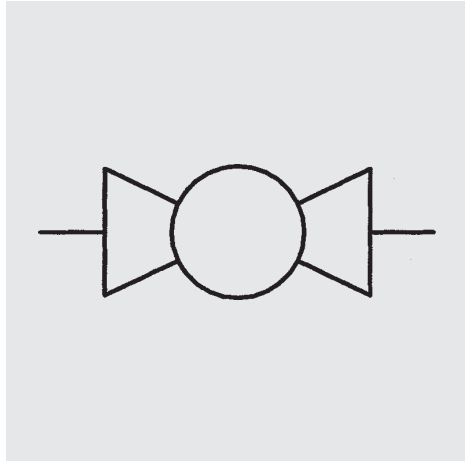

2.1.2 Model code (also order example)

KHP - 10 - 1214 - 04 X

Designation _____
KHP = Manifold mounted ball valve

Nominal width _____

Materials

	Material code
Housing, blanking plug and control spindle (steel)	1 _____
Ball (brass) DN 10-25 1 = (steel) DN 06, 32-50	2 _____
Sealing cups (POM)	1 _____
Control spindle and connection seal Viton (FKM) 2 = Perbunan (NBR)	4 _____

Type

14 = zinc die-cast bolt-on handle, cranked (ZK), fitted DN 06
04 = zinc die-cast bolt-on handle, cranked (ZK) DN 10
02 = aluminium clamped handle, cranked (AK) DN 16 - 25
06 = steel bolt-on handle, cranked (SK) DN 32 - 50
09 = without handle (DN 10 - 50)

Series

(determined by manufacturer)

Please quote stock no. when ordering (see table 2.1.3)
Delivery for non-standard models is longer and the prices are higher.

2.1.3 Standard models

Type / nominal width	Nominal width DN	Nominal pressure PN [bar]	Order no. = stock no.	Weight [kg]
KHP- 06 - 1114 - 14X	06	500	554 028	0.60
KHP- 10 - 1214 - 04X	10	315	702 126	1.20
KHP- 16 - 1214 - 02X	16	315	702 129	2.10
KHP- 20 - 1214 - 02X	20	315	702 132	3.70
KHP- 25 - 1214 - 02X	25	315	702 135	5.60
KHP- 32 - 1114 - 06X	32	315	702 657	10.90
KHP- 40 - 1114 - 06X	40	315	703 845	17.40
KHP- 50 - 1114 - 06X	50	315	703 846	24.50

2.1.4 **Type of construction**
Shut off device is a ball.

2.1.5 **Type of connection**
Manifold block connection for mounting onto valve or control blocks.

For interface, see page 7.

2.1.6 **Mounting position**
Optional

2.1.7 **Weight**
(see table 2.1.3)

2.1.8 **Flow direction**
Optional

2.1.9 **Ambient temperature**
- 10° C to + 80° C

2.1.10 **Materials**
Housing, blanking plug and control spindle in steel, surface: phosphate plated
Ball for nominal widths 10 - 25 in brass, hard-chromed
Ball for nominal widths 06, 32 - 50 in steel, hard-chromed
Ball seal in high quality synthetic material (POM)

Soft seals in Viton (FKM) or Perbunan (NBR)

Cranked handle
SW 06 and SW 09 in zinc die-casting, zinc-plated DN 06 - 10
SW 12 - 14 in aluminium, red anodised DN 16 - 25 and SW 17 in steel, zinc-plated DN 32 - 50

2.2. HYDRAULIC DETAILS

2.2.1 **Nominal pressure**
PN 315 bar to PN 500 bar (see table 2.1.3)

2.2.2 **Operating fluids**
Mineral oil to DIN 51524, Part 1 and 2 (other media on request)

2.2.3 **Temperature of operating fluid**
- 10° C to + 80° C

3. DIMENSIONS

3.1. HANDLE

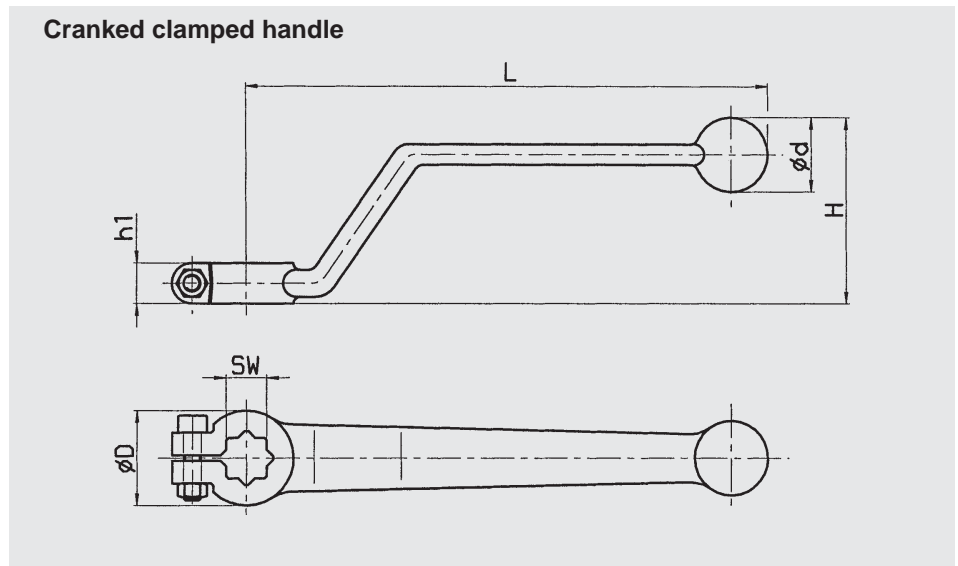

L	H	ØD	Ød	h1	SW	Ball valve nominal width	Type	Order no. = stock no.
185	47	28	22	12	12	16	02 (AK)	270381
203	54	32	24	12	14	20 - 25	02 (AK)	270382

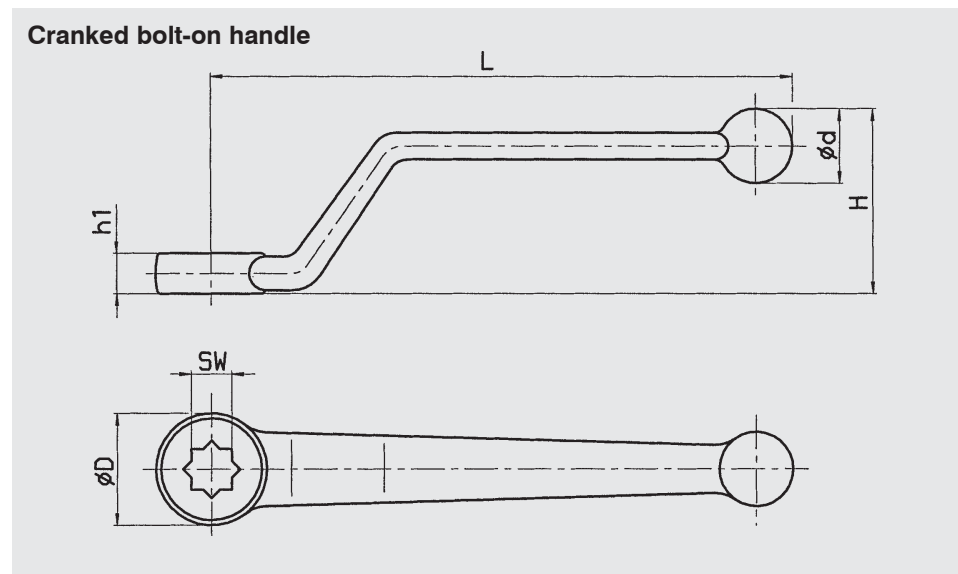

L	H	ØD	Ød	h1	SW	Ball valve nominal width	Type	Order no. = stock no.	Fixing bolt stock no.
60	23	20	10	8.5	06	06	14 (ZK)	389707	637051
108	36	22	15	9.5	09	10	04 (ZK)	556352	637052
210	80	34	20	14	17	32 - 50	06 (SK)	273662	638600

3.1.1 Notes on assembly

The clamped handle is pushed onto the square end of the ball valve spindle and clamped to the square by means of a bolt through the side of the handle.

Clamped handle

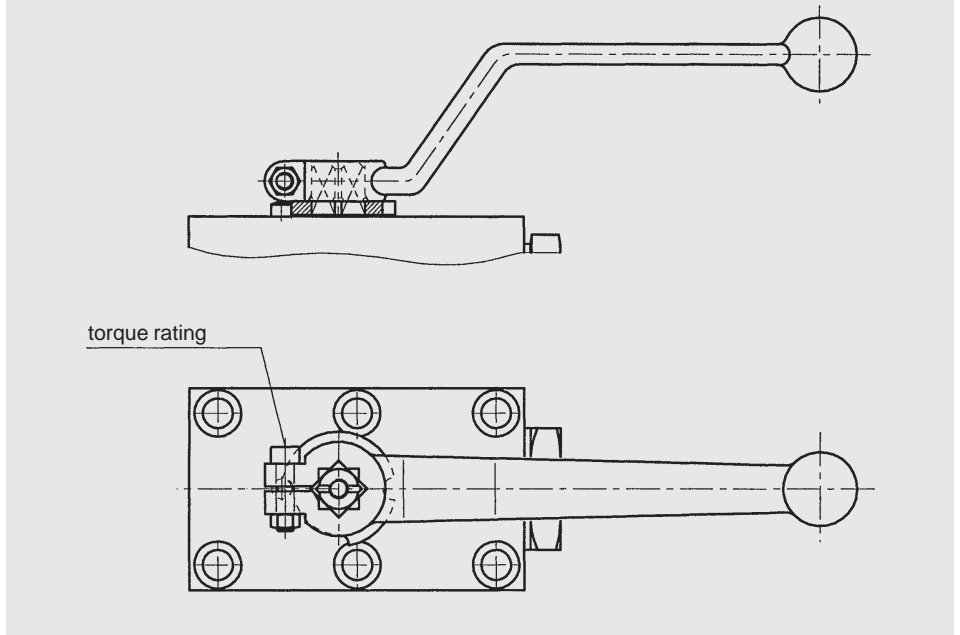

	SW 12	SW 14
Bolt	M 5 x 20	M 6 x 30
Torque rating	3 Nm	5 Nm

The bolt-on handle is screwed onto the ball valve control spindle from above using a fixing bolt.

Bolt-on handle

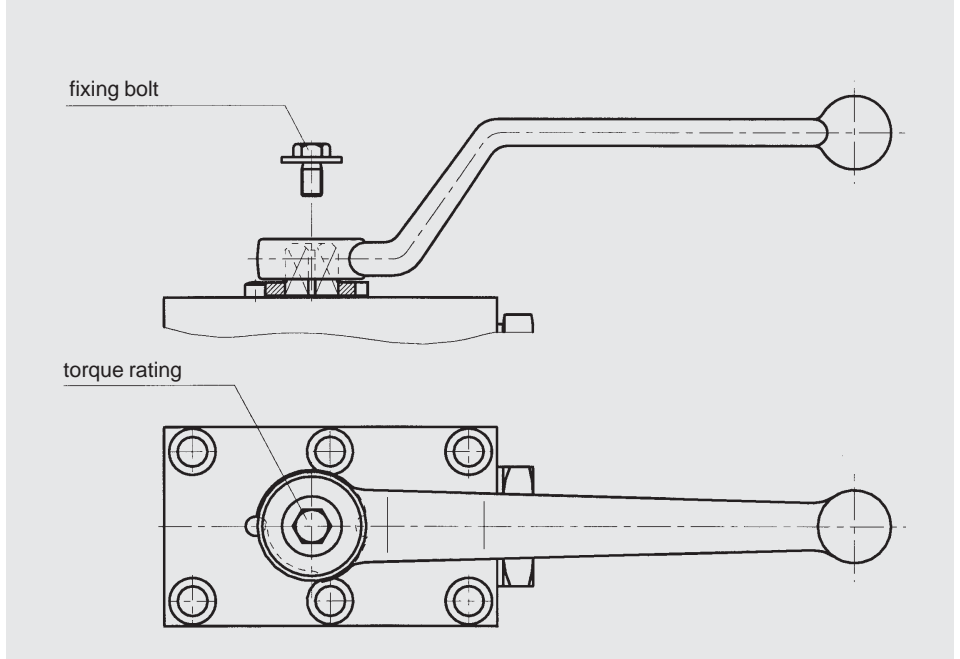

	SW 06	SW 09	SW 17
Fixing bolt	M 3x8	M 5x12	M 8x16
Torque rating	0.6 Nm	3 Nm	5 Nm

Both types of handle can be displaced by 45° (exception: SW 06).

3.2. BALL VALVES FOR MANIFOLD BLOCK MOUNTING

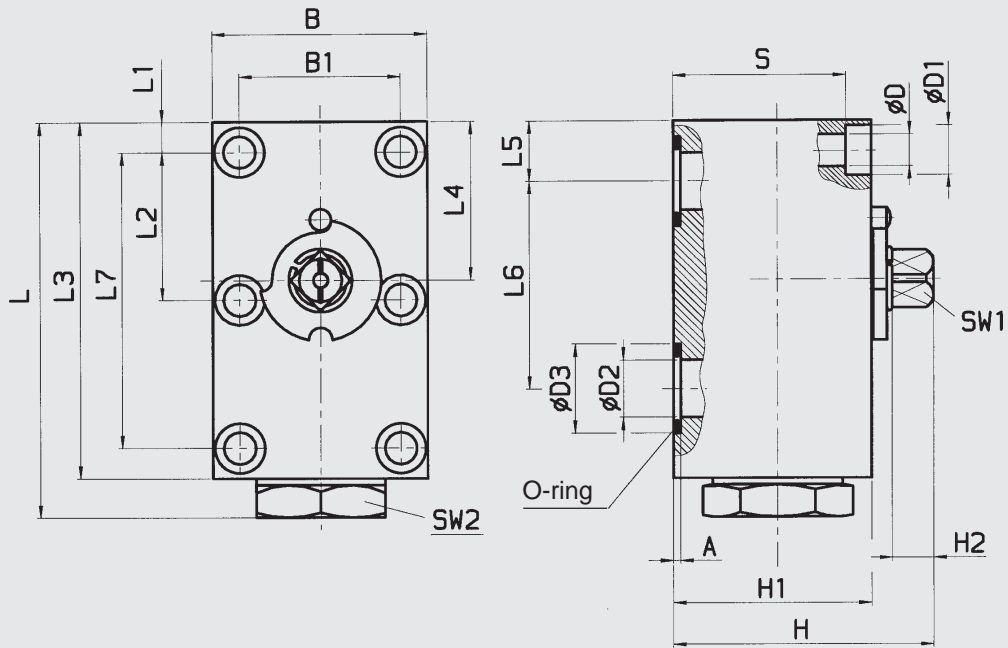

Type / nominal width	DN	LW	L	L1	L2	L3	L4	L5	L6	L7	B	B1
KHP-06	06	6.0	64.0	8.5	17.5	59.0	25.0	8.5	35.0	35.0	40	27
KHP-10	10	9.5	80.0	7.5	27.5	70.0	29.0	10.0	44.0	55.0	55	40
KHP-16	16	16.0	110.0	8.5	41.5	100.0	44.5	17.0	58.0	83.0	60	45
KHP-20	20	20.0	127.0	10.0	48.5	117.0	51.0	20.0	69.0	97.0	70	51
KHP-25	25	23.5	145.0	10.0	57.5	135.0	62.0	24.0	81.0	115.0	80	60
KHP-32	32	30.0	176.0	12.0	68.0	165.0	75.0	29.0	96.0	136.0	100	78
KHP-40	40	38.0	205.0	28.5	56.0	180.0	85.0	28.5	112.0	112.0	130	95
KHP-50	50	48.0	245.0	38.0	68.0	220.0	106.0	38.0	136.0	136.0	149	112

Type / nominal width	SW 1	SW 2	H	H1	H2	D	D1	D2	D3	A	S	O-ring
KHP-06	6	22	37.5	30.0	7.0	6.6	11.0	6.0	11.7	1.6	23.0	8x2
KHP-10	9	30	58.0	45.0	8.5	9.0	14.0	9.5	15.0	2.0	36.0	10x2.6
KHP-16	12	36	72.5	55.0	11.0	9.0	14.0	16.0	25.0	2.0	46.0	20.29x2.62
KHP-20	14	41	88.5	70.0	11.0	10.5	16.5	20.0	30.0	2.9	59.5	23.39x3.53
KHP-25	14	50	97.5	80.0	11.0	10.5	17.0	23.5	35.0	2.9	69.0	28.17x3.53
KHP-32	17	65	118.5	100.0	12.0	13.0	19.0	32.0	39.4	2.9	84.0	32.92x3.53
KHP-40	17	-	118.5	100.0	12.0	17.5	26.0	38.0	48.4	2.9	82.5	42x3.5
KHP-50	17	-	129.0	110.0	12.0	22.0	33.0	48.0	55.4	2.9	88.5	49x3.5

Type / nominal width	Int. hex. screw DIN 912	Torque rating MA [Nm] (standard values for friction coefficient μ 0.14)
KHP-06	M 6 - 10.9	13
KHP-10	M 8 - 10.9	30
KHP-16	M 8 - 12.9	35
KHP-20	M 10 - 12.9	60
KHP-25	M 10 - 12.9	60
KHP-32	M 12 - 12.9	110
KHP-40	M 16 - 12.9	300
KHP-50	M 20 - 12.9	600

3.3. INTERFACE FOR MANIFOLD BLOCK MOUNTED BALL VALVE

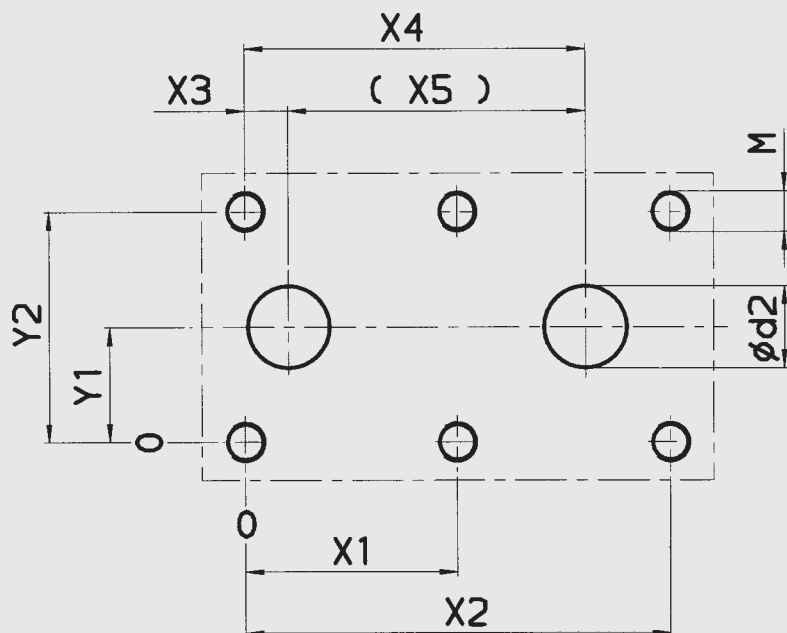

required surface finish
on interface area

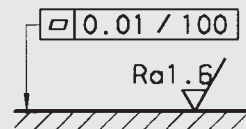

dimensional tolerances
ISO 2768 m

Type / nominal width	Y1	Y2	X1	X2	X3	X4	X5	d2	M
KHP-06	13.5	27.0	17.5	35.0	0.0	35.0	35.0	6.0	M 6
KHP-10	20.0	40.0	27.5	55.0	2.5	46.5	44.0	9.5	M 8
KHP-16	22.5	45.0	41.5	83.0	8.5	66.5	58.0	16.0	M 8
KHP-20	25.5	51.0	48.5	97.0	10.0	79.0	69.0	20.0	M 10
KHP-25	30.0	60.0	57.5	115.0	14.0	95.0	81.0	23.5	M 10
KHP-32	39.0	78.0	68.0	136.0	17.0	113.0	96.0	32.0	M 12
KHP-40	47.5	95.0	56.0	112.0	0.0	112.0	112.0	38.0	M 16
KHP-50	56.0	112.0	68.0	136.0	0.0	136.0	136.0	47.0	M 20

4. SPARE PARTS

Seal kit	Order no. = stock no.
DN 06	554 029
DN 10	702 113
DN 16	703 115
DN 20	703 099
DN 25	703 116
DN 32	700 977
DN 40	552 968
DN 50	554 241

5. NOTE

The information in this brochure relates to the operating conditions and applications described.

For applications or operating conditions not described, please contact the relevant technical department.

Subject to technical modifications.