



3- and 4-Way Manifold Mounted Ball Valves KH3P / KH4P

Model code

(also order example)

KH3P 16 L 1114 02 X

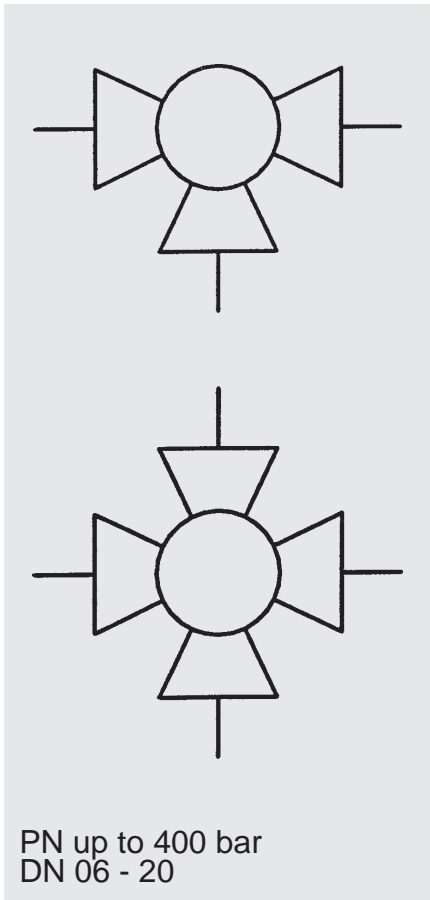

PN up to 400 bar
DN 06 - 20

Designation

KH3P = 3-way manifold mounted ball valve
KH4P = 4-way manifold mounted ball valve

Nominal bore

Ball bore

L, T, X
(according to table on page 2)

Material codes

1	1	1	4
Steel	Steel	Synthetic material (POM)	Viton (FKM)
Housing	Blanking plug	Ball spindle	Ball seal
Blanking plug	Locking screw	Soft seal	
3	3	1	4
Stainless steel (AISI316Ti)	Stainless steel (AISI316Ti)	Synthetic material (POM)	Viton (FKM)
Housing	Blanking plug	Ball spindle	Ball seal
Blanking plug	Locking screw	Soft seal	

(other material combinations available on request)

Handle

09 = without handle
02 = aluminium handle, cranked (supplied loose)

Series

(determined by manufacturer)

Special models

SO ... = special model according to customer specification
180° = switching movement 180°

(Please see examples on the next page)

Standard models

	Ball bore	Switching movement	Function diagram	SO ... model	
KH3P	L	0° - 90°			-
	T	0° - 45°			45°
	T	0° - 90°			-
	T	0° - 90° - 180°			180°
	L	0° - 45° - 90°			SO 378
	T	0° - 45° - 90°			SO 379
KH4P	T	0° - 90°			-
	X	0° - 45°			45°
	X	0° - 90°			-
	L	0° - 90° - 180°			180°
	T	0° - 90° - 180°			180°
	X	0° - 45° - 90°			SO 385
	T	0° - 45° - 90°			SO 389

* - detent position at 45°

--- undefined switching position

Other models or special ball bores on request

3- and 4-way manifold mounted ball valve with cranked aluminium handle

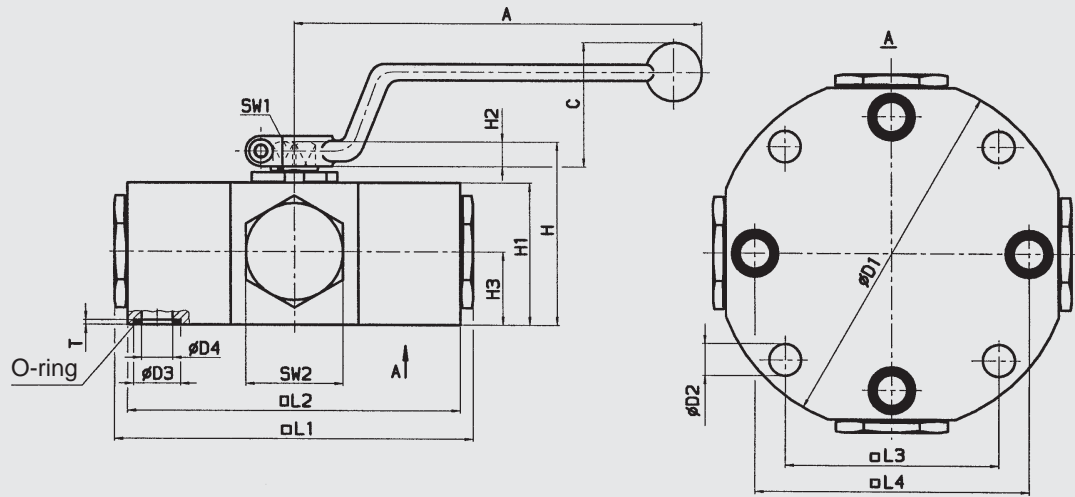

DN	LW	L	X	L1	L2	L3	L4	H	H1	H2	H3	D1	D2	D3	D4	SW 1	SW 2	T
	T-	-																
06	5	5	4.5	103	90	70	68.6	57	40	11	22	--	6.5	11.7	6	12	27	1.9
10	9	9	6	113	100	80	81	67.5	50	11.5	27	--	9	14.7	8	14	30	1.9
16	12	12	10	152.5	140	90	115.4	77.5	60	11.5	31.5	150	13.5	19.7	13	14	41	2
20	18	18	14	184	170	100	137	92	73	11.5	36	180	13.5	28.8	18	17	46	2

DN	A	C	O-ring	Weight [kg]	Pressure range PN [bar]
06	163	52	7.3 x 2.4	2.5	400
10	183	54	10.3 x 2.4	3.7	315
16	183	54	15 x 2.5	7.5	315
20	227	55	24 x 2.5	13.1	250

Interface for 3- and 4-way manifold mounted ball valve

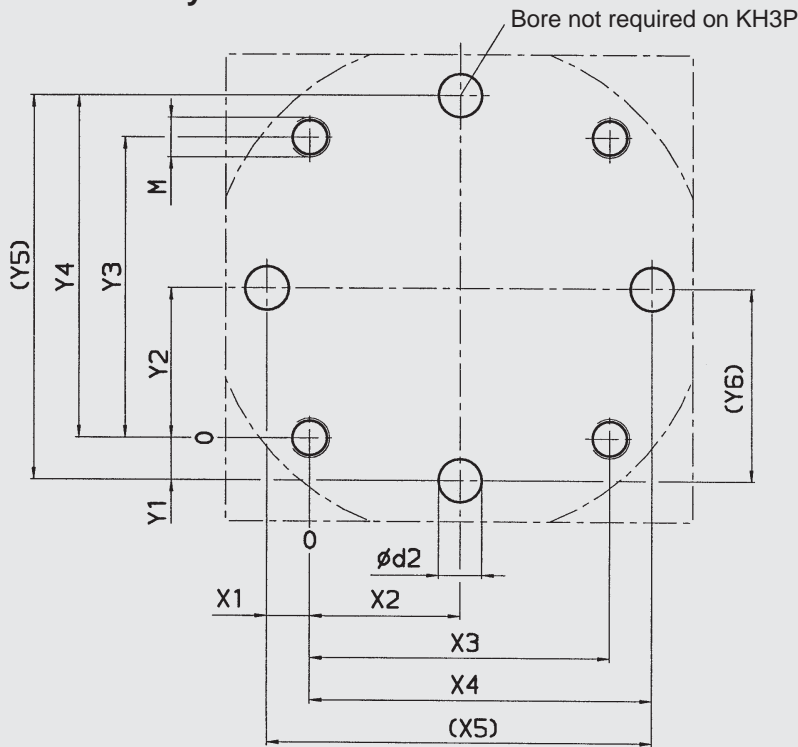

Required surface finish on interface area

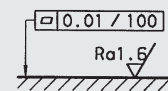

Dimensional tolerances ISO 2768 m

DN	Y1	Y2	Y3	Y4	Y5	Y6	X1	X2	X3	X4	X5	d2	M	Int. hex. screw ISO 4762 (Tensile strength)	Torque rating MA [Nm] *
06	0.7	35	70	69.3	68.6	34.3	0.7	35	70	69.3	68.6	6	M 6	M 6 - 12.9	10
10	-0.5	40	80	80.3	81.0	40.5	-0.5	40	80	80.5	81.0	8	M 8	M 8 - 12.9	20
16	-12.7	45	90	102.7	115.4	57.7	-12.7	45	90	102.7	115.4	13	M 12	M 12 - 12.9	65
20	-18.5	50	100	118.5	137.0	68.5	-18.5	50	100	118.5	137.0	18	M 12	M 12 - 12.9	70

* Standard values for friction coefficient μ 0.14

Technical specifications

Mounting position:	optional
Ambient temperature:	-10 °C to +80 °C
Nominal pressure:	up to PN 400 bar (see pressure range)
Operating fluids:	mineral oil to DIN 51524 Part 1 and Part 2 (other media on request)
Temperature of operating fluid:	-10 °C to +80 °C
Spare parts:	Seal kits available on request
Accessories:	All ball valves can be supplied with the following options: actuator limit controls lock

Note

The information in this brochure relates to the operating conditions and applications described. For applications or operating conditions not described, please contact the relevant technical department.

Subject to technical modifications.