

HYDAC

INTERNATIONAL

**Flange Type
Ball Valve
DN 65 - 300
KHMFF**

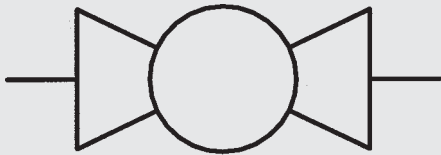

up to 40 bar
up to DN 300

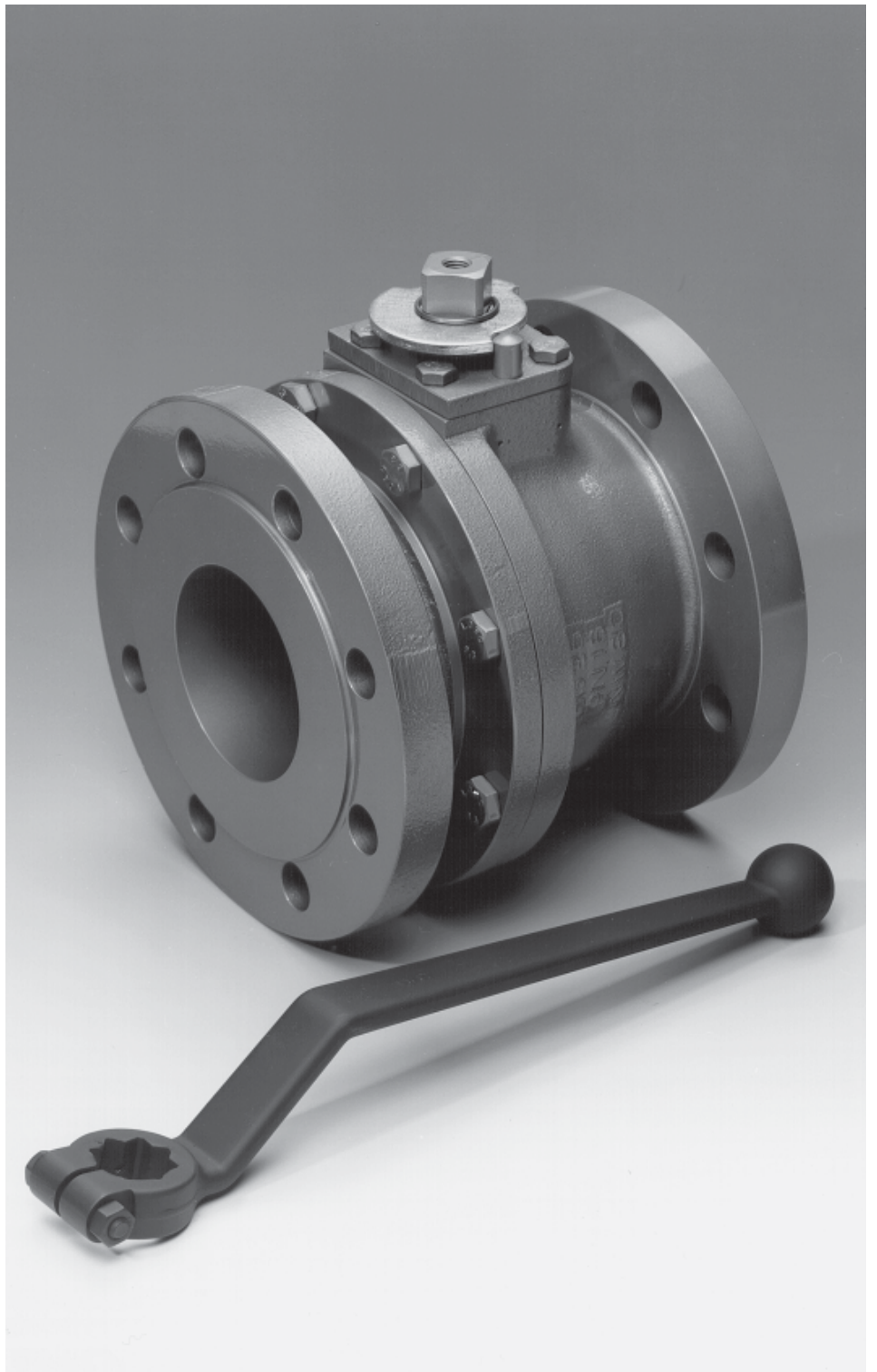

1. DESCRIPTION

1.1. GENERAL

According to DIN-ISO 1219, 2/2 flange type ball valves are units which serve to shut off the flow of an operating medium in both directions.

These ball valves have the following advantages:

- Visual indication of the switching position by means of a slot on the control spindle
- Visual indication of the switching position by means of the handle (KHMFF reduced version)
- Switching limited by means of stop pin and stop disc
- No glands, therefore no manual re-adjustment of seals required
- Full flow passage for unrestricted flow of medium (except for reduced nominal bores KHMFF)
- Sealing principle with floating ball, sealing on both sides
- Fixed flange connection
- Easy operation
- Surface phosphate-plated: DN 65 - 100
- Surface painted: reduced nominal bores and DN 125 - 300

Flange type ball valves DN 16 - 50, please see brochure no. E 5.502../...

FLUTEC flange type ball valves are available in stainless steel.

On request we can supply test certificates for material tests to EN 10204 and quality test certificates to DIN 55350, Part 18.

On request we can supply other models to cover nearly all applications.

Ball valve open

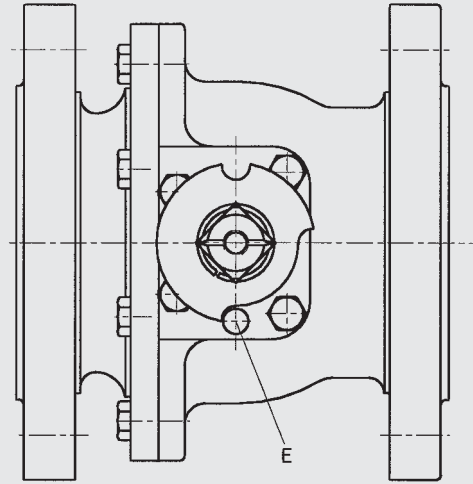

Ball valve closed

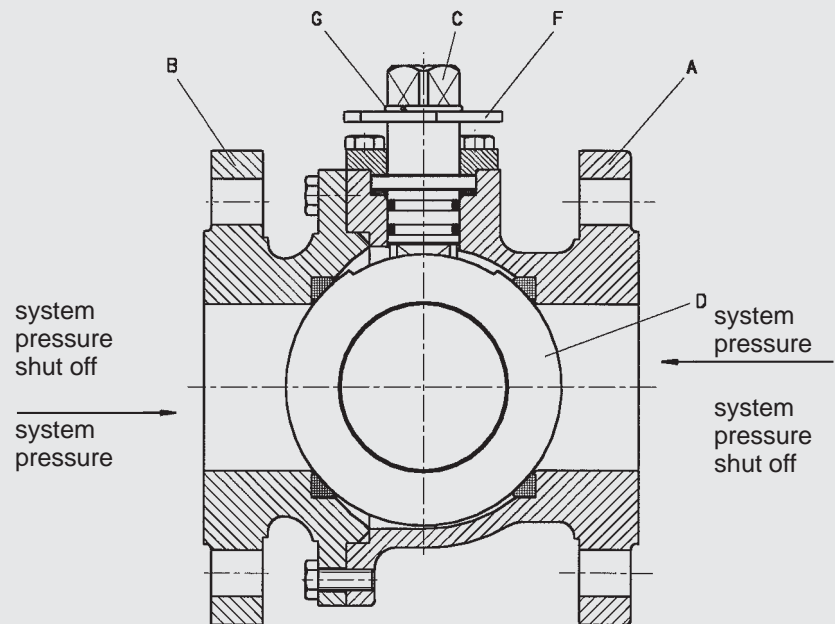

A Housing
B Flange
C Control spindle

D Ball
E Stop pin
F Limit disc
G Ring retainer

1.2. FUNCTION

Turning the control spindle moves the ball from the open to the closed switching position. The system pressure pushes the ball against the non-pressurised side of the sealing cup and shuts off the flow leakage-free.

1.3. APPLICATION

2/2 flange type ball valves are used to shut off flow in hydraulic circuits.

Areas of application are for example:

- Pipeline construction
- Off-shore sector
- Energy supply
- Steel works
- Power stations

1.4. NOTES

Ball valves are not designed to be used as flow control valves; therefore they should always be either fully open or fully closed to avoid damaging the sealing cups.

To ensure correct functioning, pressure and temperature specifications must be observed.

The handles are supplied loose with the ball valves.

2. TECHNICAL SPECIFICATIONS

2.1. GENERAL

2.1.1 Designation and symbol

Flange type ball valve KHMFF
sleeve type (short version)

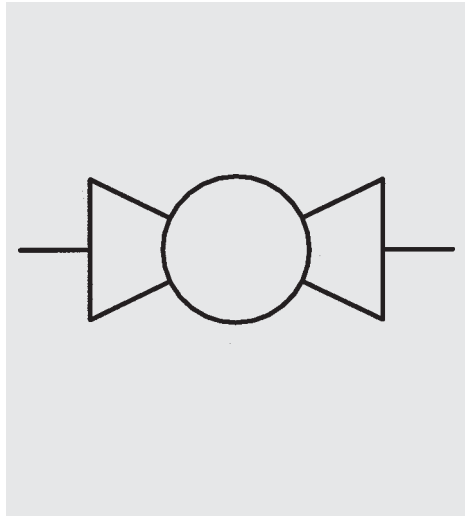

2.1.2 Model code (also order example)

KHMFF - 080 - PN016 - 8834 - 02 X

Designation

KHMFF = sleeve type flange ball valve
(short version F4) DN 65 - 100
and DN 125 reduced

KHMFF = sleeve type flange ball valve
(short version F5) DN 125 - 300

Nominal bore

Pressure range

to DIN 2401
see table 2.1.3

Materials

DN 65 - 100	PN 16	material code	8834
DN 65 - 100	PN 40	material code	10834
DN 65 - 125	PN 16 reduced	material code	8232
DN 125 - 150	PN 16	material code	8834
DN 125 - 150	PN 40	material code	10333
DN 200 - 300		material code	10333

Handle

02 = aluminium clamped handle, cranked (AK)
DN 65 - 100

05 = steel clamped handle, straight (SG)
DN 150 - 200

06 = steel clamped handle, cranked (SK)
DN 125 PN 40

16 = steel handle, cranked, fitted
reduced nominal bores DN 65 - 125

AM = mechanical drive DN 250 - 300
(worm gear with handwheel)

Series

(Determined by manufacturer)

When ordering, please quote stock number (see table 2.1.3).
Delivery for non-standard valves is longer and the price is higher.

2.1.3 Standard models

Type of connection/ sealing strip	Nominal bore and pressure range	Nominal bore DN	Length DIN 3202	Nominal pressure PN [bar]	Order no. = stock no.	Weight [kg]	
F4 (FTF, basic range 14)	Flange connection DIN 2501, Form E	KHMFF- 065-PN016 - 8834-02X	65	F4	16	701466	17.0
		KHMFF- 065-PN040 - 10834-02X	65	F4	40	701160	17.5
		KHMFF- 080-PN016 - 8834-02X	80	F4	16	702201	20.0
		KHMFF- 080-PN040 - 10834-02X	80	F4	40	701171	21.0
		KHMFF- 100-PN016 - 8834-02X	100	F4	16	702202	24.0
		KHMFF- 100-PN040 - 10834-02X	100	F4	40	701182	25.0
F4 (FTF, basic range 14)	Flange connection DIN 2501, Form C	KHMFF- 065-PN016 - 8232-16X	65 (50)*	F4	16	557421	10.5
		KHMFF- 080-PN016 - 8232-16X	80 (65)*	F4	16	557422	15.0
		KHMFF- 100-PN016 - 8232-16X	100 (80)*	F4	16	557423	18.0
		KHMFF- 125-PN016 - 8232-16X	125 (100)*	F4	16	557424	26.5
F5 (FTF, basic range 15)	Flange connection DIN 2501, Form C	KHMFF- 125-PN016 - 8834-06X	125	F5	16	702203	48.0
		KHMFF- 125-PN040 - 10333-06X	125	F5	40	558197	67.0
		KHMFF- 150-PN016 - 8834-05X	150	F5	16	702204	72.0
		KHMFF- 150-PN040 - 10333-05X	150	F5	40	703693	95.0
		KHMFF- 200-PN016 - 10333-05X	200	F5	16	703679	146.0
		KHMFF- 200-PN040 - 10333-05X	200	F5	40	703639	172.0
		KHMFF- 250-PN016 - 10333-AMX	250	F5	16	—	242.0
		KHMFF- 250-PN040 - 10333-AMX	250	F5	40	—	287.0
		KHMFF- 300-PN016 - 10333-AMX	300	F5	16	—	330.0
		KHMFF- 300-PN040 - 10333-AMX	300	F5	40	—	375.0

* = reduced nominal bore

2.1.4 Type of construction

Shut off device is a ball

2.1.5 Type of connection

Fixed flanges to DIN 2501,
Form E, DN 65 - 100,
length to DIN 3202 - F4 /
DIN-EN 558-1-FTF, basic range 14

Fixed flanges to DIN 2501,
Form C, DN 65 - 125,
length to DIN 3202 - F4 /
DIN-EN 558-1-FTF, basic range 14
(reduced)

Fixed flanges to DIN 2501,
Form C, DN 125 - 300,
length to DIN 3202 - F5 /
DIN-EN 558-1-FTF, basic range 15

2.1.6 Mounting position

Optional

2.1.7 Weight

See table 2.1.3

2.1.8 Flow direction

Optional

2.1.9 Ambient temperature

- 10 °C to + 80 °C

2.1.10 Materials

Material code 8834

Housing and flange
in cast iron (GG 25)
Spindle in steel
Ball in GG, hard-chromed
Ball seal in Teflon (PTFE)
Housing seal and control spindle
seal in Viton (FKM)

Material code 10834

Housing and flange in cast steel
(GS-C 25)
Spindle in steel
Ball in GG, hard-chromed
Ball seal in Teflon (PTFE)
Housing seal and control spindle
seal in Viton (FKM)

Material code 8232

Housing and flange in cast iron
(GG 25)

Spindle in steel

Ball in brass

Ball seal in Teflon (PTFE)

Housing seal and control spindle
seal in Perbunan (NBR) and
Teflon (PTFE)

Material code 10333

Housing and flange in
cast steel (GS-C 25)

Spindle in steel

Ball in stainless steel

Ball seal in Teflon (PTFE)

Housing seal and control spindle
seal in Teflon (PTFE)

Material code 10333
(DN 250 - 300)

Housing and flange in
cast steel (GS-C 25)

Spindle in stainless steel

Ball in stainless steel with top and
bottom bearing locators

Ball seal in Teflon (PTFE)

Housing seal and control spindle
seal in Teflon (PTFE).

Aluminium handle, cranked
red anodised DN 65 - 100

Steel handle, cranked
zinc-plated and PVC-coated
DN 65 - 125 reduced

Steel handle, straight
painted DN 150 - 200

Steel handle, cranked
painted DN 125

Worm gear with handwheel
DN 250 - 300

2.2. HYDRAULIC DETAILS

2.2.1 Nominal pressure

PN 16 bar and PN 40 bar

2.2.2 Operating fluids

Mineral oil to DIN 51524 Part 1
and Part 2
(other media on request)

2.2.3 Temperature of operating fluid

- 10 °C to + 80 °C

3. DIMENSIONS

3.1. HANDLE

Straight handle

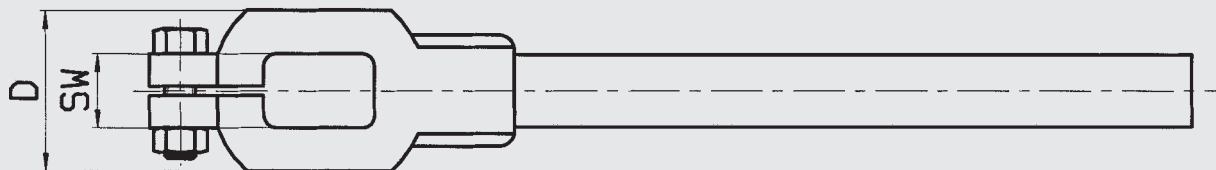
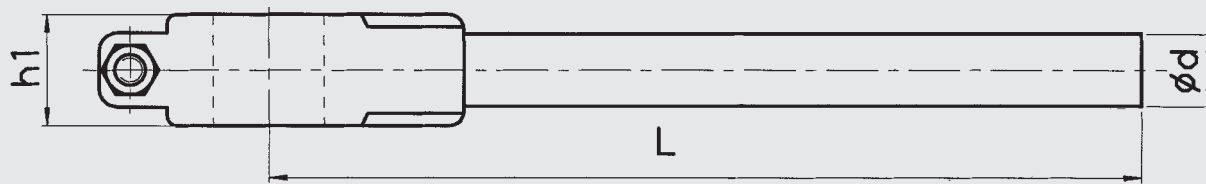

L	D	ød	h1	SW	Ball valve nominal bore	Type	Order no. = stock no.
850	56	33	46	32	150 - 200	05 (SG)	-

Cranked handle

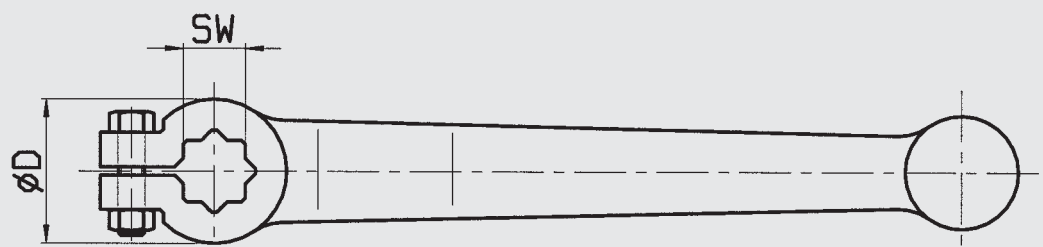
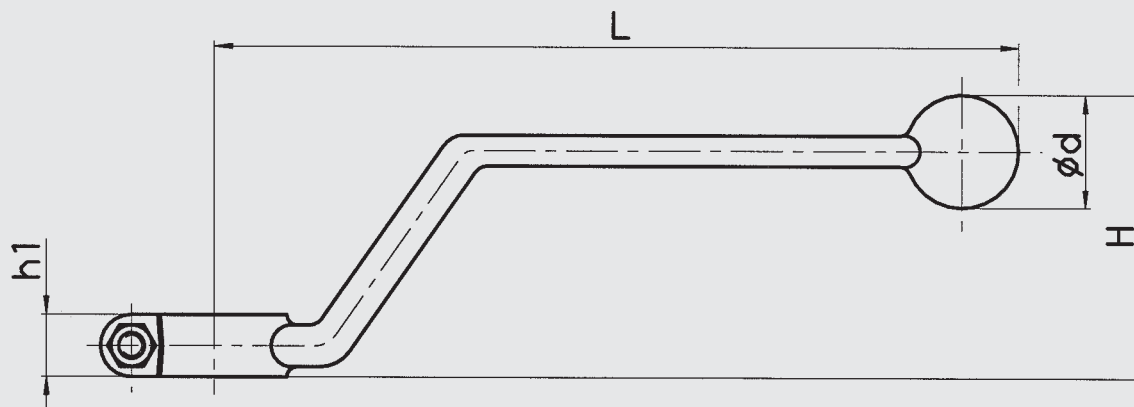

L	øD	ød	h1	H	SW	Ball valve nominal bore	Type	Order no. = stock no.
360	44	32	18	61	22	65 - 100	02 (AK)	281604
715	56	27	30	60	25.5	125	06 (SK)	-

3.1.1 Notes on assembly

The clamped handle is pushed onto the square end of the ball valve spindle and clamped to the square by means of a screw through the end of the handle.

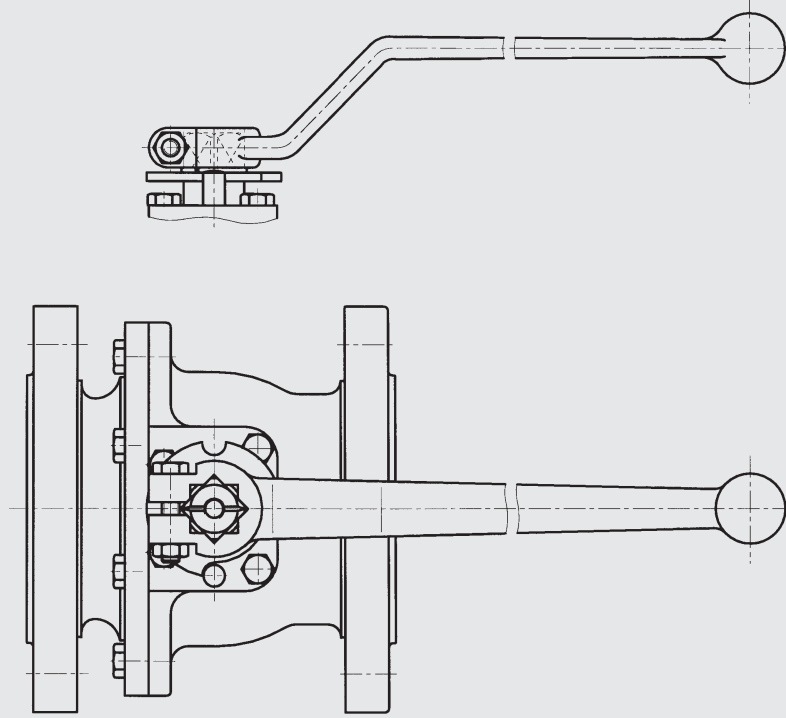

The handles can be displaced by 45° DN 65 - 100.
(Except for DN 65 - 125 reduced and DN 125 - 200 with fixed handle position)

SW 22

Torque rating

10 Nm

3.2. BALL VALVE KHMFF (reduced)

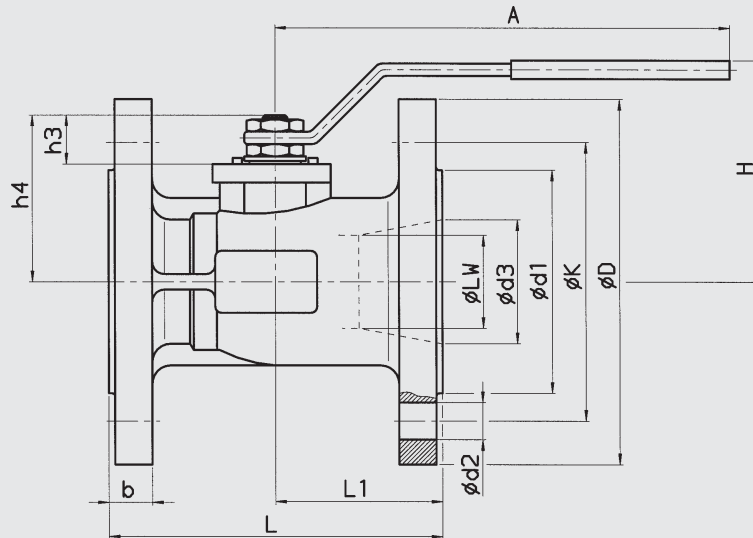

Type	Pressure range	LW	A	L	L1	D	d1	d2	d3	K	b	H	h3	h4	Z*
KHMFF - 065	16	50*	250.5	170	85	185	122	18	65	145	18	109	23.5	86	4
KHMFF - 080	16	64*	320	180	90	200	138	18	80	160	20	127.5	28.5	104.5	4/8
KHMFF - 100	16	76*	320	190	95	220	158	18	100	180	20	137	28.5	114	8
KHMFF - 125	16	95*	380	200	100	250	188	18	125	210	22	157.5	32.5	137	8

* = reduced nominal bore
Z* = number of fixing holes

KHMFF (DN 65-300)

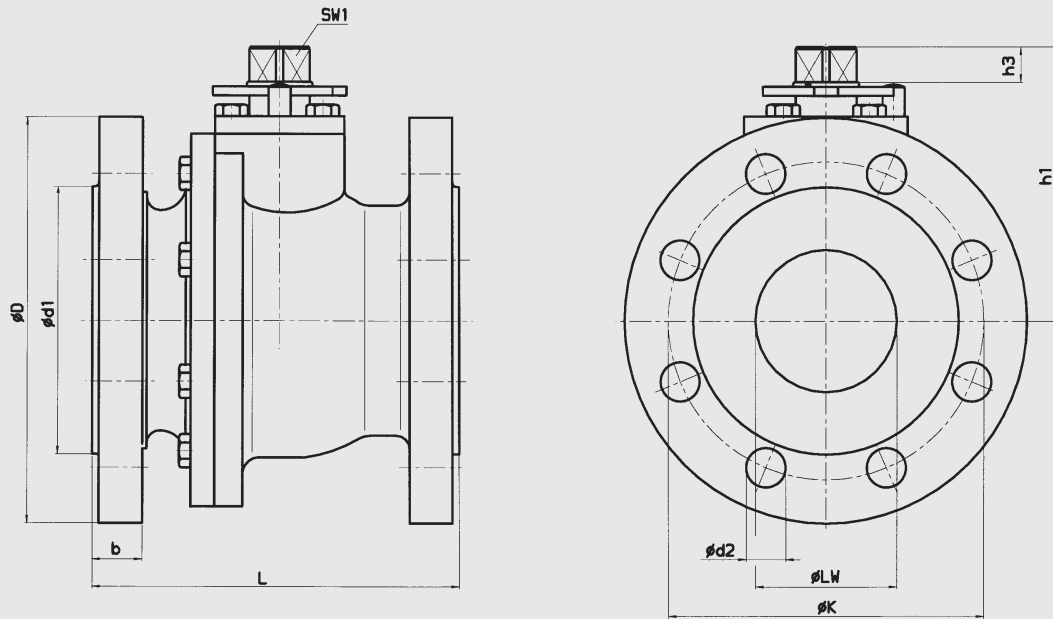

Type	Pressure range	LW	L	D	d1	d2	K	b	h1	h3	SW 1	Z*
KHMFF - 065	10 - 16	65	170	185	122	18	145	18	124	16	22	4
KHMFF - 065	25 - 40	65	170	185	122	18	145	22	124	16	22	8
KHMFF - 080	10 - 16	80	180	200	138	18	160	20	134	16	22	8
KHMFF - 080	25 - 40	80	180	200	138	18	160	24	134	16	22	8
KHMFF - 100	10 - 16	100	190	220	158	18	180	20	148.5	16	22	8
KHMFF - 100	25 - 40	100	190	235	162	22	190	24	148.5	16	22	8
KHMFF - 125	10 - 16	125	325	250	188	18	210	22	265	30	25.5	8
KHMFF - 125	25 - 40	125	325	270	188	26	220	26	265	30	25.5	8
KHMFF - 150	10 - 16	150	350	285	212	22	240	22	297.5	41.5	32	8
KHMFF - 150	25 - 40	150	350	300	218	26	250	28	297.5	41.5	32	8
KHMFF - 200	16	200	400	340	268	22	295	24	335	41.5	32	12
KHMFF - 200	40	200	400	375	285	30	320	34	335	41.5	32	12
KHMFF - 250	16	250	450	405	320	26	355	26	390	51	36	12
KHMFF - 250	40	250	450	450	345	33	385	38	390	51	36	12
KHMFF - 300	16	300	500	460	378	26	410	28	425	51	36	12
KHMFF - 300	40	300	500	515	410	33	450	42	425	51	36	16

Z* = number of fixing holes

4. NOTE

The information in this brochure relates to the operating conditions and applications described.

For applications or operating conditions not described, please contact the relevant technical department.

Subject to technical modifications.