

SAE Flanged Ball Valves

KHB-F3/6 / KHM-F3/6

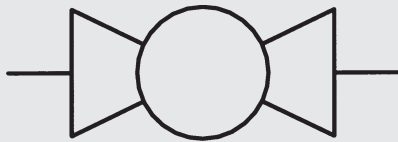

up to 400 bar
up to DN 50

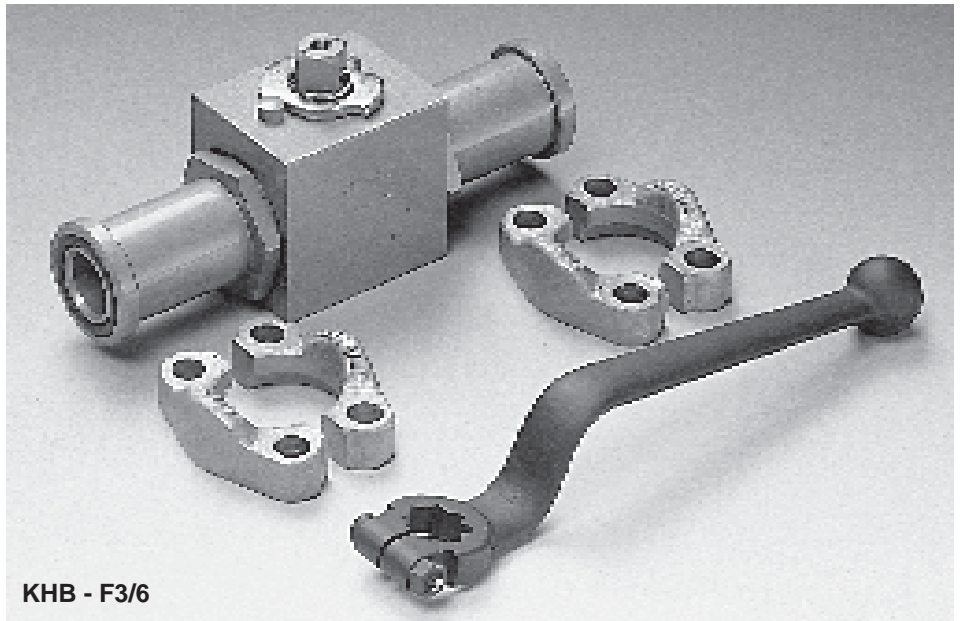

KHB - F3/6

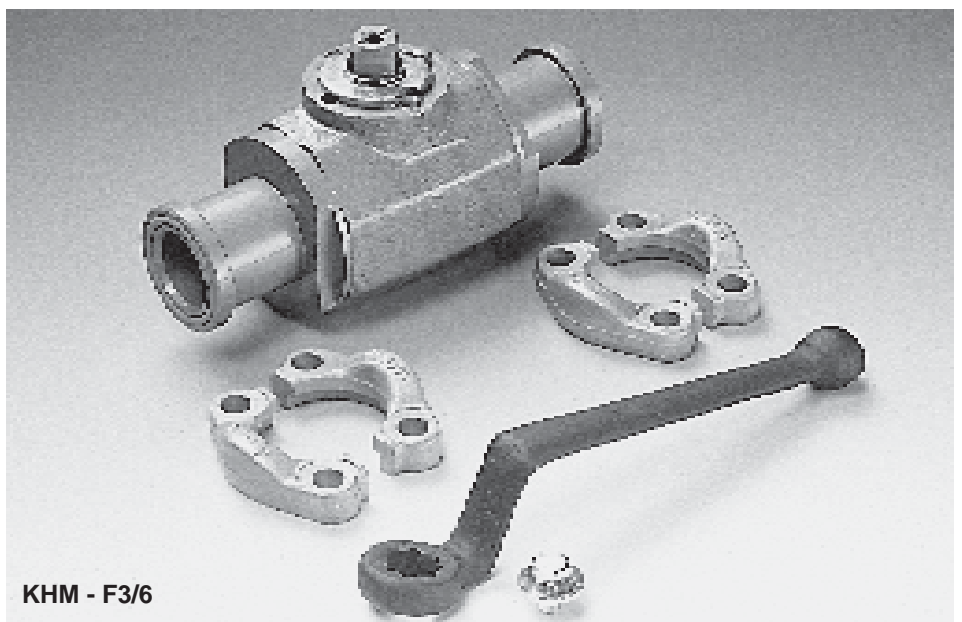

KHM - F3/6

1. DESCRIPTION

1.1. GENERAL

According to DIN-ISO 1219, 2/2-way SAE flanged ball valves are units which serve to shut off the flow of an operating medium in both directions.

They are available in two models:

- Block type (KHB) - DN 16 - 25
- Sleeve type (KHM) - DN 32 - 50

These ball valves have the following advantages:

- Visual indication of the switching position by means of a slot on the control spindle
 - Switching limited by means of stop pin and stop disc
 - No glands, therefore no manual re-adjustment of seals required
 - Sealing principle with floating ball, sealing on the outlet side
 - Full flow passage for unrestricted flow of medium
 - Easy operation
 - Easy fitting due to SAE split flanges
 - O-ring sealing on both sides
 - Surface phosphate-plated
- SAE flanged ball valves are available in stainless steel.

Flanged ball valves:
see brochure no. E 5.502../..

On request we can supply other models to cover nearly all applications, for example, for aggressive or gaseous media, as well as quality test certificates to DIN 55350, Part 18.

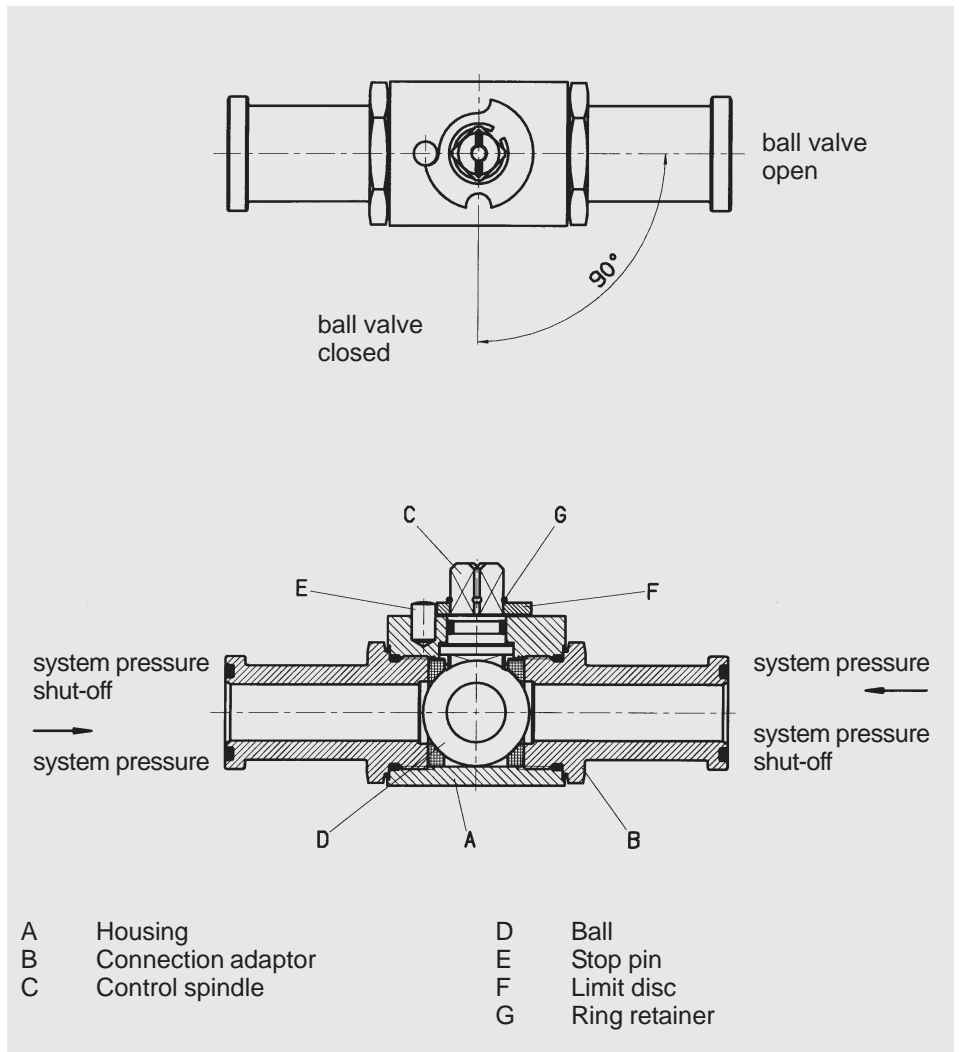

1.2. FUNCTION

Turning the control spindle moves the ball from the open to the closed switching position. The system pressure pushes the ball against the non-pressurised side of the sealing cup and shuts off the flow leakage-free.

1.3. APPLICATION

SAE flanged ball valves KHB/M - F3 / F6 are used to shut off flow in hydraulic circuits.

Areas of application are for example:

- Pipeline construction
- Machine tools
- System engineering
- Off-shore sector

1.4. NOTES

Ball valves are not designed to be used as flow control valves; therefore they should always be either fully open or fully closed, to avoid damaging the sealing cups.

To ensure correct functioning, the pressure and temperature specifications must be observed.

The permissible operating pressure of the ball valve and the flange connection (split flanges) must be taken into account.

The O-rings on the connection side and the SAE split flanges are supplied with the ball valve.

The handles are supplied loose with the ball valves.

2. TECHNICAL SPECIFICATIONS

2.1. GENERAL

2.1.1 Designation and symbol

Block type ball valve KHB - F3

Block type ball valve KHB - F6

Sleeve type ball valve KHM - F3

Sleeve type ball valve KHM - F6

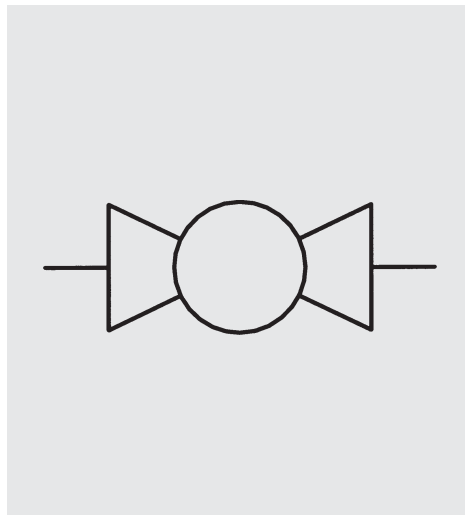

2.1.2 Model code (also order example)

KHB - 20 - F3 - 11141 - 02 X

Designation

KHB = block type ball valve DN 16 - 25
KHM = sleeve type ball valve DN 32 - 50

Nominal bore

Type of SAE flange

Materials

Housing, connection adaptor and control spindle (steel)

Ball (steel)

Sealing cups (POM)

Control spindle seal and connection seal, Viton (FKM)

SAE split flanges (steel)

Material code

1

1

1

4

1

Handle

02 = aluminium clamped handle, cranked (AK)

06 = steel bolt-on handle, cranked (SK)

Series

(Determined by manufacturer)

Please quote stock no. when ordering (see table 2.1.3).
Delivery for non-standard valves is longer and the price is higher.

2.1.3 Standard models

Type of connection	SAE size	Nominal bore / type	Nominal bore DN	Nominal pressure PN [bar]	Order no. =stock no.	Weight [kg]
Split flange connection to ISO 6162, table 1 (SAE J 518 c)	1/2 "	KHB- 16-F3 -11141-02X	16	350	3018376	1.1
	3/4 "	KHB- 16/20-F3 -11141-02X	16 *	350	701199	1.6
	3/4 "	KHB- 20-F3 -11141-02X	20	350	701522	2.1
	1 "	KHB- 25-F3 -11141-02X	25	350	701523	2.8
	1 1/4 "	KHM- 32-F3 -11141-06X	32	275	851341	4.7
	1 1/2 "	KHM- 40-F3 -11141-06X	40	210	701486	6.9
	2 "	KHM- 50-F3 -11141-06X	50	210	701507	9.7
Split flange connection to ISO 6162, table 2 (SAE J 518 c)	1/2 "	KHB- 16-F6 -11141-02X	16	400	3018375	1.2
	3/4 "	KHB- 16/20-F6 -11141-02X	16 *	400	703964	1.9
	3/4 "	KHB- 20-F6 -11141-02X	20	350	703965	2.5
	1 "	KHB- 25-F6 -11141-02X	25	350	702462	3.5
	1 1/4 "	KHM- 32-F6 -11141-06X	32	350	701500	6.4
	1 1/2 "	KHM- 40-F6 -11141-06X	40	350	701503	9.7
	2 "	KHM- 50-F6 -11141-06X	50	350	701506	14.7

* = reduced nominal bore

- 2.1.4 **Type of construction**
Shut off device is a ball
- 2.1.5 **Type of connection**
SAE split flanges to ISO 6162, table 1 and 2 (SAE J 518 c)
- 2.1.6 **Mounting position**
Optional
- 2.1.7 **Weight**
See table 2.1.3
- 2.1.8 **Flow direction**
Optional
- 2.1.9 **Ambient temperature**
- 10 °C to + 80 °C

- 2.1.10 **Materials**
Housing, connection adaptors and control spindle in steel, surface phosphate-plated
SAE split flanges in steel, surface zinc-plated
Ball in steel, hard chromed
Ball seal in high quality synthetic material (POM)
Soft seals in Viton (FKM)
Cranked clamped handle SW 12 - 14 in aluminium, red anodised
Cranked bolt-on handle SW 17 in steel, zinc-plated

2.2. HYDRAULIC DETAILS

- 2.2.1 **Nominal pressure**
PN 210 bar to PN 400 bar (see table 2.1.3)
- 2.2.2 **Operating fluids**
Mineral oil to DIN 51524 Part 1 and Part 2 (other media on request)
- 2.2.3 **Temperature of operating fluid**
- 10 °C to + 80 °C

3. DIMENSIONS

3.1. HANDLE

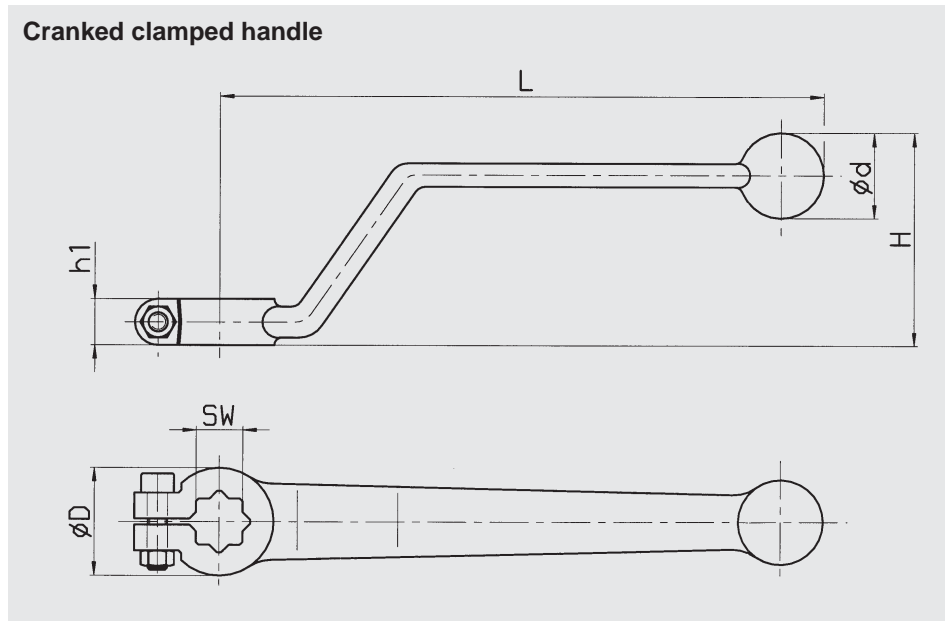

L	H	ØD	Ød	h1	SW	Model	Order no.= stock no.	Weight [kg]
163	52	28	22	12	12	02 (AK)	270381	0.072
183	54	32	24	12	14	02 (AK)	270382	0.097

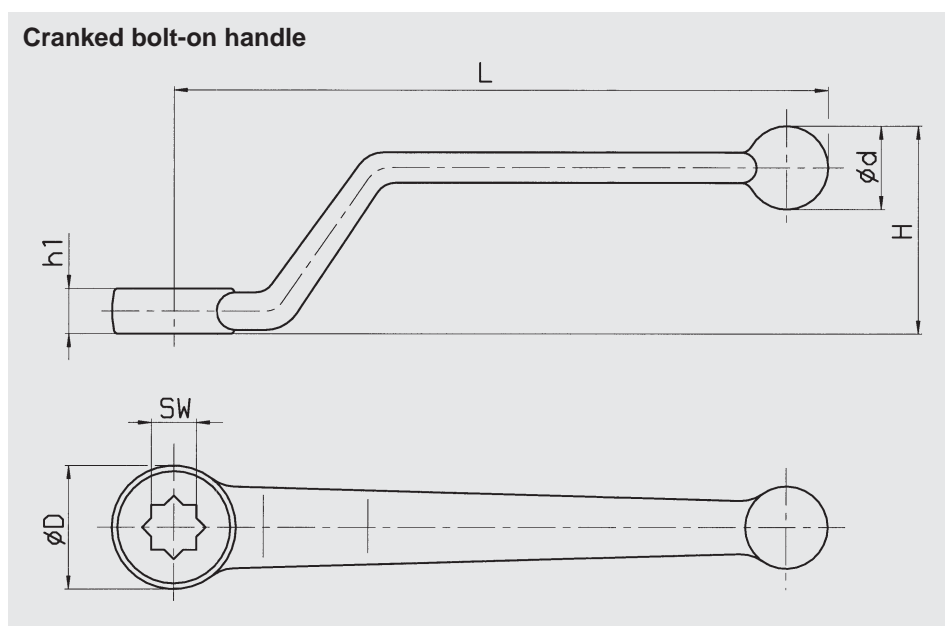

L	H	ØD	Ød	h1	SW	Model	Order no.= stock no.	Fixing bolt Order no.= stock no.	Weight [kg]
228	80	34	20	14	17	06 (SK)	273662	638600	0.342

3.1.1 Notes on assembly

The clamped handle is pushed onto the square end of the ball valve spindle and clamped to the square by means of a screw through the end of the handle.

Clamped handle

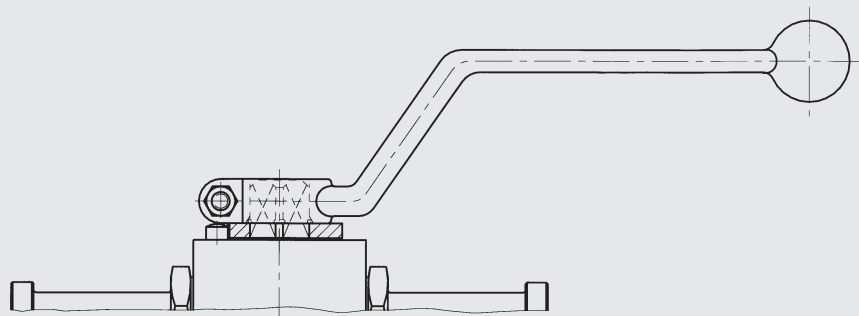

torque rating

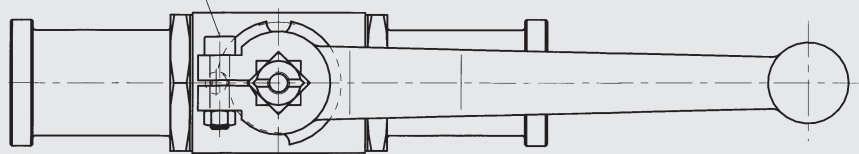

	SW 12	SW 14
	M 5 x 20	M 6 x 30
Torque rating	3 Nm	5 Nm

The bolt-on handle is screwed to the ball valve control spindle by means of a fixing bolt from above.

Bolt-on handle

fixing bolt

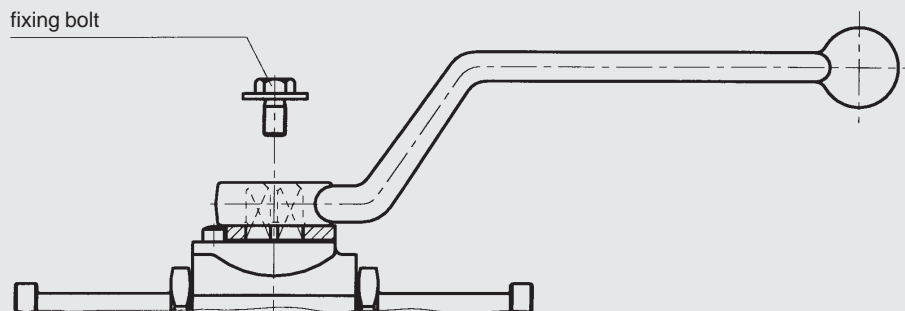

torque rating

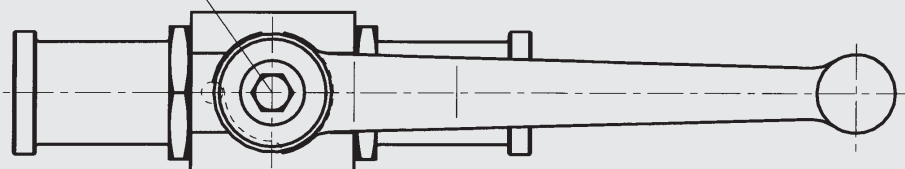

	SW 17
Fixing bolt	M 8 x 16
Torque rating	5 Nm

Both types of handle can be displaced by 45°.

3.2. SAE FLANGED BALL VALVE
KHB

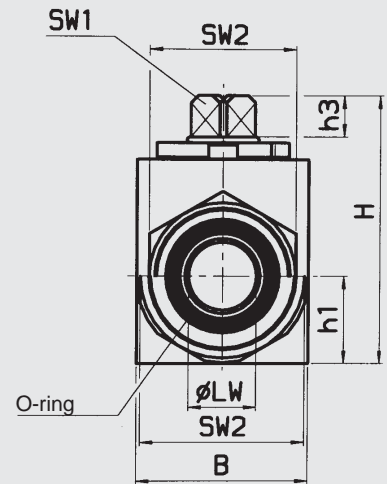
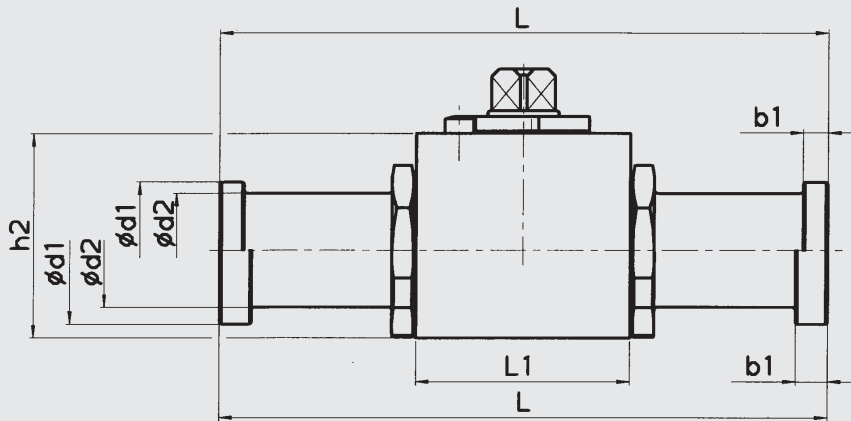

KHM

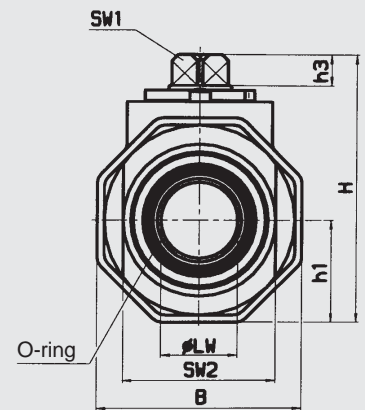
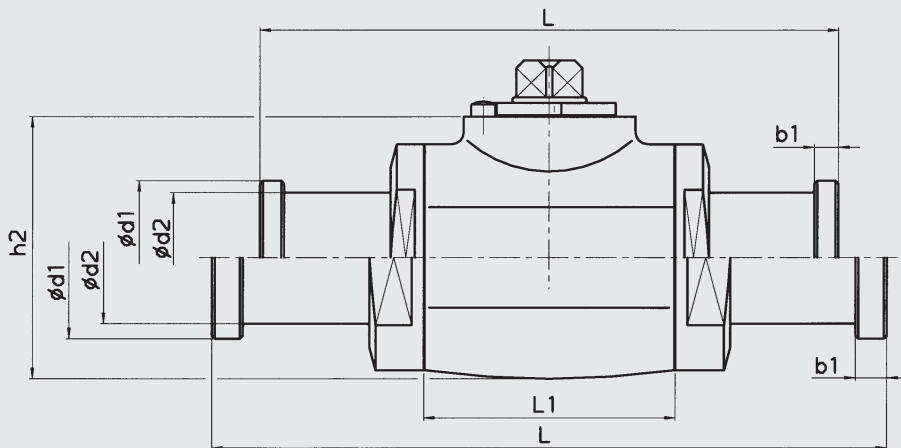

SAE split flange

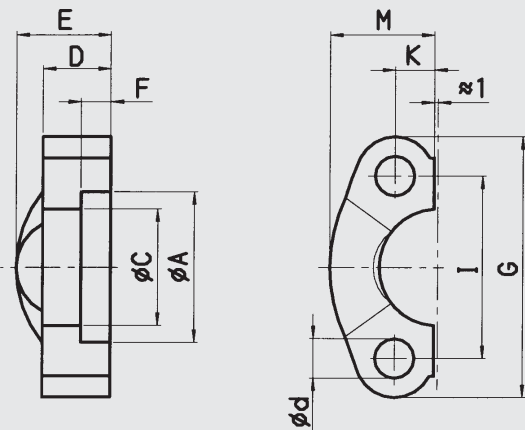

KHB / KHM - F3

Type	SAE size	DN	LW	L	L1	H	h1	h2	h3	B
KHB-16-F3	1/2 "	16	13	151	47	62	19	45	11	38
KHB-16/20-F3	3/4 "	16	16*	170	47	62	19	45	11	38
KHB-20-F3	3/4 "	20	19	170	60	75	24.5	57	11	48
KHB-25-F3	1 "	25	25	176.5	65	82	28.5	64	11	57
KHM-32-F3	1 1/4 "	32	30	191.4	83.4	103	37.5	85	12	75
KHM-40-F3	1 1/2 "	40	38	231	91	114	42.5	96	12	85
KHM-50-F3	2 "	50	48	234	100	131.5	52.5	112.5	12	105

Type	b1	d1	d2	SW 1	SW 2	O-ring
KHB-16-F3	6.8	30.2	24	12	32	18.66 x 3.53
KHB-16/20-F3	6.8	38.1	31.5	12	32	24.99 x 3.53
KHB-20-F3	6.8	38.1	31.5	14	41	24.99 x 3.53
KHB-25-F3	8	44.45	38	14	50	32.92 x 3.53
KHM-32-F3	8	50.8	43	17	60	37.92 x 3.53
KHM-40-F3	8	60.35	50	17	70	47.22 x 3.53
KHM-50-F3	9.6	71.4	62	17	80	56.74 x 3.53

SAE split flange - F3

Type	A	C	D	E	F	M	K	I	G	d
KHB-16-F3	31	24.3	13	19	6.2	21.8	8	38.1	54	8.8
KHB-16/20-F3	38.9	32.2	14	22	6.2	24.9	10	47.6	65	10.5
KHB-20-F3	38.9	32.2	14	22	6.2	24.9	10	47.6	65	10.5
KHB-25-F3	45.3	38.5	16	22	7.5	28.2	12	52.4	70	10.5
KHM-32-F3	51.6	43.7	14	24	7.5	35.3	14	58.7	80	12
KHM-40-F3	61.1	50.8	16	25	7.5	40.1	17	69.9	94	13.5
KHM-50-F3	72.3	62.8	16	26	9	47.2	21	77.8	102	13.5

* = reduced nominal bore

KHB / KHM - F6

Type	SAE size	DN	LW	L	L1	H	h1	h2	h3	B
KHB-16-F6	1/2 "	16	13	151	47	62	19	45	11	38
KHB-16/20-F6	3/4 "	16	16*	170	47	62	19	45	11	38
KHB-20-F6	3/4 "	20	19	170	60	75	24.5	57	11	48
KHB-25-F6	1 "	25	25	198.5	65	82	28.5	64	11	57
KHM-32-F6	1 1/4 "	32	30	223.4	83.4	103	37.5	85	12	75
KHM-40-F6	1 1/2 "	40	38	281	91	114	42.5	96	12	85
KHM-50-F6	2 "	50	48	315	100	131.5	52.5	112.5	12	105

Type	b1	d1	d2	SW 1	SW 2	O-ring
KHB-16-F6	7.8	31.8	24	12	32	18.66 x 3.53
KHB-16/20-F6	8.8	41.3	32	12	32	24.99 x 3.53
KHB-20-F6	8.8	41.3	32	14	46	24.99 x 3.53
KHB-25-F6	9.5	47.6	38	14	50	32.92 x 3.53
KHM-32-F6	10.3	54	44	17	60	37.92 x 3.53
KHM-40-F6	12.6	63.5	51	17	70	47.22 x 3.53
KHM-50-F6	12.6	79.4	67	17	80	56.74 x 3.53

SAE split flange - F6

Typ	A	C	D	E	F	M	K	I	G	d
KHB-16-F6	32.5	24.6	16	22	7.2	22.6	8	40.5	57	8.8
KHB-16/20-F6	42	32.5	19	28	8.2	29	11	50.8	72	10.5
KHB-20-F6	42	32.5	19	28	8.2	29	11	50.8	72	10.5
KHB-25-F6	48.4	38.9	24	33	9	33.8	13	57.2	81	13
KHM-32-F6	54.8	44.5	27	38	9.8	37.6	15	66.6	96	15
KHM-40-F6	64.3	51.6	30	43	12	46.5	17	79.3	113	17
KHM-50-F6	80.2	67.6	37	52	12	55.9	21	96.8	134	21

4. SPARE PARTS

KHB, DN 16 - 25

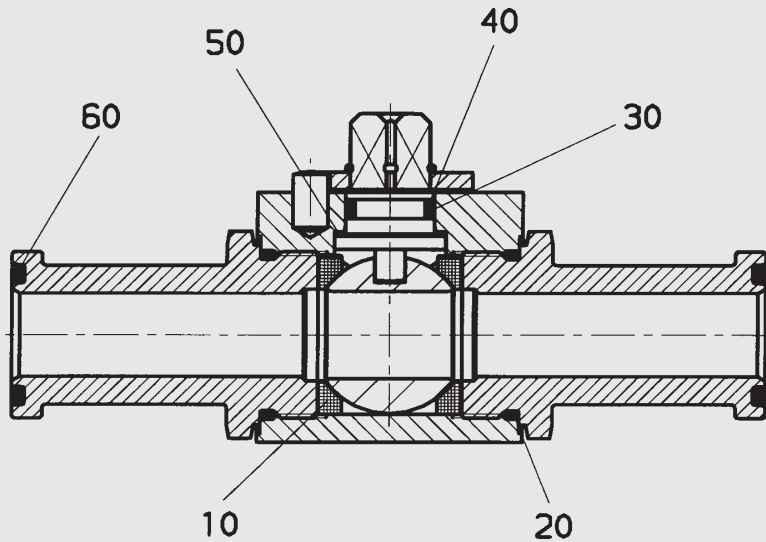

KHM, DN 32 - 50

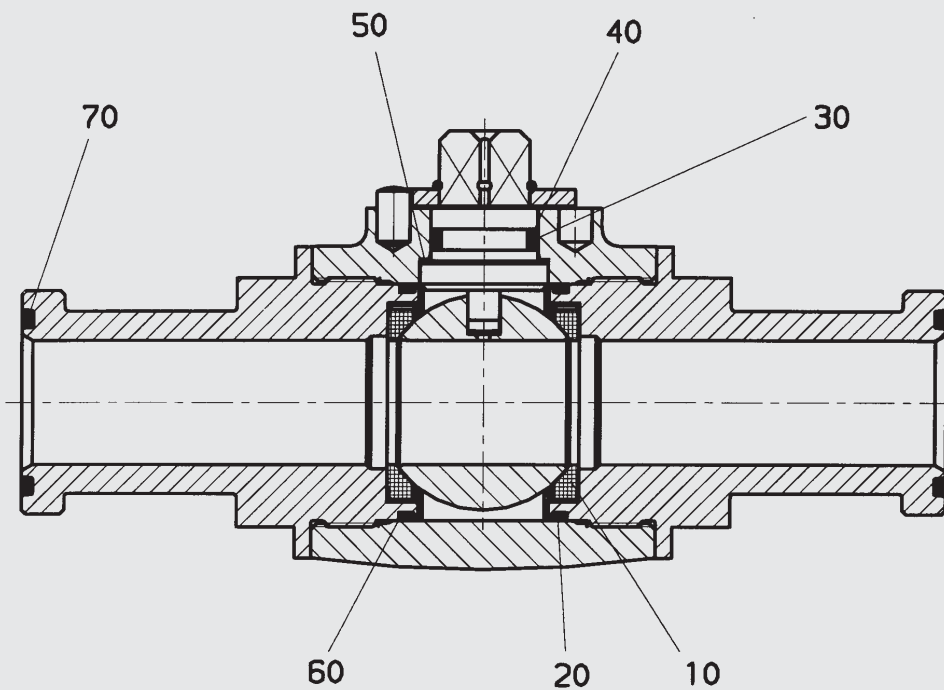

Seal kit	Order no. = stock no.
DN 16	3046470
DN 16/20	554819
DN 20	703153
DN 25	703117
DN 32	703142
DN 40	703030
DN 50	703031

The parts indicated by numbers on the above drawings are contained in the seal kit.

5. NOTE

The information in this brochure relates to the operating conditions and applications described. For applications or operating conditions not described, please contact the relevant technical department. Subject to technical modifications.