

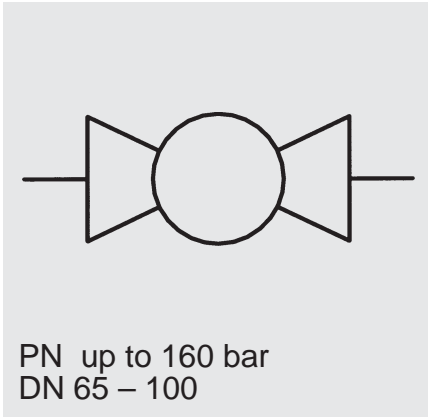

SAE Fixed Flange Ball Valves

KHF3



Model code
(also order example)

KHF3 65 1114 05 X G UNC

Designation

KHF3 = fixed flange ball valve DN 65 – 100

Nominal width

Material codes

1	1	1	4
Steel	Steel	Synthetic material (POM)	Viton (FKM)

Housing			
Housing flange	Ball	Ball seal	Soft seal
Control spindle			

(other material combinations available on request)

Handle

05 = steel handle, straight (supplied loose)

Serial number

(Determined by manufacturer)

Surface protection

... = phosphate-plated (no details required)
G = yellow zinc-plated

Type

... = metric connection thread (no details required)
UNC = UNC connection thread

Dimensions

KHF3

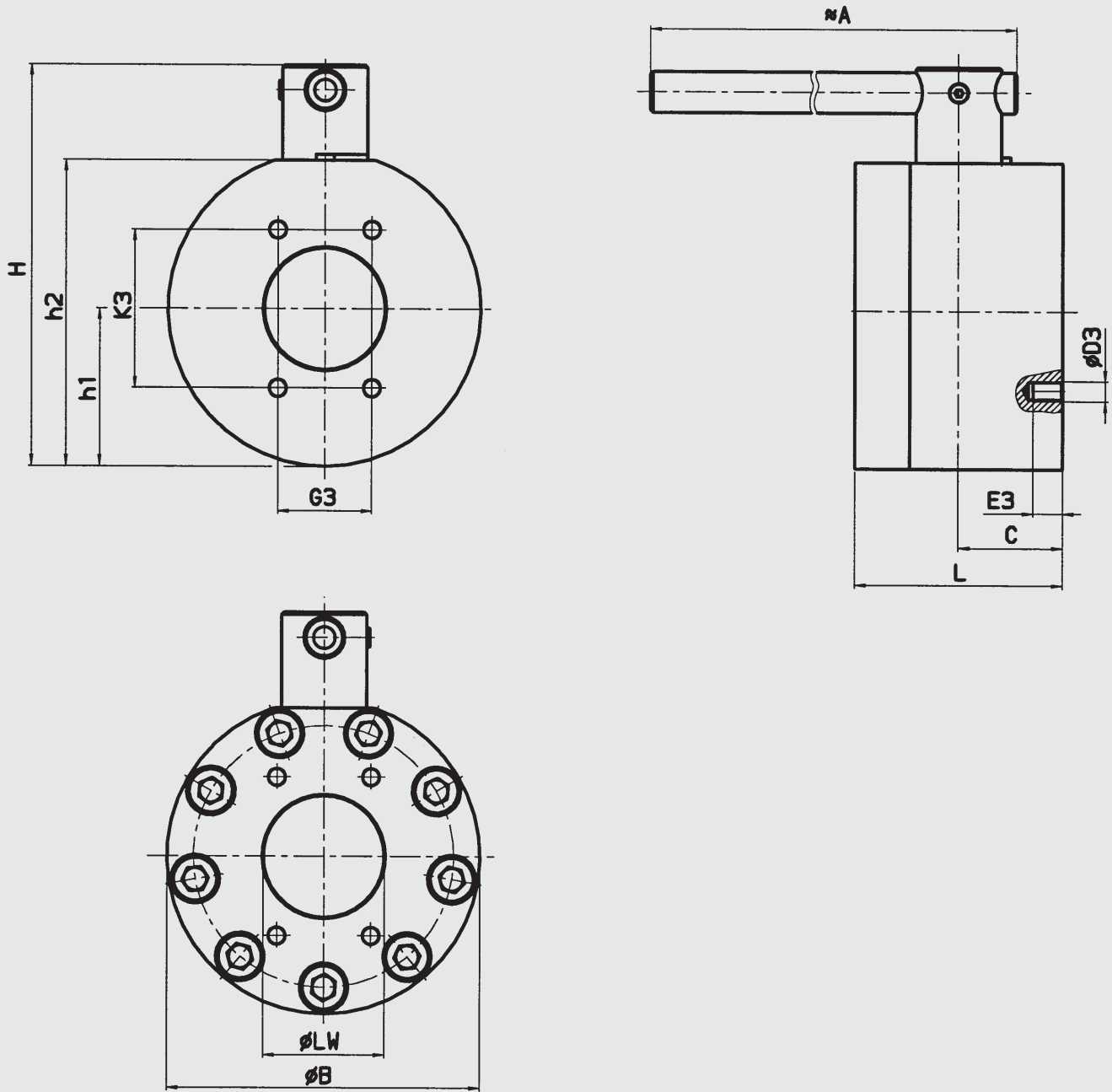

Type of connection			Housing dimensions								PN [bar]	Weight [kg]
	DN	SAE-Size	LW	L	C	H	h1	h2	B	A		
Fixed flange to ISO 6162 table 1 (SAE J 518 c) SAE - F3	65	2 1/2"	63	150	75	274	99	193	198	800	160	33.3
	80	3"	76	140	70	290	105	209	210	800	100	40.0
	100	4"	100	170	85	332	129	251	258	800	25	59.5

DN	SAE-size	Connection dimensions - metric				Connection dimensions - UNC			
		K3	G3	D3	E3	K3	G3	D3	E3
65	2 1/2"	88.9	50.8	M12	20	88.9	50.8	1/2-13 UNC	20
80	3"	106.4	61.9	M16	24	106.4	61.9	5/8-11 UNC	24
100	4"	130.2	77.8	M16	24	130.2	77.8	5/8-11 UNC	24

Technical specifications

Mounting position:	optional
Ambient temperature:	-10 °C to +80 °C
Nominal pressure:	up to PN 160 bar (see pressure range)
Operating fluids:	mineral oil to DIN 51524 Part 1 and Part 2 (other media on request)
Temperature of operating fluid:	-10 °C to +80 °C
Spare parts:	Seal kits available on request
Accessories:	All ball valves can be supplied with the following options: Actuator Limit controls Lock

Note

The information in this brochure relates to the operating conditions and applications described.
For applications or operating conditions not described, please contact the relevant technical department.
Subject to technical modifications.