

**MOBILE OIL / AIR COOLERS
NEW COMPACT DESIGN
WITH HYDRAULIC MOTOR
AND HIGH COOLING
PERFORMANCE**

Application

These coolers are designed specifically for mobile hydraulic applications where high performance and efficiency are required and physical size is minimised to allow easy installation. Typical applications include mobile cranes, concrete mixers and pump trucks, road paving machines & transmission cooling.

OK-ELH Product Features

These coolers use a combination of high performance cooling elements and hydraulic motors to give long trouble free operation in arduous mobile hydraulic applications.

The compact design allows the coolers to fit most equipment and provide the highest cooling performance in heat dissipation whilst minimising space required.

- Cooling range 2-140 kW at ΔT 40 °C
- Hydraulic Motors from 6.3 to 22 cc
- Simple disassembly of components

Oil/Air Cooler Units

Mobile application and
Hydraulic motor
OK ELH Type



Test procedure certified following EN 1048

OIL/AIR COOLER

DESCRIPTION

GENERAL

In hydraulic systems energy is transformed and transmitted. During this transformation and transmission losses occur, i.e. mechanical and hydraulic energy is converted into heat. It is the function of the cooler to dissipate this heat.

ADVANTAGES OF THE OIL/AIR COOLERS

- Environmentally friendly: exchange between air and oil not possible
- For commissioning only the existing hydraulic power can be used.
- Low operating costs, no additional cooling circuit necessary for the cooling medium, i.e. air

CONSTRUCTION

Oil/air cooler units consists of the (1) metal housing, (2) motor, (3) axial fan, (4) heat exchanger, (5) finger grid, (6) support and (7) feet. The oil connections are external.

ELH 2-5

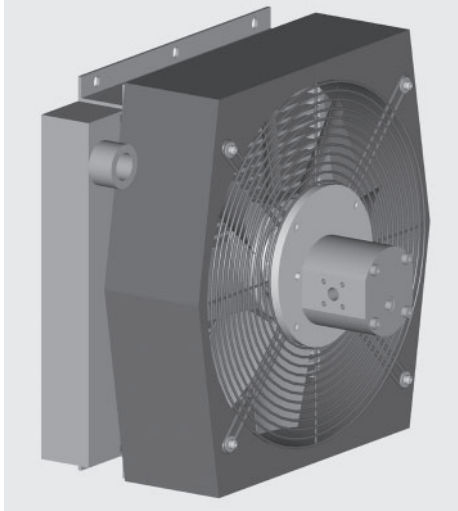

ELH 2-5

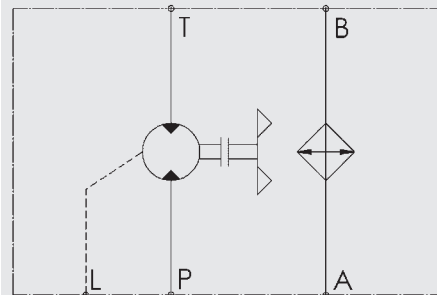

ELH 6-11

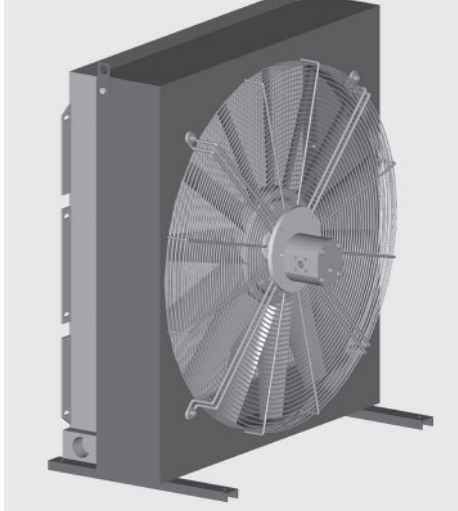

ELH 6-11

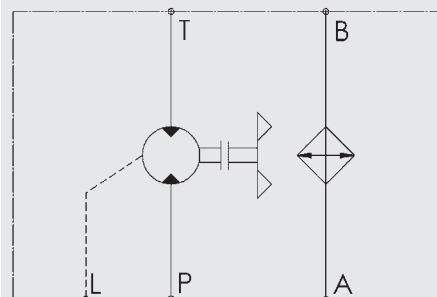

ELH 2-5

ELH 6-11

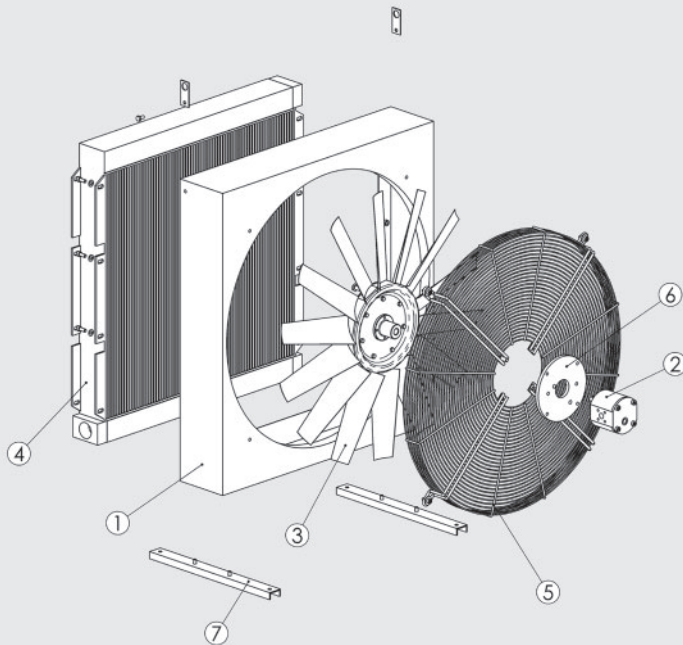
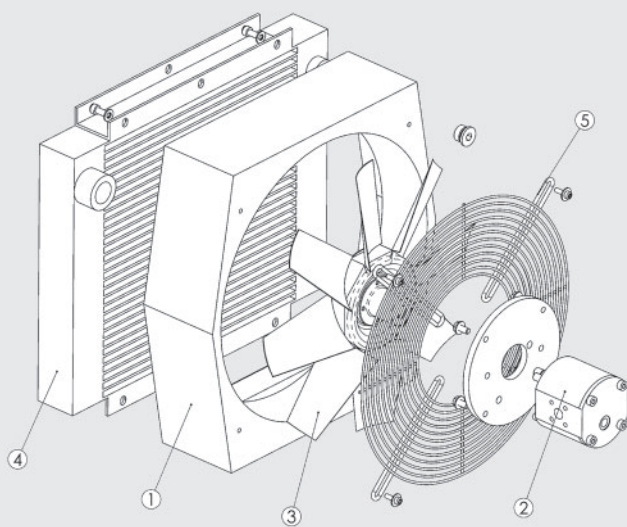

COOLER SELECTION

Designation:

P_v = Power loss [kW]

P_{01} = Specific cooling capacity [kW/°C]

V = Tank contents [l]

ρ_{oil} = Density of the oil [kg/l]
for mineral oil: 0.915 kg/l

C_{oil} = Specific heat capacity [kJ/kgK]
for mineral oil 1.88 kJ/kgK

ΔT = Temperature increase in the system [°C]

t = Operating time [min]

T_1 = Desired oil temperature [°C]

T_3 = Ambient temperature [°C]

Example 1:

Measurement of the power loss on existing units and machinery. For this method the temperature increase of the oil is measured over a certain period. The power loss can be calculated from the temperature increase.

Parameters:

The oil temperature increases from 20 °C to 45 °C over 15 minutes.

The tank contains 100 l.

Heat to be dissipated:

$$P_v = \frac{\Delta T \times c_{oil} \times \rho_{oil} \times V}{t \times 60} \quad [\text{kW}]$$

$$P_v = \frac{25 \times 1.88 \times 0.915 \times 100}{15 \times 60} = 4.78 \quad [\text{kW}]$$

Cooler selection:

– Desired oil temperature: 60 °C
– Ambient temperature air: 30 °C

$$P_{01} = \frac{P_v}{T_1 - T_3} \quad [\text{kW/°C}]$$

$$P_{01} = \frac{4.78}{60 - 30} = 0.159 \quad [\text{kW/°C}]$$

A 10% safety margin is recommended to allow for element contamination, and therefore the specific power is:

$$P_{01} \times 1.1 = 0.175 \text{ kW/°C.}$$

The power loss 0.175 kW/°C must be dissipated by an oil cooler.

Suggestion:

–Cooler OK-ELH2 - 3000 rpm,
 $P_{01} = 0.20 \text{ kW/°C}$ at 80 l/min

Example 2:

The power loss can also be estimated: With unrestricted flow approx. 15 to 20% of the drive power. With restricted flow up to 30% of the drive power.

1. TECHNICAL DETAILS

1.1. TABLE OF TECHNICAL SPECIFICATIONS

Type of cooler	Oil flow at 1.5 bar pressure drop [l/min]	Operating speed range [rpm]	Motor displacement [cm³/r]	Motor max. pressure [bar]	Continuous motor operating pressure [bar]	Min. oil motor pressure Δp^* at max. speed [bar] (at 34 cts)	Motor oil flow at 1500 rpm [l/min]	Noise level at 1000 rpm [dB(A)] (at 1 m distance)	Max. operating pressure [bar]	Max. oil temperature [°C]	Max. Viscosity [mm²/s]	Weight [kg]
ELH2	110	1000 3000	6.3-14 22	300-300 200	250-250 150	20	10.5-23 36.6	69	16	130	2000	11
ELH3	110	1000 3000	6.3-14 22	300-300 200	250-250 150	20	10.5-23 36.6	69	16	130	2000	13
ELH4	150	1000 3000	6.3-14 22	300-300 200	250-250 150	50-30 20	10.5-23 36.6	70	16	130	2000	18
ELH5	190	1000 3000	6.3-14 22	300-300 200	250-250 150	70-30 20	10.5-23 36.6	70	16	130	2000	24
ELH6	230	1000 3000	6.3-14 22	300-300 200	250-250 150	150-70 50	10.5-23 36.6	70	16	130	2000	43
ELH8	300	1000 2800	6.3-14 22	300-300 200	250-250 150	200-80 60	10.5-23 36.6	76	16	130	2000	67
ELH9	300	1000 2200	14 22	300 200	250 150	130 90	23 36.6	78	16	130	2000	85
ELH10	300	1000 1800	14 22	300 200	250 150	230 130	23 36.6	82	16	130	2000	110
ELH11	300	1000 1600	14 22	300 200	250 150	250 150	23 36.6	83	16	130	2000	155

– Mounting position: all positions possible

– For direction of rotation see arrow on cooler housing

– Cooling fluid

Mineral oil to DIN 51524

For other fluids, please contact our sales/technical department

– Hydraulic motor operating characteristics:

The hydraulic motors are reversible with drain port.

The motor oil flow Q can be calculated at nominal motor oil operating pressure as follows

$$Q = \frac{V_g \times n}{10^3 \times \eta_{vol}} \quad [\text{l/min}]$$

V_g = motor displacement [cm³/r]

n = fan speed [rpm]

η_{vol} = volumetric efficiency = 90% at motor oil operating pressure of 150 bar

Max. outlet side pressure: 120 bar

Max. drain pressure: 2 bar

Fluid viscosity range: 10-600 mm²/s (recommended 30-45 mm²/s)

Fluid temperature range: up to 90 °C

Mineral oil to DIN 51524/25 DIN 51511

Filtration : ISO/DIS 4406 Code 19/16- Filtration grade $\beta_{25} > 75$

– The noise levels are only a guide as acoustic properties vary and depend on the characteristics of the room, connections, viscosity and resonance.

– Thermo-bypass for hydraulic motor drive: see chapter 4.

– Options: see accessory catalogue

1.2. HYDRAULIC DETAILS

1.2.1 Cooling capacity

depending on oil flow and the temperature differential ΔT between the oil inlet and air inlet
 For calculations with low ΔT values (i.e. below 10 °C), please contact our technical support staff.

OK-ELH2-5

Tolerance: $\pm 5\%$

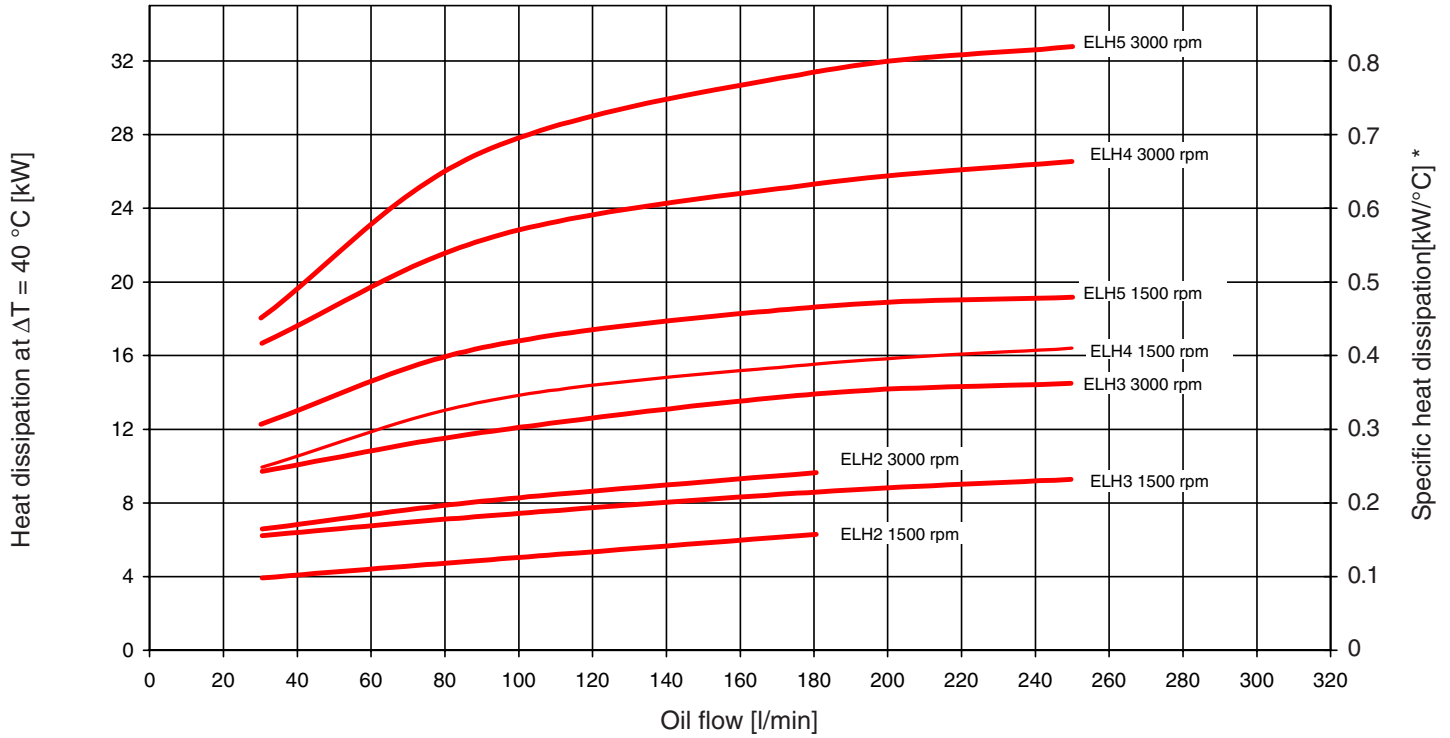

* : Values measured at $\Delta T = 40\text{ °C}$, may vary at lower ΔT values.

OK-ELH6-11

Tolerance: $\pm 10\%$

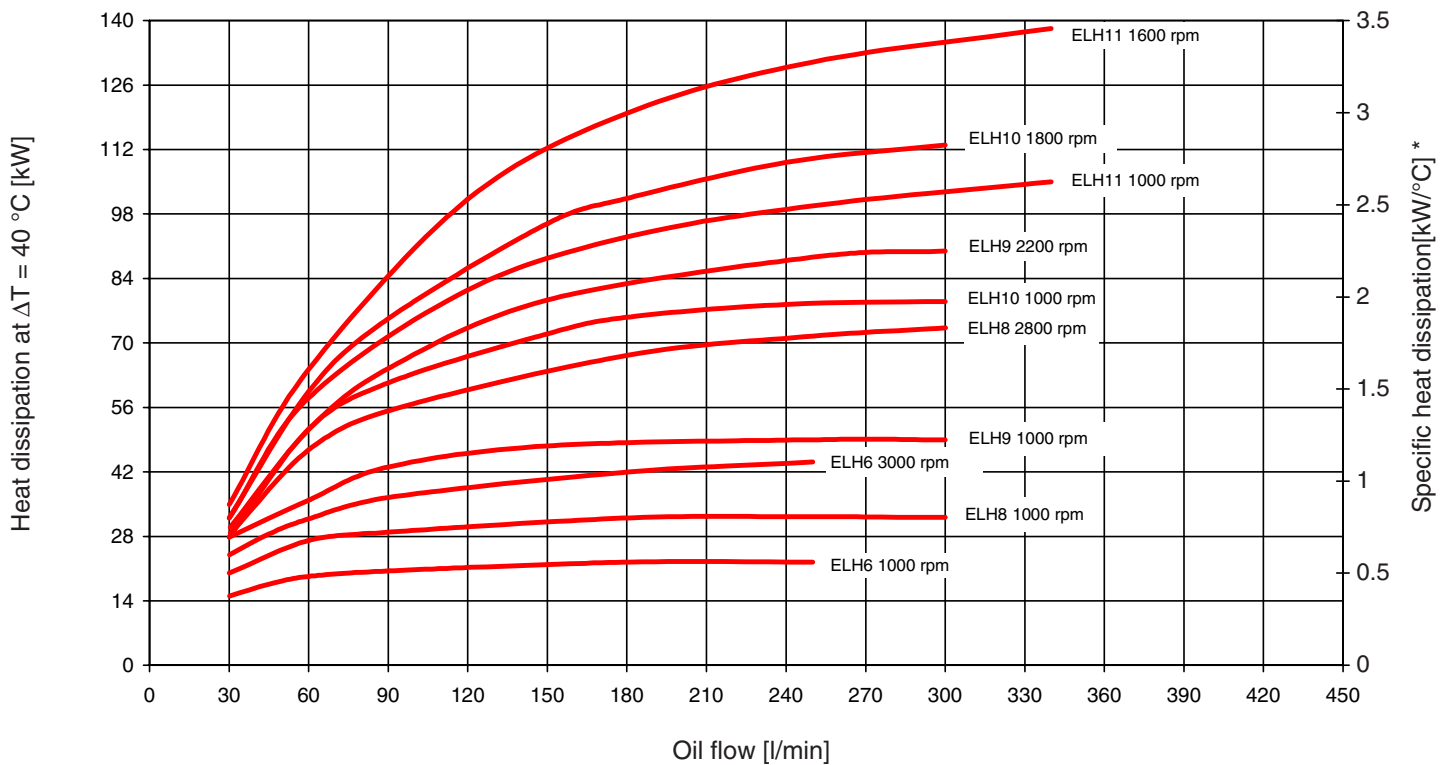

* : Values measured at $\Delta T = 40\text{ °C}$, may vary at lower ΔT values.

1.2.2 Pressure differential Δp measured at 30 mm²/s using mineral oil

OK-ELH2-5

Tolerance: $\pm 5\%$

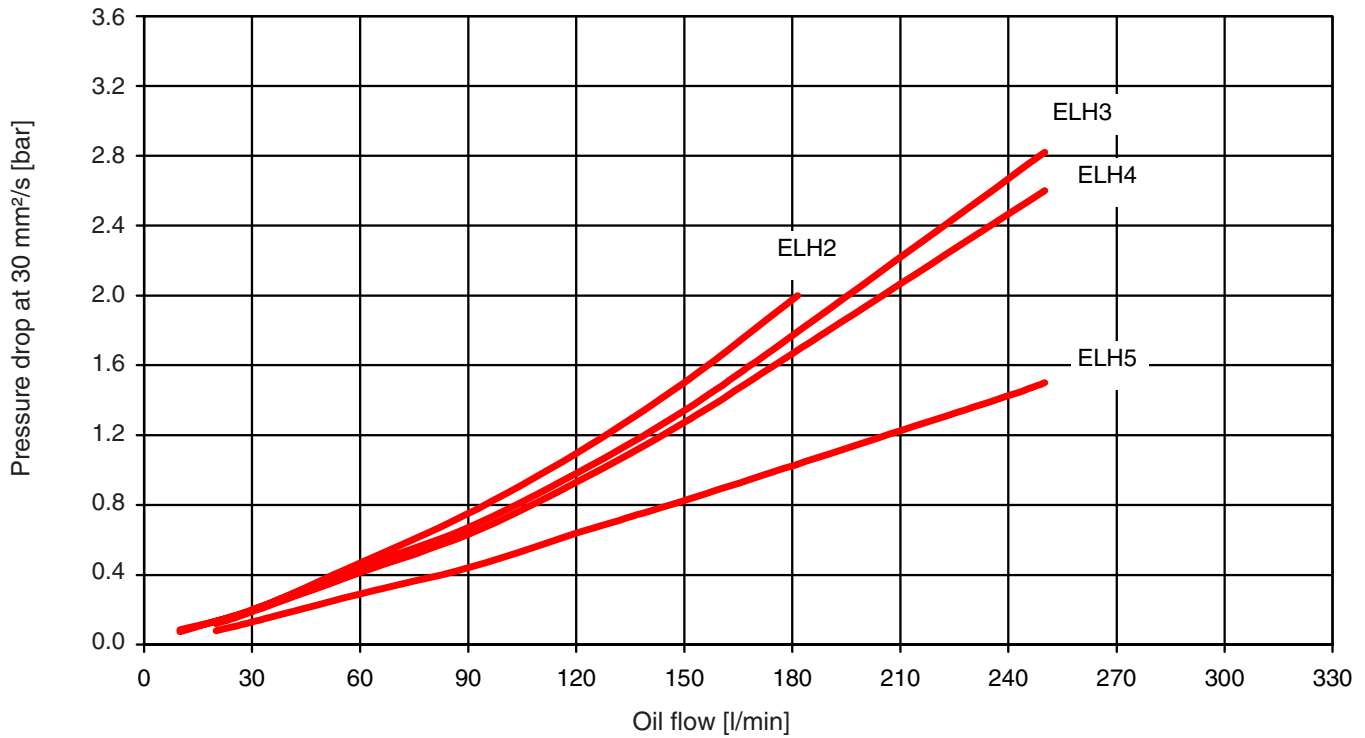

OK-ELH6-11

Tolerance: $\pm 10\%$

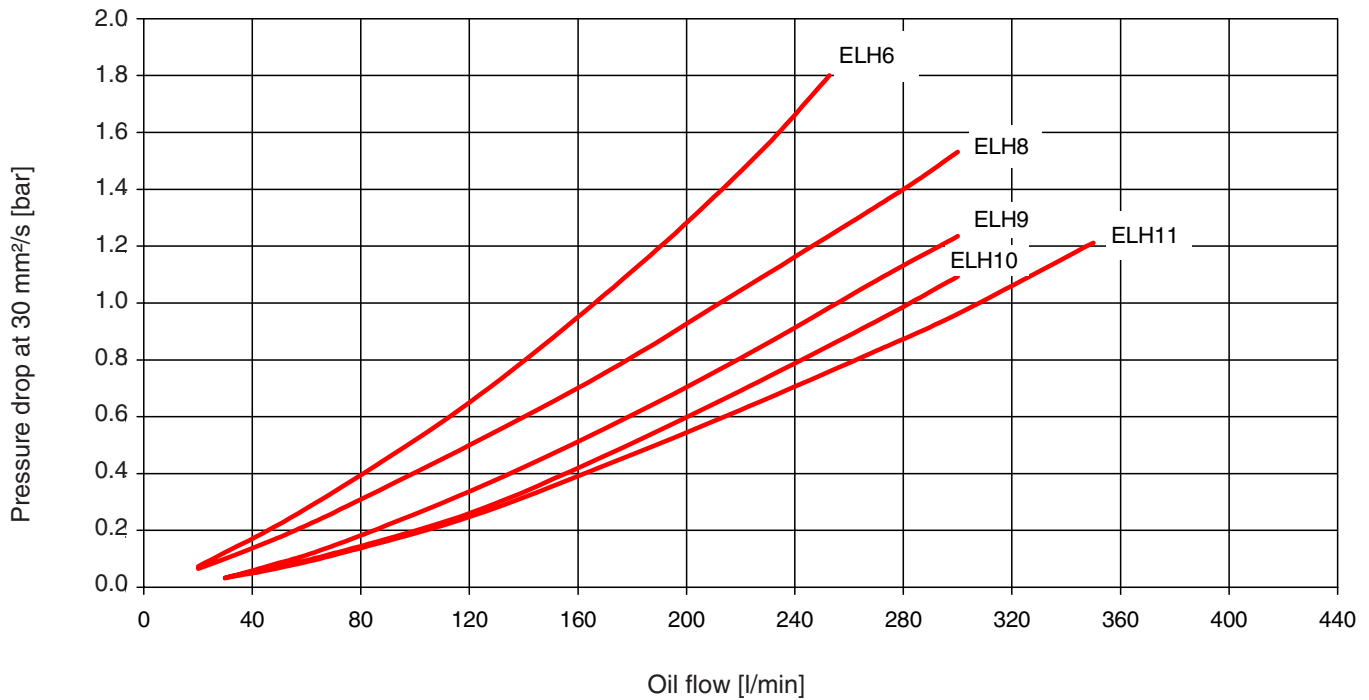

For other viscosities the result must be multiplied by K

Viscosity (mm ² /s)	10	15	22	32	46	68	100	150
Factor K	0.5	0.65	0.77	1	1.3	1.9	2.8	5.3

2. MODEL TYPE

(also order example)

OK-ELH2 / 1.0 / H6.3TB / 1 / S / AITF50

Type of cooler

OK ELH = Oil/air cooler

Size / motor speed

2-11 = See hydraulic details 1.2.

Type code and modification number

Hydraulic motor displacement

H6.3 = 6.3 cm³/r

H14 = 14 cm³/r

H22 = 22 cm³/r

H..TB = hydraulic motor with thermo-bypass (for more information see chapter 4)

Paint

1 = RAL 9005 (Standard)

Air flow direction

S = Suction (Standard)

Accessories (for more information see brochure accessories)

AITF50 = Thermostat (fixed)

LFM = Air filter on the air suction (Attention: with clean filter the cooling power decreases by ~8%)

LFG = Air filter grid on the air suction (Attention: with clean filter the cooling power decreases by ~5%)

GP = Vibration Absorber

FU = Feet for alternative mounting arrangement (only for ELH2-5; for the others the feet are already included)

IBP = Heat exchanger with integrated bypass

IBT = Heat exchanger with integrated thermo-bypass

3. DIMENSIONS

3.1. ELH2-4

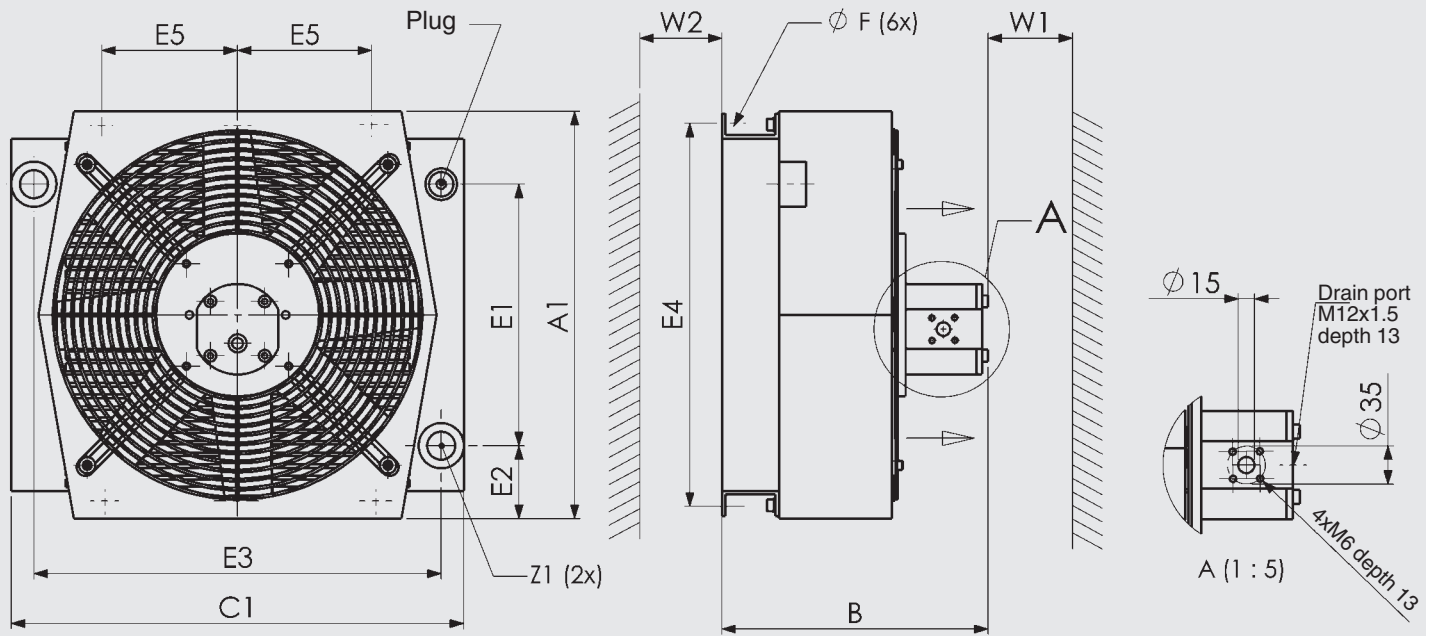

	A1	B ± 10	B ± 10	B ± 10	C1	E1	E2	E3	E4	E5	F	W1	W2	Z1	Plug
	± 5	6.3 cc	14 cc	22 cc	± 5	± 5	± 5	± 5	± 2	± 2		min	min		
ELH2	313	270	283	297	384	199	57	324	288	80	14X10	200	150	G1"	M22X1.5
ELH3	356	279	292	306	420	230	63	370	329	100	14X10	250	180	G1"	M22X1.5
ELH4	450	294	306	321	500	289	80	450	421	150	13X10	350	200	G1"	M22X1.5

3.2. ELH5

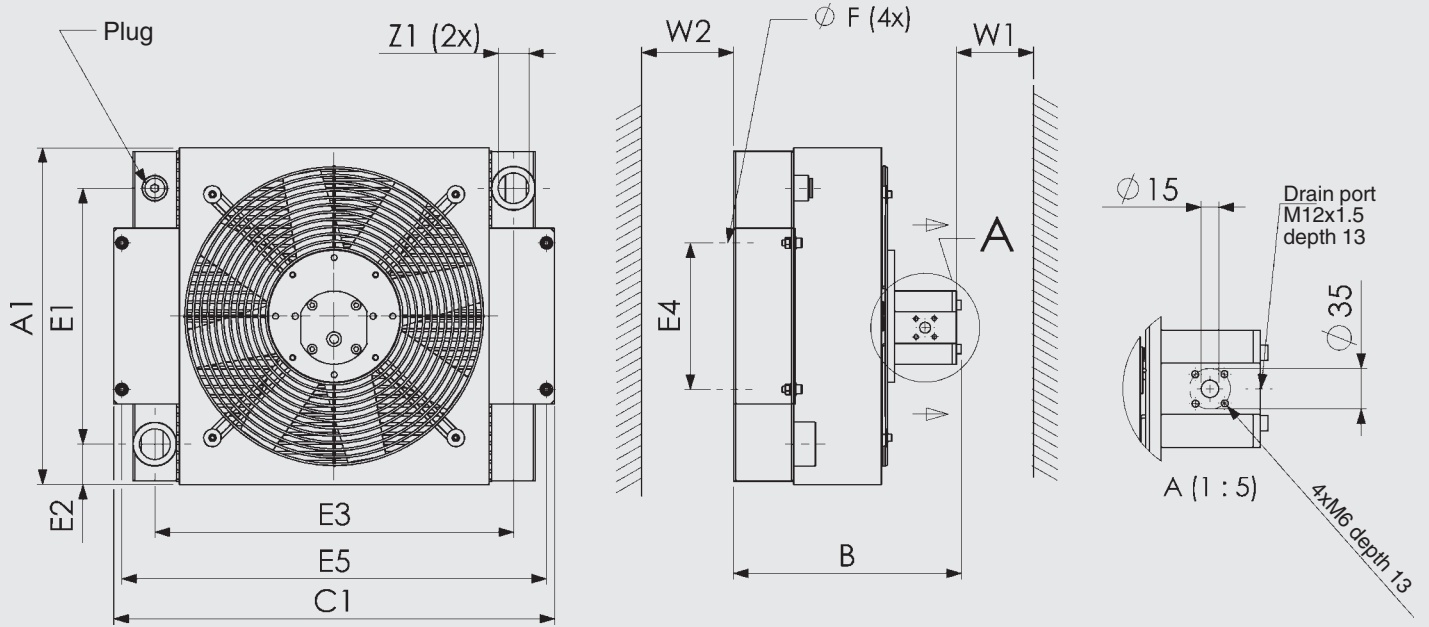

	A1	B ±10	B ±10	B ±10	C1	E1	E2	E3	E4	E5	F	W1	W2	Z1	Plug
	±5	6.3 cc	14 cc	22 cc	±5	±5	±5	±5	±2	±2		min	min		
ELH5	460	311	323	338	602	350	55	490	200	580	φ12	400	250	G1 1/4"	M22X1.5

3.3. ELH6-8

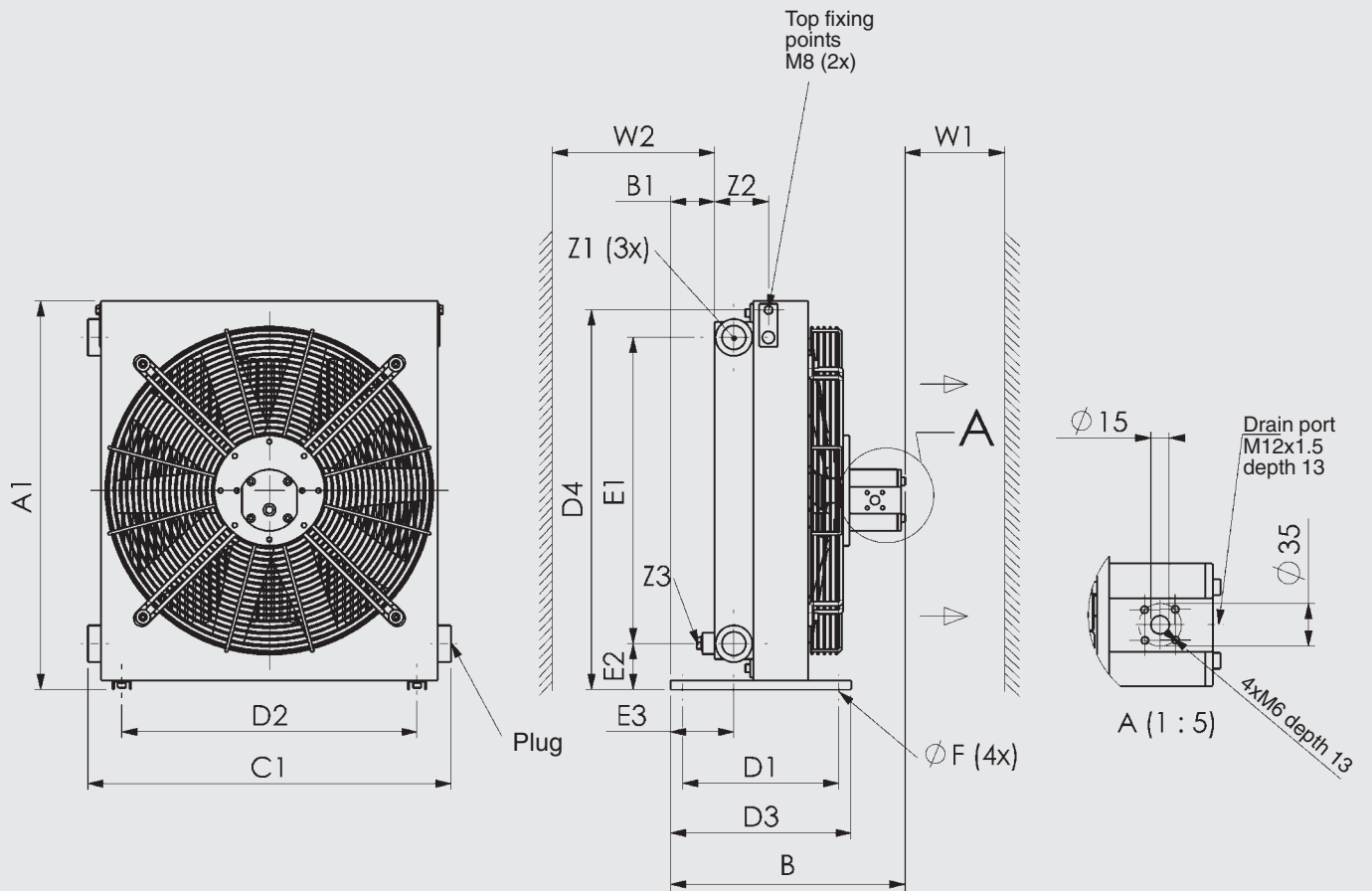

	A1	B±10	B±10	B±10	B1	C1	D1	D2	D3	D4	E1	E2	E3	ØF	W1	W2	Z1	Z2	Z3
	±10	6.33cc	14cc	22cc	±5	±10	±2	±2	±2	±2	±5	±5	±5		min*	min*			
OK-ELH6	635	383	395	410	72	593	255	482	295	620	500	75	103	9	1000	600	G1 ¼"	88	M22x1.5
OK-ELH8	762	383	395	410	53	695	255	482	295	749	628	75	94	9	1100	700	G1 ¼"	97	G3/4"

3.4. ELH9-11

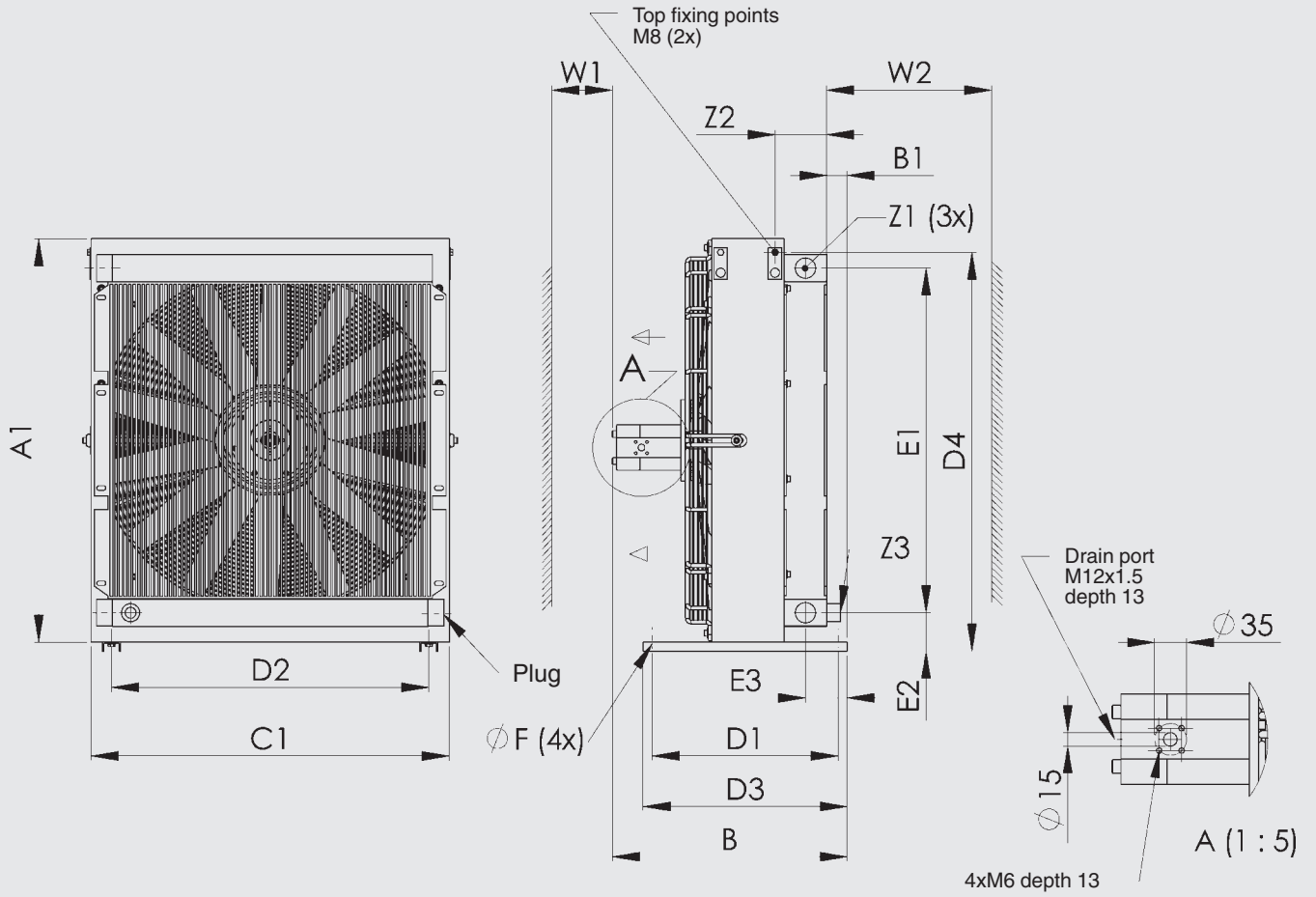

	A1	B±10	B±10	B1	C1	D1	D2	D3	D4	E1	E2	E3	ØF	W1	W2	Z1	Z2	Z3
	±10	14cc	22cc	±5	±10	±2	±2	±2	±2	±5	±5	±5		min*	min*			
OK-ELH9	910	504	519	45	790	410	700	450	880	760	85	92	9	1200	900	G1 ½"	114	G3/4"
OK-ELH10	1060	526	541	46	971	460	700	500	1030	910	90	93	9	1400	900	G1 ½"	114	G3/4"
OK-ELH11	1180	545	560	47	1050	460	700	500	1150	1060	75	93	9	1600	1000	G1 ½"	119	G3/4"

4. TEMPERATURE SENSING VARIABLE SPEED HYDRAULIC MOTOR

4.1. DESCRIPTION

The thermo valve is a pre-controlled pressure valve with temperature-dependent pressure control and is mounted on the hydraulic motor in place of the existing cover plate.

The pressure setting of the valve automatically changes dependent on the temperature and thus controls the motor speed. In addition to the actual temperature-controlled pressure setting, a mechanical maximum pressure control and a recharging valve are fitted as a non-return valve.

The switching temperature values can be set from 40 to 70 °C and the pressure can be controlled up to 100 °C: please contact our sales for the dimensioning of the thermo-bypass.

All the standard hydraulic motors can be used with the thermo-bypass. The minimum oil pressure at which the thermo control starts to work is 8 bar, i.e. a maximum residual power consumption corresponding to 8 bars is to be foreseen also in by-pass phase.

4.2. DIMENSIONS

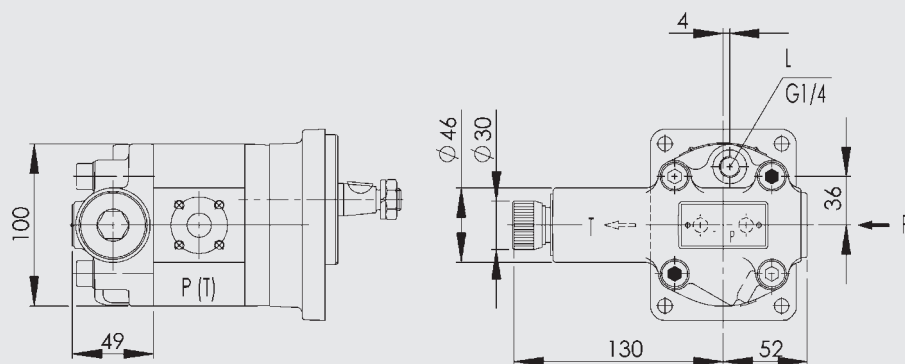

4.3. SCHEME

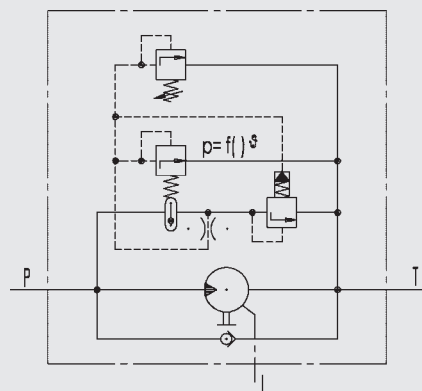

5. CERTIFICATION FOLLOWING EN 1048

Hydac SA design and manufacture high quality coolers that are tested and certified to give reliable and repeatable high performance. To ensure the performance is accurate, testing in compliance with a recognised international test standard is the best solution. For air/liquid coolers this is EN1048.

Hydac SA test procedure complies with the requirements of EN1048 and both the procedure and test equipment are independently inspected and certified by TÜV SÜDDEUTSCHLAND.

The cooler performance details in this brochure have been tested following EN1048.



6. NOTE

The information in this brochure relates to the operating conditions and applications described. For applications or operating conditions not described, please contact the relevant technical department. Subject to technical modifications.