

## Solenoid Directional Valve SAE 10-Cartridge – 350 bar 2/2 Normally Open

WS10Y-01  
Poppet Type - Pilot Operated

### FUNCTION

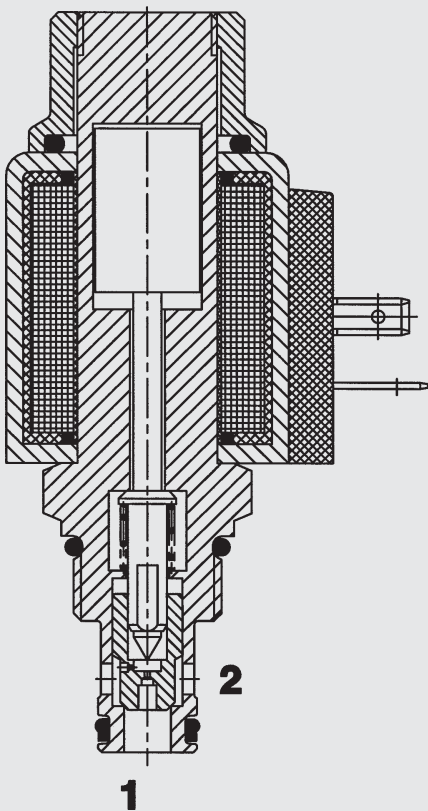

In the de-energized mode, the valve allows flow from 2 to 1. Flow from 1 to 2 is severely restricted in this mode. When energized, the valve blocks flow from 2 to 1. In this mode the valve will allow flow from 1 to 2 after the hydraulic force overcomes the solenoid force of 2.5 to 10 bar.

### FEATURES

- Wet armature solenoid
- Wide voltage tolerance
- All valve parts made of high-strength steel with hardened and ground components to assure minimal wear and extended service life
- All surfaces zinc-plated and corrosion-proof
- Waterproof design standard
- Wide variety of coils and connectors available
- One piece body design

### SPECIFICATIONS

Operating Pressure:	350 bar
Proof Pressure:	520 bar
Nominal Flow:	75 l/min
Internal Leakage:	leakfree (less than 5 drops/min) max. at 350 bar
Media Operating Temp. Range:	-20 °C to +120 °C
Ambient Temp. Range:	-20 °C to + 60 °C
Coil Duty Rating:	Continuous from 85% to 115% of nominal voltage
Current Draw at 20 °C:	1.5 amps at 12 V DC 0.8 amps at 24 V DC
Minimum Pull-in Voltage:	85 % of nominal
Response Time:	Energized: 55 ms De-energized: 35 ms typical 24 V DC-coil
Fluids:	Mineral-based or synthetics with lubricating properties
Viscosity:	7.4 to 420 cSt
Filtration:	Class 21/19/16 according to ISO 4406 or cleaner
Installation:	No orientation restrictions
Material:	Valve body: carbon steel Piston: carbon steel Sealings: NBR (Standard) FKM (Option)
	Coil: Steel/Polyamide
Cavity:	FC10-2
Weights:	Valve complete: 370 g Coil only: 190 g

