

17 l/min  
350 bar

## FUNCTION

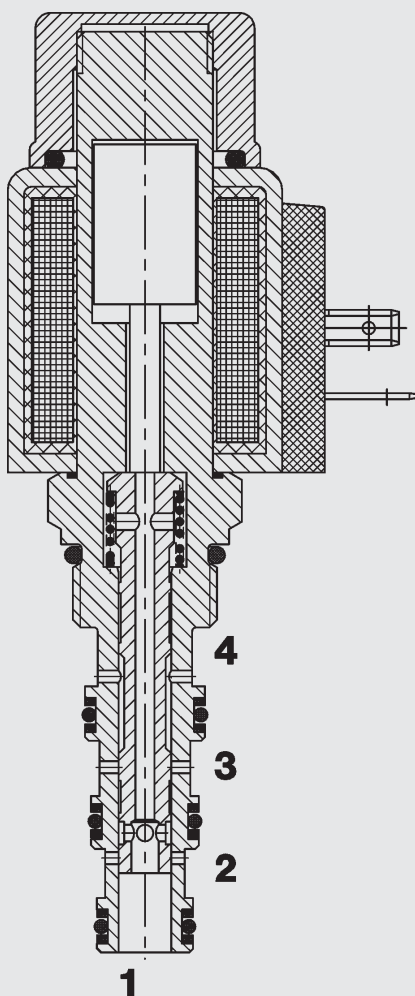

In the de-energized mode, the valve blocks flow in all directions. When energized, the valve allows bidirectional flow between ports 3 and 4 and between ports 1 and 2.

## 4/2-Solenoid Directional Valve SAE 8-Cartridge - 350 bar

WK08Z-01  
SPOOL Type - Direct Operated

### FEATURES

- All surfaces zinc-plated and corrosion-proof
- All valve parts made of high-strength steel with hardened and ground components to ensure minimal wear and extended service life
- Coil seals protect the solenoid system
- Wide variety of connectors available
- Rigid design using one-piece body minimizes the effect of eccentricities in cavity and maximizes reliability
- Excellent switching performance by high power HYDAC solenoid
- Low pressure drop due to CFD optimized flow-path

### SPECIFICATIONS

Operating pressure:	350 bar
Proof pressure:	520 bar
Nominal flow:	17 l/min Consult factory for flow ratings above 207 bar
Internal leakage:	90 cm <sup>3</sup> /min max at 250 bar and 34 mm <sup>2</sup> /s
Media operating temp. range:	-20 °C to +120 °C
Ambient temp. range:	-20 °C to +60 °C
Fluids:	Hydraulic oil to DIN 51524 Part 1 and 2
Viscosity:	7.4 to 420 mm <sup>2</sup> /s
Filtration:	Class 21/19/16 according to ISO 4406 or cleaner
Material:	Valve body: high tensile steel Spool: hardened and ground steel Seals: NBR (standard) FKM (optional) Coil: Steel/Polyamide
Cavity:	FC08-4
Weights:	Valve complete: 0.38 kg Coil only: 0.19 kg
Type of voltage	DC solenoid, AC voltage is rectified by a built-in rectifier built into the coil
Current draw at 20 °C:	1.5 A at 12 V DC 0.8 A at 24 V DC
Voltage tolerance	± 15 % of nominal voltage
Switch-on time	Continuous up to 115 % of nominal voltage at 60 °C ambient temperature

