

Solenoid Directional Valve SAE 8-Cartridge - 250 bar

2/2-Normally Closed
WS08W-01

Poppet Type - Direct Operated

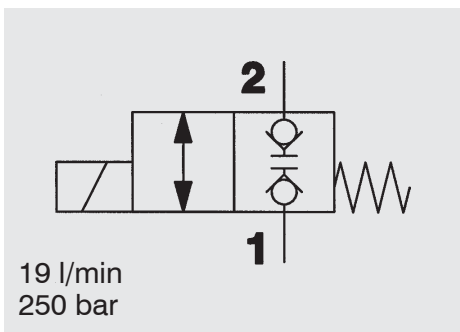

FUNCTION

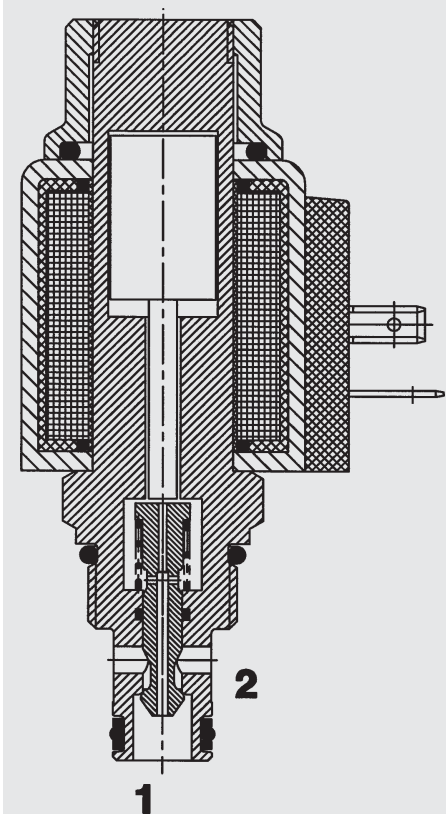

In the de-energized mode, the valve blocks flow in both directions.

When energized, the valve allows flow in both directions.

FEATURES

- Wet armature solenoid
- Wide voltage tolerance
- All valve parts made of high-strength steel with hardened and ground components to assure minimal wear and extended service life
- All surfaces zinc-plated and corrosion-proof
- Waterproof design standard
- Wide variety of coils and connectors available
- One piece body design

SPECIFICATIONS

Operating Pressure:	250 bar
Proof Pressure:	520 bar
Nominal Flow:	19 l/min
Internal Leakage:	leakfree (less than 5 drops/min) max. at 250 bar
Media Operating Temp. Range:	-20 °C to +120 °C
Ambient Temp. Range:	-20 °C to +60 °C
Coil Duty Rating:	Continuous from 85 % to 110 % of nominal voltage
Current Draw at 20 °C:	1.5 amps at 12 V DC 0.8 amps at 24 V DC
Minimum Pull-in Voltage:	85 % of nominal
Response Time:	Energized: 35 ms De-energized: 50 ms typical 24 V DC-coil
Fluids:	Mineral-based or synthetics with lubricating properties
Viscosity:	7.4 to 420 cSt
Filtration:	Class 21/19/16 according to ISO 4406 or cleaner
Installation:	No orientation restrictions
Material:	Valve body: carbon steel Piston: carbon steel Seals: NBR (Standard) FKM (Option) Steel/Polyamide
Cavity:	FC08-2
Weights:	Valve complete: 330 g Coil only: 190 g

DIMENSIONS

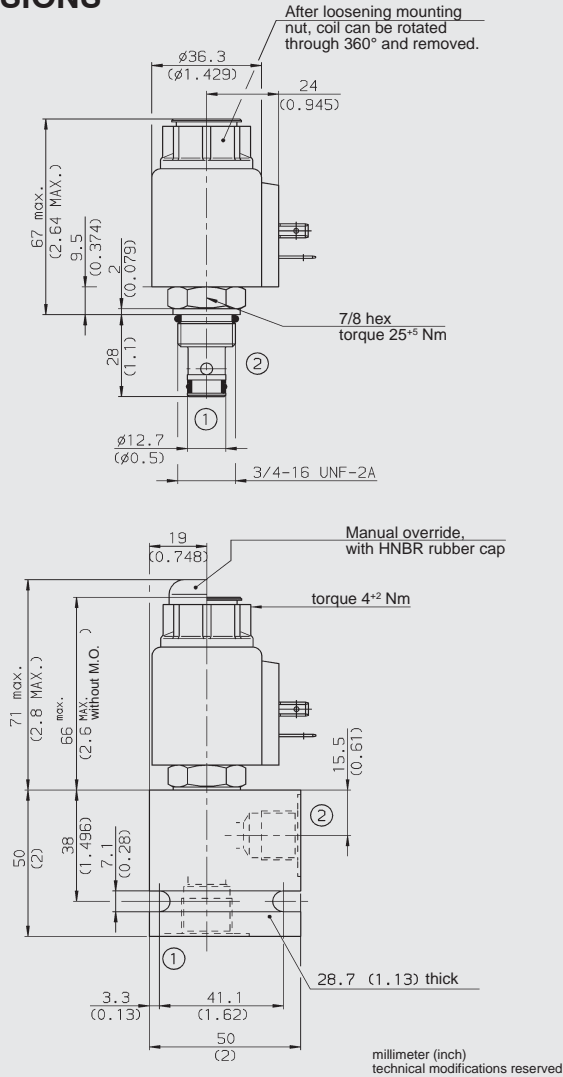

MODEL CODE

WS08W-01 M - C - N - 24 DG

Basic Model

Option

Omission = No Option
M = Manual Override

Body and Ports*

C = Cartridge Only
SB3 = 3/8 BSP ports, steel body
SS6 = SAE-6 ports, steel body
AB3 = 3/8 BSP ports, aluminium body
AS6 = SAE-6 ports, aluminium body

Seals

N = NBR
V = FKM

Coil Voltage

DC

10 = 10 V DC
12 = 12 V DC
24 = 24 V DC
36 = 36 V DC
48 = 48 V DC
110 = 110 V DC available with termination DG only

AC (internally full wave rectified)

24 = 24 V AC
115 = 115 V AC
230 = 230 V AC

Coil Connector

DC: DG = DIN Connector (DIN 43650)
DS = Dual Spade SAEJ858a
DL = Leadwires (2) - 457mm (18") long
DW = Weather Pack Connector on leadwires - 241 mm (9.5") long
DK = Kostal connector
DT = 2-pole AMP Junior Timer plug
AC: AG = DIN Connector (DIN 43650)

Standard models

Model code	Stock no.
WS08W-01-C-N-24DG	3011913
WS08W-01-C-N-230AG	3043358

* Standard Line Bodies

Code	Part No	Material	Ports	Pressure
FH082-SB3	560919	Steel, zinc-plated	3/8 BSP	420 bar
FH082-SS6	560917	Steel, zinc-plated	SAE-6	420 bar
FH082-AB3	3011423	Aluminium, clear anodized	3/8 BSP	245 bar
FH082-AS6	3011409	Aluminium, clear anodized	SAE-6	245 bar

PERFORMANCE (Cartridge Only)

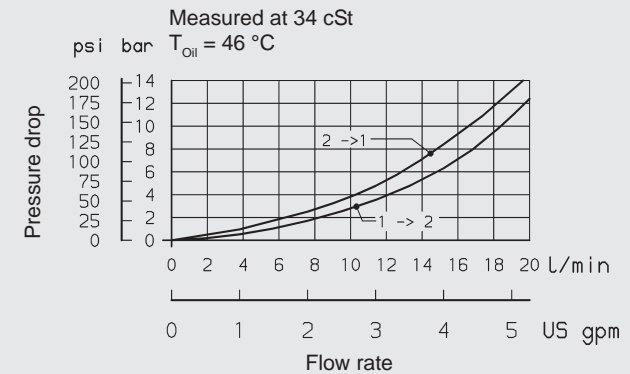

NOTE

The information in this brochure relates to the operating conditions and applications described. For applications or operating conditions not described, please contact the relevant technical department. Subject to technical modifications.

HYDAC Fluidtechnik GmbH
Justus-von-Liebig-Str.
D-66280 Sulzbach/Saar
Tel: 0 68 97 /509-01
Telefax: 0 68 97 /509-598
E-Mail: flutec@hydac.com

CAVITY

FC08-2

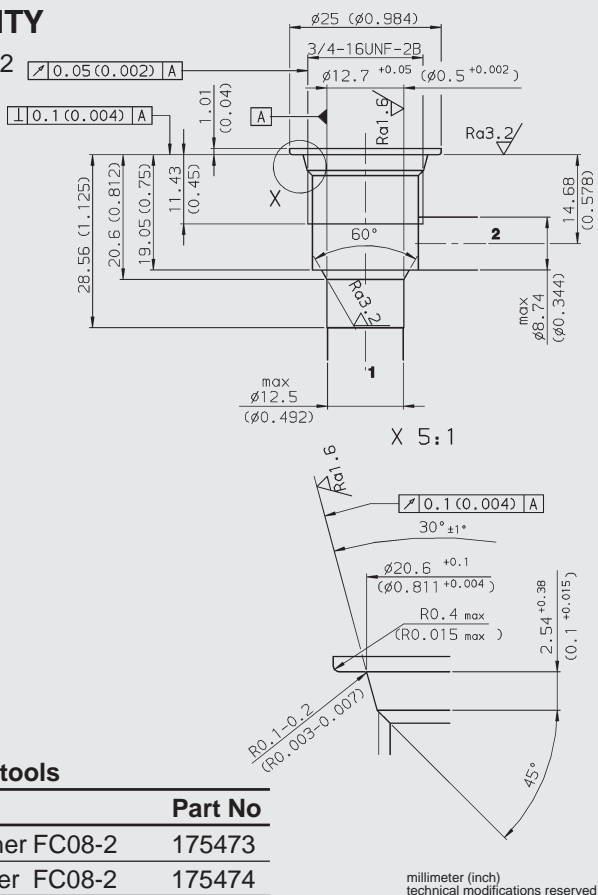

Form tools

Tool	Part No
Rougher FC08-2	175473
Finisher FC08-2	175474

millimeter (inch)
technical modifications reserved