

FUNCTION

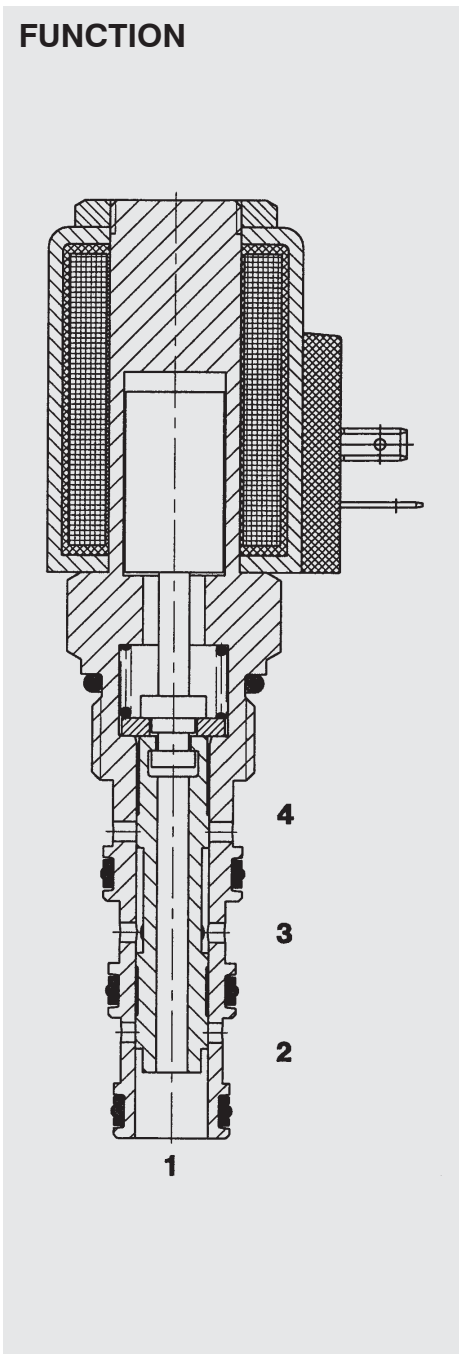

In the de-energized mode, the valve blocks flow in all directions.

When energized, the valve allows flow from 3 to 4 or 4 to 3 and from 2 to 1 or 1 to 2.

4/2-Solenoid Directional Valve SAE 10-Cartridge - 350 bar

WK10Z-01

SPOOL Type - Direct Operated

FEATURES

- Wet armature solenoid
- Wide voltage tolerance
- All surfaces zinc-plated and corrosion-proof
- Waterproof design as standard
- Wide variety of coils and connectors available
- One piece body design

SPECIFICATIONS

Operating Pressure:	350 bar
Proof Pressure:	520 bar
Nominal Flow:	32 l/min
Internal Leakage:	100 cm ³ /min max at 250 bar and 34 cSt
Media Operating Temp. Range:	-20 °C to +120 °C
Ambient Temp. Range:	-20 °C to +60 °C
Coil Duty Rating:	Continuous from 85% to 115% of nominal voltage
Current Draw at 20 °C (68 °F):	2.22 amps at 12 V DC 1.13 amps at 24 V DC
Minimum Pull-in Voltage:	85 % of nominal
Fluids:	Mineral-based or synthetics with lubricating properties
Viscosity:	7.4 to 420 cSt
Filtration:	Class 21/19/16 according to ISO 4406 or cleaner
Material:	Valve body: carbon steel Spool: carbon steel Seals: Nitrile (standard) FKM (optional) Steel/Polyamide
Cavity:	FC10-4
Weights:	Valve complete: 480 g Coil only: 230 g

