

FUNCTION

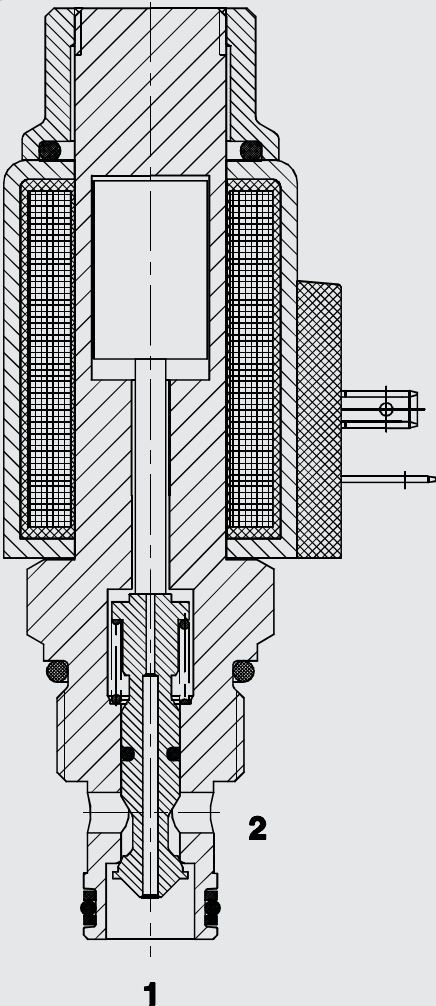

In the de-energized mode, the valve blocks flow in both directions.

When energized, the valve allows flow in both directions.

2/2-Solenoid Directional Valve SAE 10-Cartridge - 350 bar

2/2 Normally Closed

WS10W-01

Poppet Type - Direct Operated

FEATURES

- Wet armature solenoid
- Wide voltage tolerance
- All surfaces zinc-plated and corrosion-proof
- Waterproof design standard
- Wide variety of coils and connectors available
- One piece body design

SPECIFICATIONS

Operating Pressure:	350 bar
Proof Pressure:	520 bar
Nominal Flow:	40 l/min
Internal Leakage:	leakagefree (less than 5 drops/min) max. at 350 bar.
Media Operating Temp. Range:	-20 °C to +120 °C
Ambient Temp. Range:	-20 °C to +60 °C
Coil Duty Rating:	Continuous from 85% to 115% of nominal voltage
Current Draw at 20 °C:	2.22 amps at 12 V DC 1.13 amps at 24 V DC
Minimum Pull-in Voltage:	85 % of nominal
Fluids:	Mineral-based or synthetics with lubricating properties
Viscosity:	7.4 to 420 cSt
Filtration:	Class 21/19/16 according to ISO 4406 or cleaner
Material:	Valve body: carbon steel Spool: carbon steel Seals: NBR (standard) FKM (optional) Steel/Polyamide
Cavity:	FC10-2
Weights:	Valve complete: 460 g Coil only: 230 g

DIMENSIONS

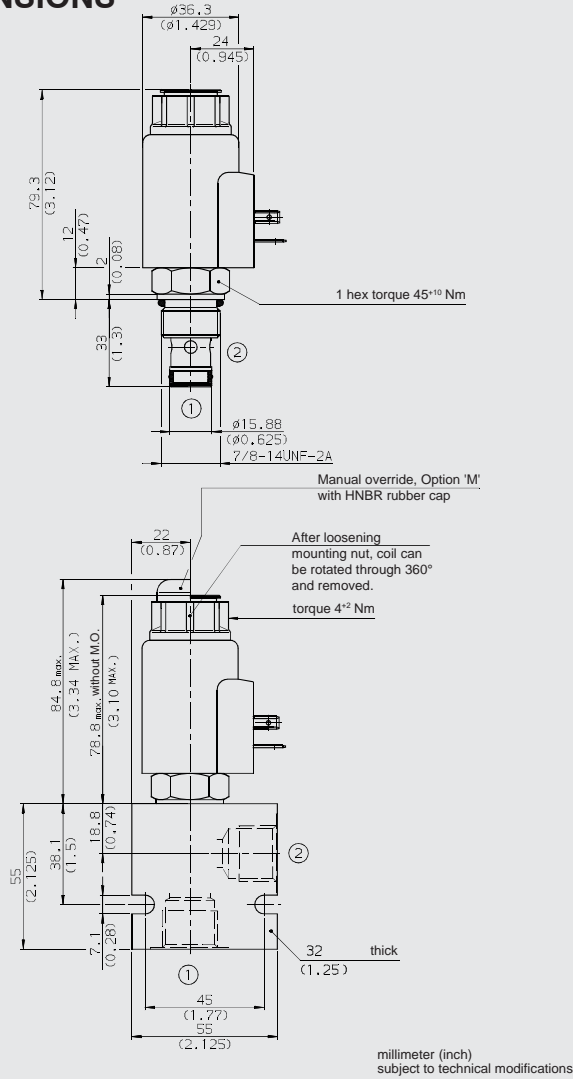

MODEL CODE

WS10W-01 M - C - N - 24 DG

Basic Model

Option
Omission = No Option
M = Manual Override

Body and Ports*

C = Cartridge only
SB4 = 1/2 BSP ports, steel body
SS8 = SAE-8 ports, steel body
AB4 = 1/2 BSP ports, aluminium body
AS8 = SAE-8 ports, aluminium body

Seals

N = NBR
V = FKM

Coil Voltage

DC

10 = 10 V DC
12 = 12 V DC
24 = 24 V DC
36 = 36 V DC
48 = 48 V DC
110 = 110 V DC available with termination DG only

AC (internally full wave rectified)

24 = 24 V AC
115 = 115 V AC
230 = 230 V AC

Coil Connector

DC: DG = DIN Connector (DIN 43650)
DS = Dual Spade SAEJ858a
DL = Leadwires (2) - 457mm (18") long
DW = Weather Pack Connector on leadwires - 241 mm (9.5") long
DK = Kostal connector
DT = 2-pole AMP Junior Timer plug

AC: AG = DIN Connector (DIN 43650)

Standard models

Model code	Stock no.
WS10W-01-C-N-24DG	3105385
WS10W-01-C-N-230AG	3105386

* Standard Line Bodies

Code	Stock no.	Material	Ports	Pressure
FH102-SB4	3037594	Steel, zinc-plated	1/2 BSP	420 bar
FH102-SS8	3037612	Steel, zinc-plated	SAE-8	420 bar
FH102-AB4	3037777	Aluminium, clear anodized	1/2 BSP	245 bar
FH102-AS8	3037778	Aluminium, clear anodized	SAE-8	245 bar

CAVITY

FC10-2

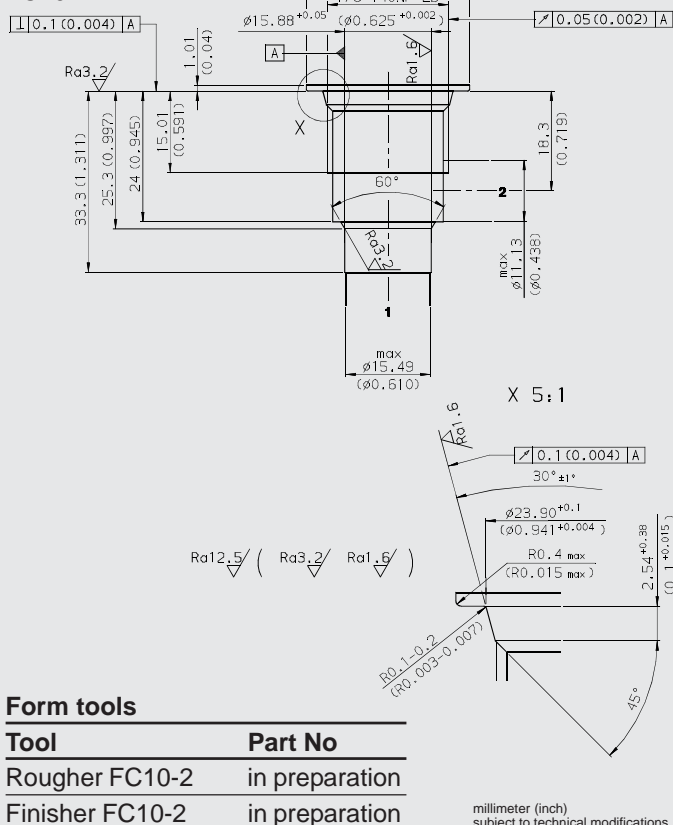

Form tools

Tool	Part No
Rougher FC10-2	in preparation
Finisher FC10-2	in preparation

millimeter (inch)
subject to technical modifications

PERFORMANCE

Measured at 34 cSt

T_{oil} = 46°C

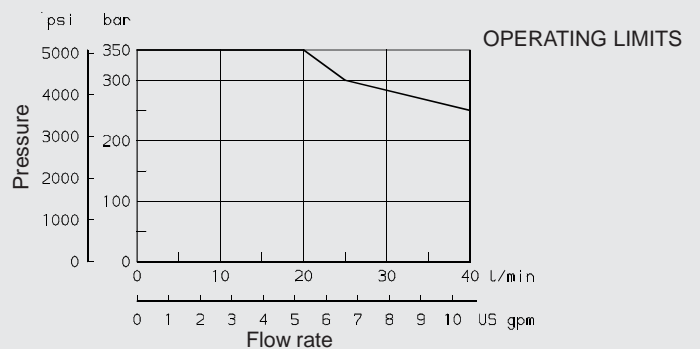
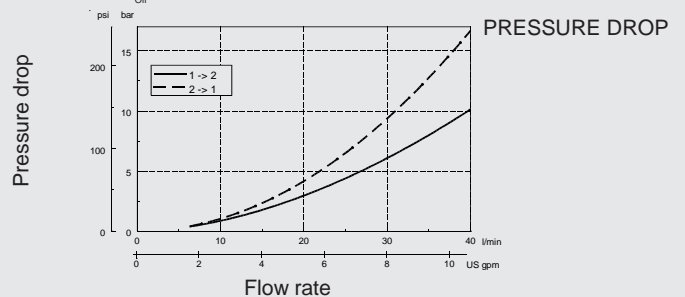

NOTE

The information in this brochure relates to the operating conditions and applications described. For applications or operating conditions not described, please contact the relevant technical department. Subject to technical modifications.

HYDAC Fluidtechnik GmbH

Justus-von-Liebig-Str.
D-66280 Sulzbach/Saar
Tel: 0 68 97 /509-01
Telefax: 0 68 97 /509-598
E-Mail: flutec@hydac.com