

160 l/min
350 bar

FUNCTION

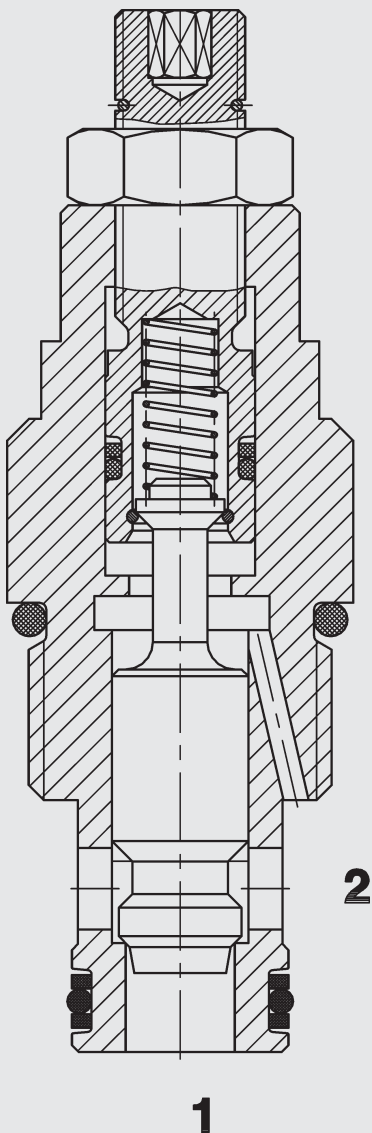

The SDR10A controls flow from port 2 to port 1 and is non pressure compensated. That means the flow rate depends on the pressure differential and viscosity. There is free flow from port 1 to port 2.

Needle Valve – Free Reverse Flow SAE 10-Cartridge – 350 bar

SDR10A-01

FEATURES

- All surfaces zinc-plated and corrosion proof
- All valve parts made of high-strength steel with hardened and ground components to ensure minimal wear and extend service life
- Good stability throughout flow range
- Low leakage
- Compact design

SPECIFICATIONS

Operating pressure:	350 bar
Nominal flow:	160 l/min
Standard cracking pressure:	1 bar
Media operating temp. range:	-20 °C to +120 °C
Fluids:	Mineral-based or synthetics with lubricating properties
Viscosity:	7.4 to 420 cSt
Filtration:	Class 21/19/16 according to ISO 4406 or cleaner
Material:	Valve body: carbon steel Spool: carbon steel Seals: NBR (standard) FKM (optional)
Cavity:	FC10-2
Weight:	149 g

DIMENSIONS

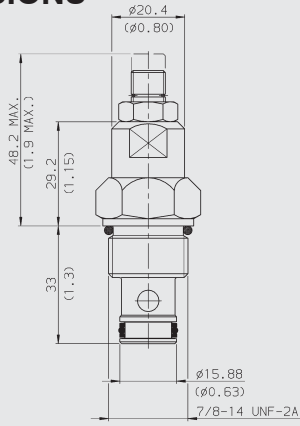

1" hex torque 40- 50 Nm
(29.5- 37 ft-lbs)

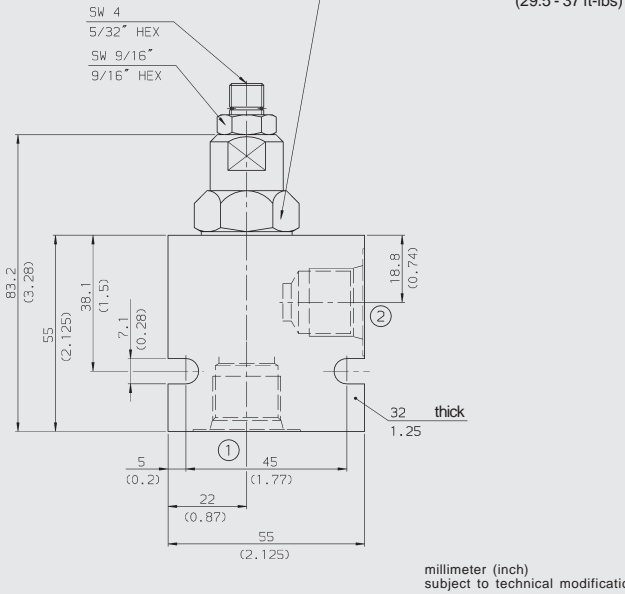

CAVITY

FC10 -2

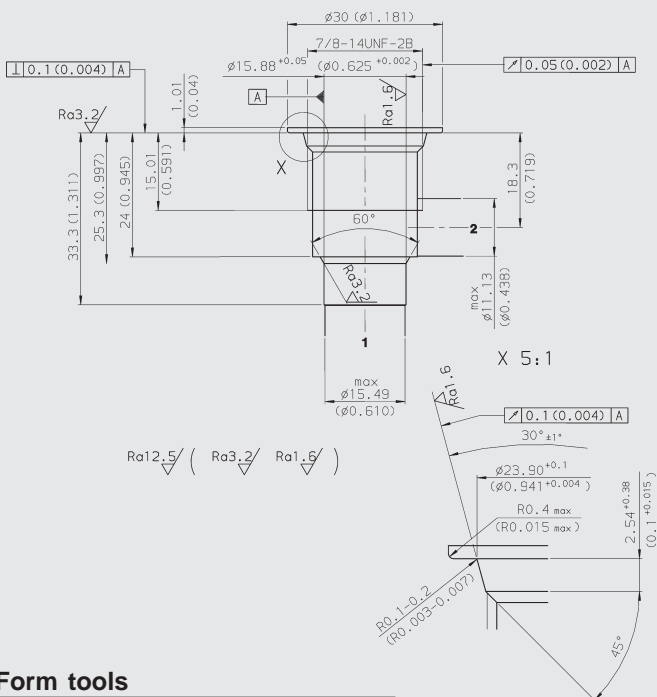

Form tools

Tool	Part No
Rougher FC10-2	in preparation
Finisher FC10-2	in preparation

millimeter (inch)
subject to technical modifications

MODEL CODE

SDR10A-01 - C - N - 15 V

Basic Model

Body and Ports*

C = Cartridge only

SB4 = 1/2 BSP ports, steel body

SS8 = SAE-8 ports, steel body

AB4 = 1/2 BSP ports, aluminium body

AS8 = SAE-8 ports, aluminium body

Seals

N = NBR

V = FKM

Bias spring

15 = 1.0 bar

Adjustment Option

V = Allen head (HEX 5/32")

H = Knob adjustment

*Standard Line Bodies

Code	Part No	Material	Ports	Pressure
FH102-SB4	3037594	Steel, zinc-plated	1/2 BSP	420 bar
FH102-SS8	3037612	Steel, zinc-plated	SAE-8	420 bar
FH102-AB4	3037777	Aluminium, clear anodized	1/2 BSP	245 bar
FH102-AS8	3037778	Aluminium, clear anodized	SAE-8	245 bar

PERFORMANCE

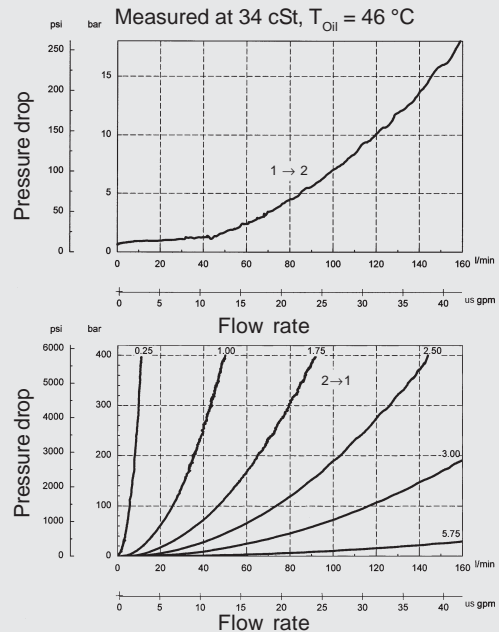

NOTE

The information in this brochure relates to the operating conditions and applications described. For applications or operating conditions not described, please contact the relevant technical department. Subject to technical modifications.

HYDAC Fluidtechnik GmbH
Justus-von-Liebig-Str.
D-66280 Sulzbach/Saar
Tel: 0 68 97 /509-01
Telefax: 0 68 97 /509-598
E-Mail: flutec@hydac.com