



Nordhydraulic
HYDAC INTERNATIONAL

Directional control valve RS 220



Solutions that power your visions

31-02-RS220-03

Nordhydraulic AB

P.O Box 189 (Industrivägen 15)
SE-872 24 KRAMFORS
Sweden

Telephone: Int. +46 612 71 72 00
Telefax: Int. +46 612 71 72 15

E-mail: info@nordhydraulic.se
Web: www.nordhydraulic.se

Data sheet

Directional control valve / RS 220

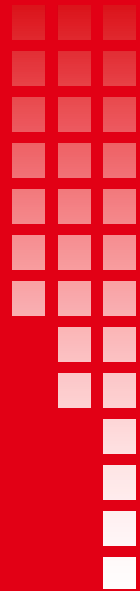

RS 220

Make use of the Nordhydraulic expertise

Our skilled and experienced design and application engineers are at your disposal, helping you to specify the valve configuration that meets your application requirements.

With the electric remote controlled valve RS 220 for open centre systems we can offer you a valve concept to match your high demands of controllability and performance.

Key valve features

RS 220 is a sectional valve designed for system pressures up to 350 bar and pump flows up to 90 l/min.

It is available with 1 to 10 working sections per valve assembly.

RS 220 is designed with an open centre for fixed and variable displacement pumps.

It is available with electro-hydraulic or hydraulic proportional remote control, but the valve can also be manually operated.

The electro-hydraulic proportional version in particular offers compact design with internal pilot oil supply, solenoids integrated in the valve body and integral hand levers for manual override/manual operation.

RS 220 can be fully adapted for marine applications.

The valve offers excellent operating characteristics because of the specially designed spools for different applications.

Low and uniform spool forces are the result of careful balancing of the flow forces.

Q-function

The flow control (Q-function) of the inlet section bypasses the major part of the pump flow to tank when the system is idling, thereby greatly reducing heat generation. But it also gives access to the full pump flow when the services are operated and provide improved operating characteristics.

Applications

The RS 220 is ideal for applications where you need excellent control characteristics such as cranes, sky-lifts, excavators, telescopic load handlers, skid-loaders, wheel loaders etc.

Remote control

The RS 220 is designed with an integrated pilot supply system in order to achieve an easy installation and

a reliable remote control function. It is also possible (and in some cases to prefer) to supply the pilot system externally.

Further RS 220 properties and possibilities

- A wide choice of spools and spool controls for different flow combinations and for several applications and systems.
- A full range of service port valves.
- Possibility of high pressure carry-over.
- Electrical unloading.
- Manual versions easily convertible to remote control.



Data sheet

This data sheet presents a selection of standard components and how to specify these in a valve assembly according to your application requirements. For further information on RS 220 and available components, please contact Nordhydraulic.



Table of contents

<i>Technical data</i>	<i>page</i>	4
<i>Dimensions, weight</i>	<i>page</i>	5
<i>Electrical unloading valve</i>	<i>page</i>	5
<i>Inlet sections</i>	<i>page</i>	6 - 7
<i>Main relief function</i>	<i>page</i>	6
<i>Working sections</i>	<i>page</i>	8 - 9
<i>Solenoid valves, load check valve</i>	<i>page</i>	9
<i>Outlet sections</i>	<i>page</i>	10 - 11
<i>Pilot pressure valve</i>	<i>page</i>	11
<i>Pressure reducing valve</i>	<i>page</i>	11
<i>Spool controls</i>	<i>page</i>	12
<i>Lever mechanism</i>	<i>page</i>	13
<i>Spools</i>	<i>page</i>	13
<i>Service port valves</i>	<i>page</i>	14
<i>Hydraulic diagrams</i>	<i>page</i>	15

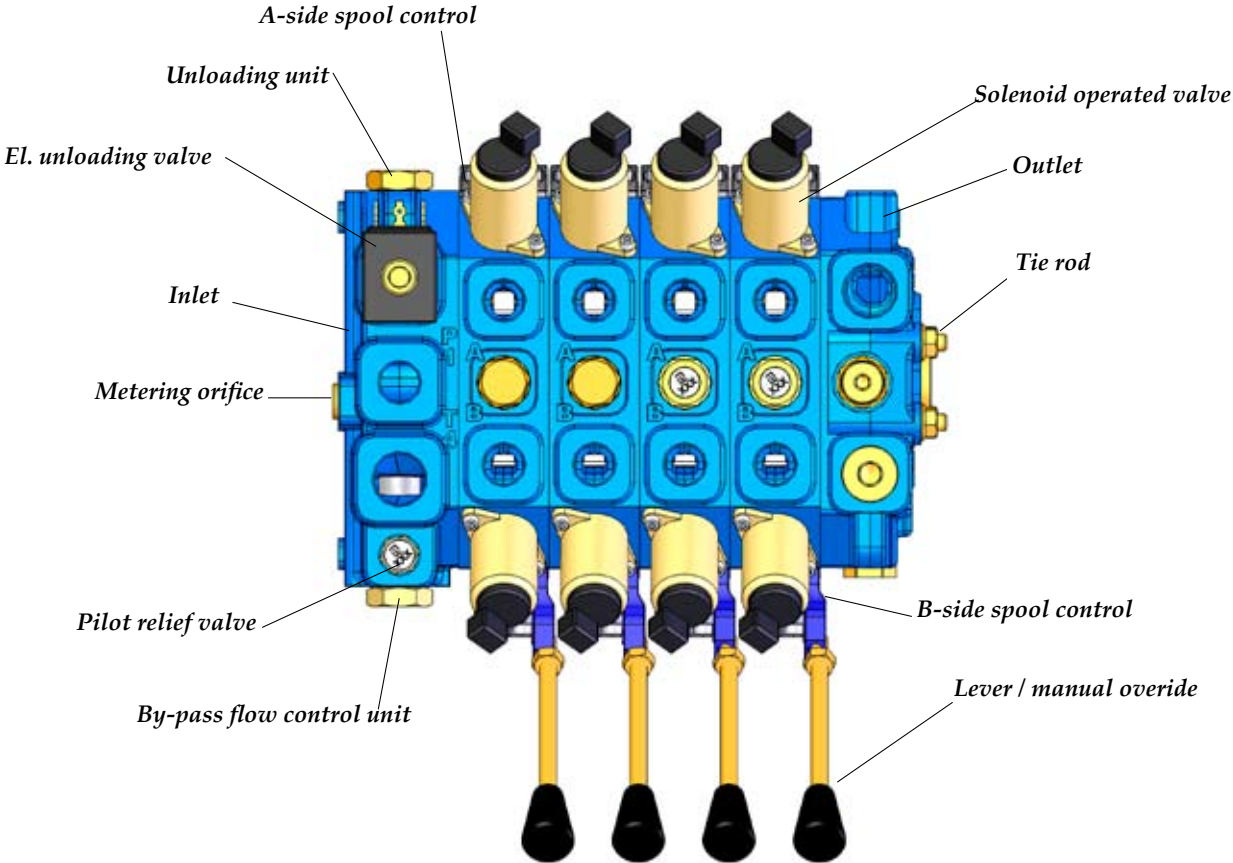

Technical data

Pressures / flow

Max. system pressure: 350 bar (35,0 MPa)
 Max continuous return line pressure..... 20 bar (2,0 MPa)
 Max. return line pressure, pilot oil circuit 5 bar (0,5 MPa)
 Rated flow..... 80 l/min

* Depending on application

Further data

Spring force for spool control 901 in neutral position:
 110 N (11,0 kp).

Spring force for spool control 901 with fully selected
 spool: 130 N (13,0 kp).

Recommended contamination level at normal duty: equal
 to or better than 18/14 as per ISO 4406.

At higher system pressure and/or for remote control:
 equal to or better than 17/13 as per ISO 4406.

Hydraulic fluid viscosity range at continuous operation:
 10-400 mm²/s(cSt). Higher viscosity allowed at start up.

Mineral oil and synthetic oil based on mineral oil are
 recommended.

Max. hydraulic fluid temperature range for continuous
 operation: -15°C - + 80°C.

Spool leakage at 100 bar, 32 cSt and 40°C: ≤13 cm³/min.

Attention:

*To ensure proper function of remote control systems
 it is very important that the acceptable level of
 contamination is not exceeded.*

Technical data - Pressure drop

Pressure drop P - T, unloaded valve

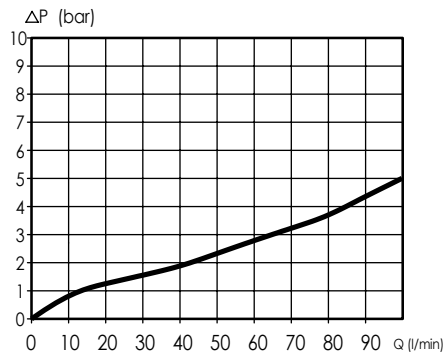

The pressure drops P - T are valid for a valve with a
 metering orifice PF305 for the centre channel flow. Note that
 a valve in unloaded mode will have a small flow in the centre
 channel.

Pressure drop P - T (idling)

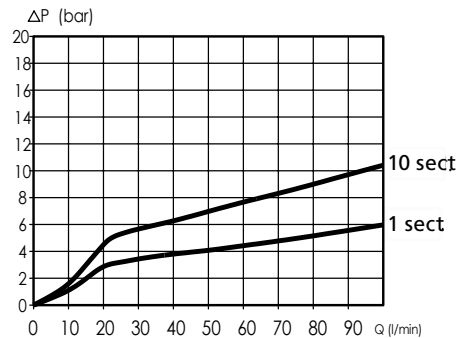

Oil temperature/viscosity for
 all graphs: + 50°C / 32 cSt

Pressure drop P-A/B

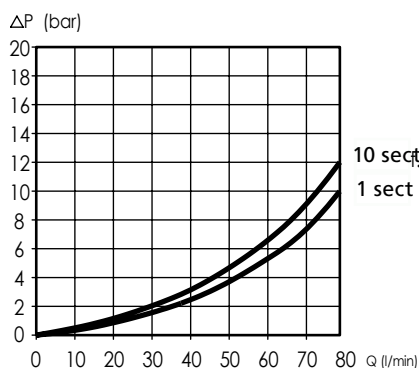

Note that the pressure drop curves P - A/B and A/B - T are
 valid for sections equipped with spools that are fully open at
 maximum spool travel.

Pressure drop A/B-T

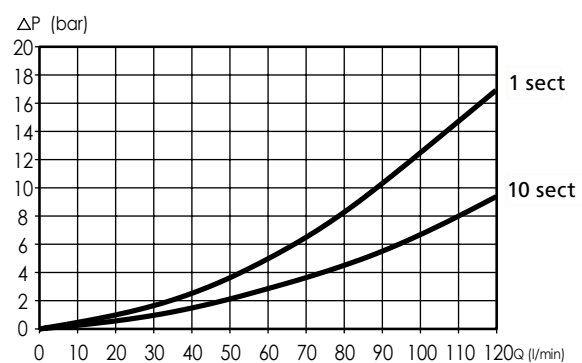



Technical data - Dimensions, weight

RS 220

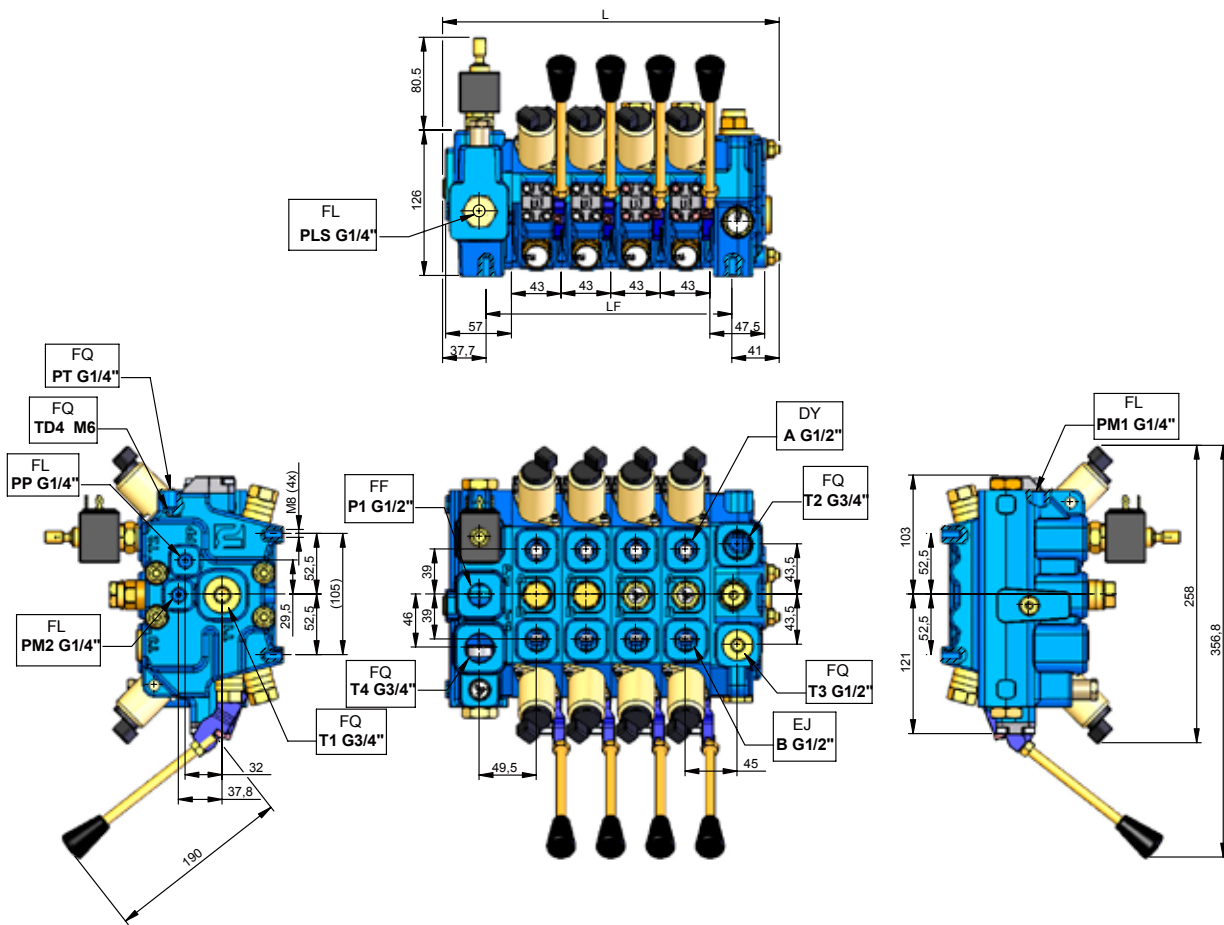

Weight

- Inlet section..... 6,3 kg
- Working section 5,0 kg
- Outlet section..... 4,6 kg

Dimensions

No. of working sections	L mm	LF mm
1	163	84
2	206	127
3	249	170
4	292	213
5	335	256
6	378	299
7	421	342
8	464	385
9	507	428
10	550	471

Electrical unloading

Data

- Power consumption..... 17 W
- Rated voltage 12 or 26 V
- Max voltage variation +/- 10%
- Duty factor 100%
- Connection..... Hirschmann ISO 4400-DIN 43650
- Protection class IP65
- The unloading valve has manual override.

Codes

- E912push and twist type override 12 V
- E926.....push and twist type override 26 V



Inlet section - with flow control and electrical unloading

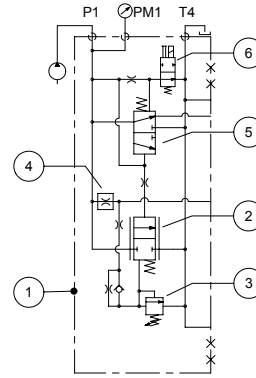
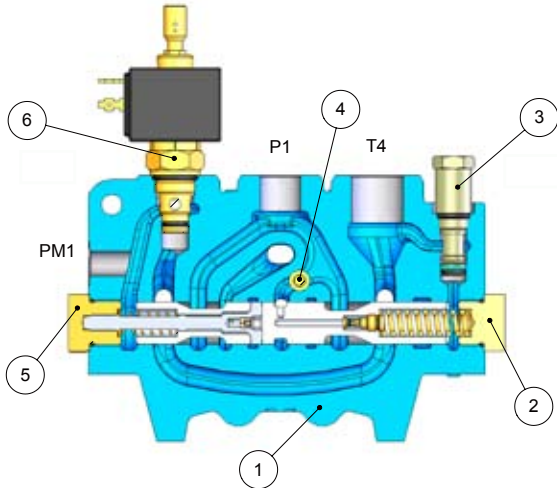

Main relief function

The by-pass flow control valve FK301 in combination with the relief valve TB12 form the pilot operated relief valve function of the inlet section for the primary circuit (valid for all configurations).

TB12 is adjustable and sealable.

Setting range: 35-350 bar (3,5 - 35,0 MPa).

Setting range step: 5 bar.

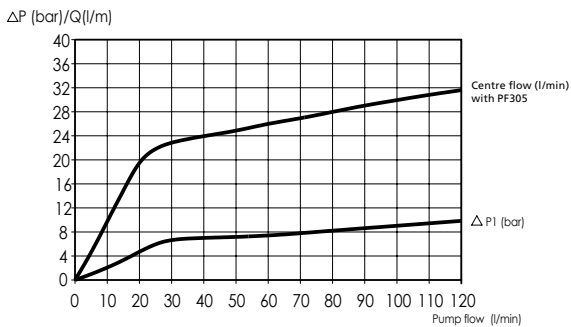
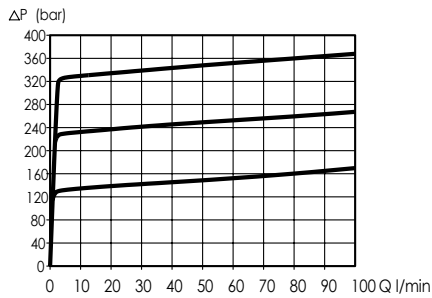

- 1. Inlet.....I01G
- 2. By-pass flow control unit.....FK301
- 3. Pilot relief valve TB12
- 4. Metering orifice for centre channel flow..... PF305
- 5. Unloading unit..... FU301
- 6. Solenoid operated valve E926

The I01G with its integral Q-function provides by-pass of pump flow to tank in idling condition, thereby reducing pressure drop and heat generation. The flow control function of the inlet also regulates the flow to the user corresponding to the travel of a partially selected spool. This, in addition to reduced flow forces and a control response to large extent unaffected by varying pump flows, contributes to the excellent operating characteristics achievable with RS 220.

An integral and from the flow control separated spool, together with a solenoid operated electrical unloading valve, unloads the pump flow to tank and disconnects the oil supply to the valve sections.

Together with a load holding valve RS 220 achieves a very safe emergency dump of pump oil to tank.

The regulated flow into the centre channel is set by an exchangeable metering orifice.

The opening of the by-pass flow control spool is cushioned by a special check valve integrated in the spool.



Inlet section - with flow control and without unloading

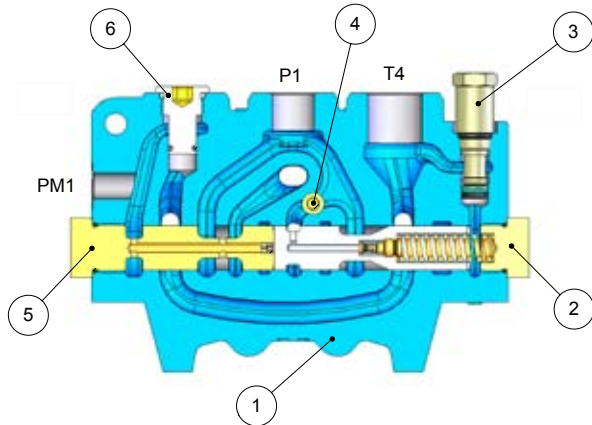

The inlet can also be delivered without the unloading function. The unloading spool and the solenoid operated valve in that case are replaced by plugs.

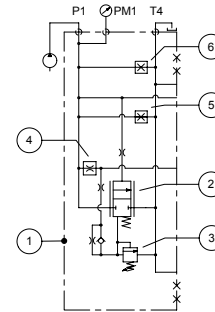

- 1. InletI01G
- 2. By-pass flow control unit FK301
- 3. Pilot relief valve TB12
- 4. Metering orifice for centre channel flow PF305
- 5. Plug replacing unloading unitPU300
- 6. Plug replacing electrical unloading valve..... PE20

Inlet section - variable displacement

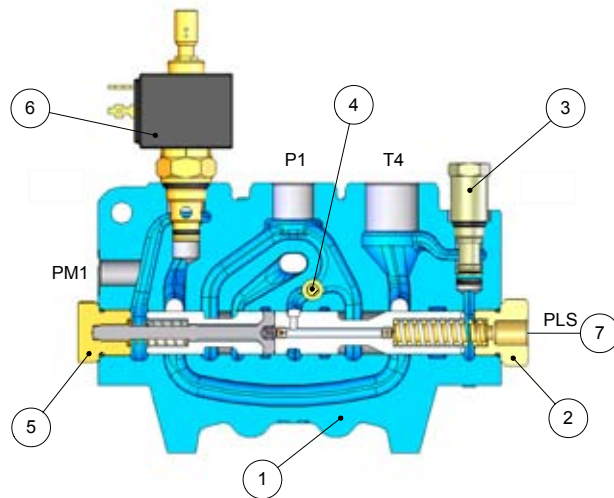

The I01G inlet can also be used in valves in systems with variable displacement pumps. The pump has to be of type LS-regulated.

The inlet configured for variable pumps provides a modified Q-function. When the system is idling the pump delivers a regulated flow to the centre channel. The regulated flow is set by the combination of metering orifice and actual stand-by pressure from the pump.

The maximum system pressure preferably is set in the pump but as an extra safety the inlet is equipped with a pilot operated primary relief valve.

As the regulated flow is set by the combination of metering orifice and the stand by pressure, it is important to match the metering orifice to the actual pump.

Use PF302 if the stand-by pressure is 14 bar, PF303 if it is 20 bar and PF304 if it is 24 bar .

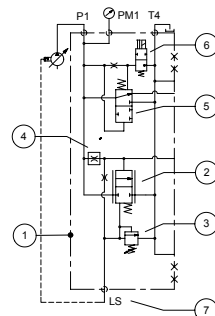

- 1. InletI01G
- 2. Primary relief valve..... FK310
- 3. Pilot relief valve TB12
- 4. Metering orifice for centre channel flow PF302
- 4. Metering orifice for centre channel flow..... PF303
- 4. Metering orifice for centre channel flow..... PF304
- 5. Shut off unit.....FU302
- 6. Solenoid operated valve E926
- 7. LS port

Generally the stand-by pressure is significantly higher than the pressure drop over the metering orifice in an open centre system and this means that the metering orifice in a system with variable pump has to be smaller.

An integral and from the relief valve separated spool, together with a solenoid operated valve, shuts off the oil supply to the valve sections.

Together with a load holding valve this achieves emergency shut off of the oil supply.

Working section - manually operated

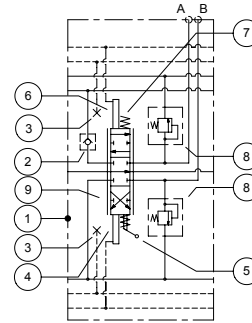
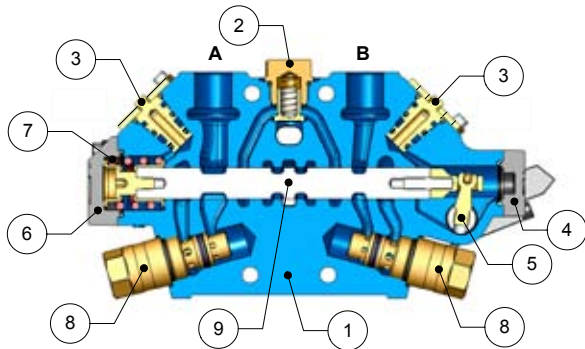

Section S01G equipped as manually operated. Existing cavities for solenoid valves are fitted with plugs (PE11) which connect (drain) the spool ends to tank. That is necessary since no spool seals separate the return line galleries from the spool ends. This feature provides very good protection for spool ends (ideal for marine use) and minimizes external leakage risks.

- 1. Section S01G
- 2. Load check valve MB22
- 3. Plug PE11
- 4. Spool control, B-side B01
- 5. Lever mechanism LMA
- 6. Spool control, A-side 9
- 7. Centering spring for manual control MS
- 8. Service port valve TBD160
- 9. Spool

Working section - hydraulically operated

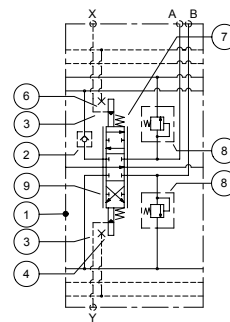
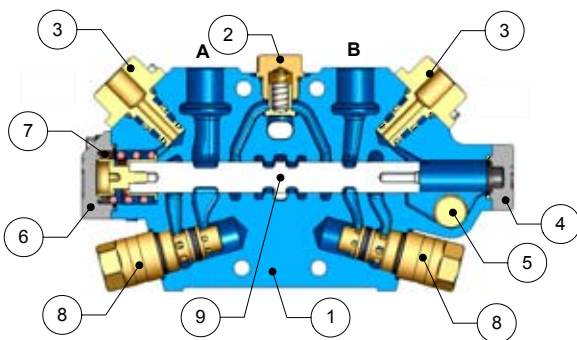

Section S01G equipped as hydraulically operated and without manual override. Adapters (HG10) are fitted into the solenoid valve cavities. They connect the pressure from a hydraulic control valve to the spool ends.

- 1. Section S01G
- 2. Load check valve MB22
- 3. Adapter for hydraulic remote control HG10
- 4. Spool control B-side B01
- 5. Plug, replacing lever mechanism PM02
- 6. Spool control A-side 9
- 7. Centering spring for proportional control PS
- 8. Service port valve TBD160
- 9. Spool



Working section - electro-hydraulically

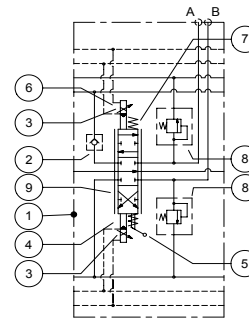
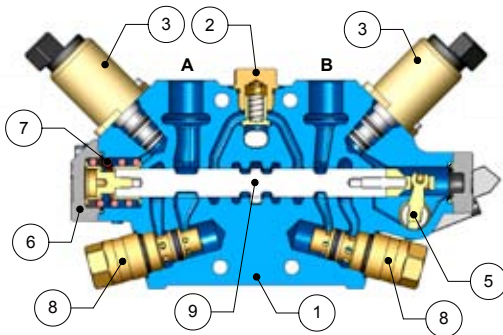

Section S01G equipped as electro-hydraulically operated and with manual override. The mechanism for the manual override is an option and can be replaced by a plug.

It is possible to mix valve sections that are configured for the different types of controls.

The centering springs are specified separately.

- 1. SectionS01G
- 2. Load check valveMB22
- 3. Solenoid operated valve for proportional controlER54
- 4. Spool control on B-sideB01
- 5. Lever mechanismLMA
- 6. Spool control A-side9
- 7. Centering spring for proportional controlPS
- 8. Service port valveTBD160
- 9. Spool.....

Load check valve

The main function of the load check valve is to prevent the load from moving backwards if the load pressure is higher than pump pressure when operating.

MB22

Load check valve.

MF22

Load check valve with adjustable flow limitation. MF22 maximizes the flow out from a section. Typical application is a slewing function.



Check valve MF22

MP22

Plug without load check valve. This option is usable for example when the function is equipped with pilot operated load holding valves.

Solenoid valve for EHP - ER52 / 54

ER52/54

ER52/54 are 3/2-way electrically operated pressure reducing valves used to provide controlled pilot pressure to operate valve spools.

- Functional principlePWM (Pulse Width Modulation)
- Duty factor100%
- ConnectionAMP Junior-Power-Timer
- Recommended PMW frequency100 Hz
- Protection classIP 65
- Ambient temperature- 30°C-+ 80°C

Note: If used as "on-off" it is recommended to limit the current by using for example a coupling resistance. Please contact Nordhydraulic for detailed information.



ER52

- Rated voltage(+/- 2V)12 V DC
- Starting current500 mA
- Fully shifted1200 mA
- Coil resistance + 20°5,4 Ohm

ER54

- Rated voltage (+/- 4V)24 V DC
- Starting current250 mA
- Fully shifted600 mA
- Coil resistance + 20°21,7 Ohm

Outlet section - without internal pilot oil supply function

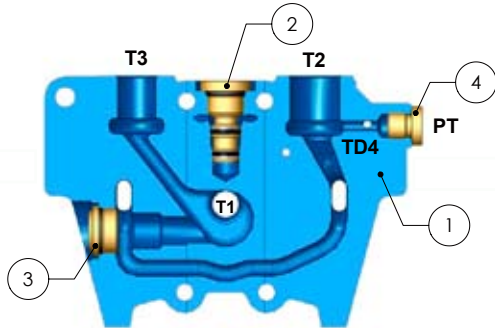

Outlet U01G equipped for hydraulically or manually operated sections.

The cavity for the pressure reducing valve is plugged, P63.

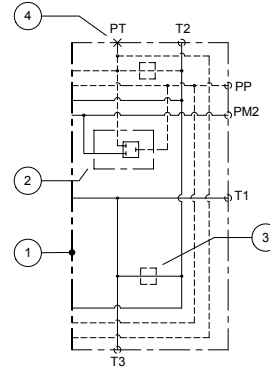

- 1. Outlet U01G
- 2. Plug P63
- 3. Plug PK400
- 4. Plug PG02

Outlet section - with high pressure carry-over function

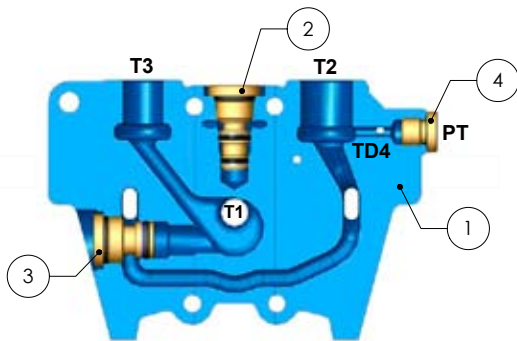

Outlet U01G equipped for hydraulically or manually operated sections and for high pressure carry-over function. Note that the carry-over flow is the flow that is regulated into the centre channel i. e. the flow that is determined by the metering orifice of the inlet section. With PF305 - 25 l/min. The plug P400 is fitted. High pressure carry-over ports can be either T1 or T3. The cavity for the pressure reducing valve is plugged with plug P63. Only T2 can be used as tank connection.

If in this case the plug P400 is replaced by the relief cartridge TBD160, it functions as relief valve for downstream services.

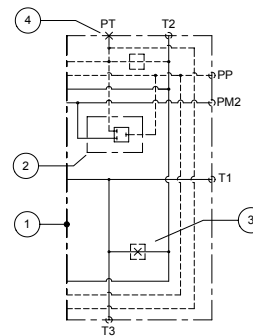

- 1. Outlet U01G
- 2. Plug P63
- 3. Plug P400
- 4. Plug PG02

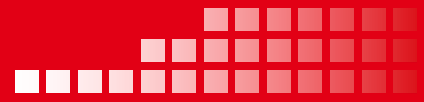

Outlet section - with internal pilot oil supply function

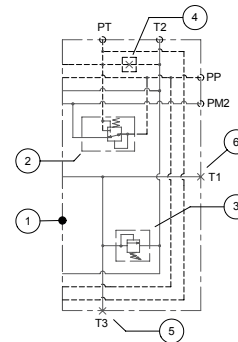
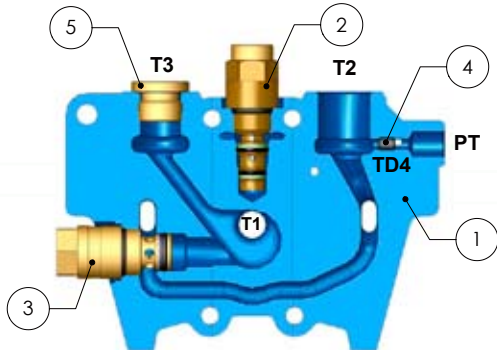

Outlet U01G equipped for use in an electro hydraulically operated valve. The outlet is configured for pilot supply to the valve sections.

An initial pressure is built up by a pilot pressure valve in the centre channel. Ports T1 and T3 have to be plugged.

The pilot pressure is limited by a pressure reducing valve connected to the parallel channel. Due to the fact that the unloading unit in the inlet shuts off the flow supply to the parallel channel an emergency stop will also shut off the oil supply to the pilot circuit.

The return flow from the spool controls and the pressure reducing valve is preferable drained directly to tank in a separate piping. In order to achieve this it is recommended to use PT and plug the connection between pilot drain and ordinary tank line.

- 1. Outlet U01G
- 2. Pilot pressure reducing valve TRA63
- 3. Pilot pressure valve TMB210/2
- 4. Plug for isolate pilot drain from ordinary tank line PMS6
- 5. Plug in T3 PG04
- 6. Plug in T1 PG06

Pilot pressure valve TMB210/2

The cartridge type pilot pressure valve TMB210/2, normally set at minimum 14 bar, is used in outlet section to secure available pilot pressure build-up for remote control. Depending on system design this necessary starting pressure could also be achieved through downstream arrangements, for example a support leg valve.

TMB210/2 is adjustable and sealable.



Pressure reducing valve TRA63

The cartridge type pressure reducing valve TRA63 is used in the outlet to provide pilot oil supply for remote control.

TRA63 is fixed set at 24 bar which consequently is the maximum available pressure level in the pilot system.



Spool controls - A-side

Spool control 9

Spring centered.

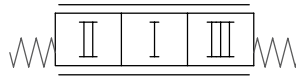

Spool control LA

External hydraulic kick-out from spool position III to I.

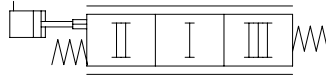

Spool control for remote control

Electro hydraulic control is achieved by using spool controls in combination with solenoid valves ER52/54 both on A-side and B-side.

The control will be proportional with the spring PS.

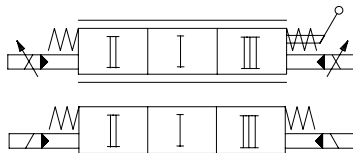

The control will be on-off in combination with the spring MS.

Hydraulic control is achieved by using spool controls in combination with adapters HG10 both on A-side and B-side.

The control will be proportional in combination with the spring PS.

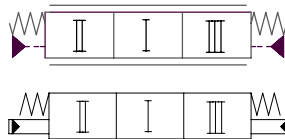

The control will be on-off in combination with the spring MS.

Spring - spool control

Type of centering spring has to be specified in the valve configuration

- MS *spring for manual operation*
Forces 110-130 N
- PS *spring for proportional remote control*
Forces 120-320 N



Spool controls - B-side

Spool control B01

Cap.

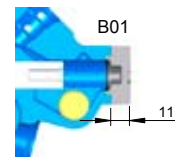
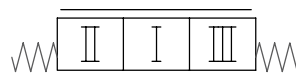

Spool control LB01

External hydraulic kick-out from spool position II to I. For sections with lever mechanism.

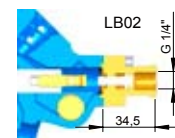
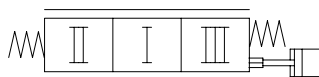

Note: Lever mechanism/cavity plugs as shown in pictures above are independent items to be separately configurated.



Lever mechanism on B-side

LMA2...LME2

Mechanism with lever holder but without lever. The lever MS190 has to be ordered as a separate item. The third letter in the code gives the angle for the assembly of the lever holder.

LM2

Lever mechanism without lever holder, lock nut and handle.

PM02

Plug replacing lever mechanism.

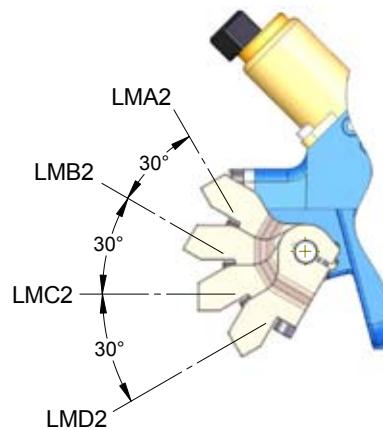

Spools - main design parameters

The RS 220 spools are available in a variety of flows and styles to accommodate most design requirements. The spool matrix configurator below will help and guide you to select the correct spool for your application. The development of new spools is a

continuous process and all available spools are not described in this data sheet. For further details on spools please contact Nordhydraulic.



Spool code

1 6 K A A

Type	Symbol	Type of application	Detailed demands
		A Spool general use K Crane optimized L Loader optimized	A Standard Example: - Restricted flow - Asymmetric - Spool end
Spool 1		Pump flow, Q-inlet 6 30 - 50 l/min 8 50 - 75 l/min	Function A Standard S X Y Z
Spool 2			
Spool 3			
Spool 4			
Spool 8			

Service port valves

Port relief valve TBD160

The TBD160 is a differential area, direct acting relief valve, for the secondary circuit. It is adjustable and sealable.

Setting ranges for TBD/TBSD160:

35 -300 bar (3,5 - 30,0 MPa).

Setting range step: 5 bar.

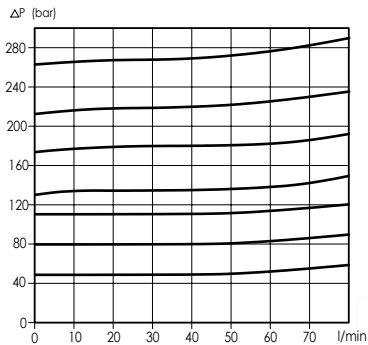
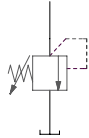

Relief characteristics TBD/TBSD160

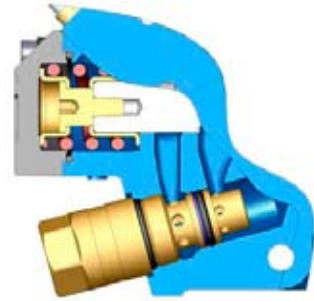

Port relief and anticavitation valve TBSD160

See TBD160 for functional principle.

TBSD160 is adjustable and sealable.

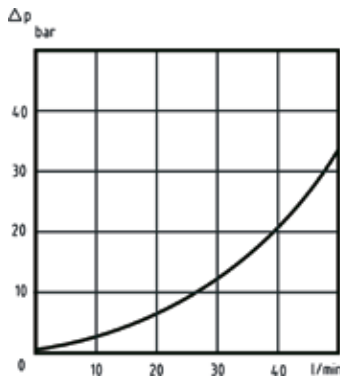
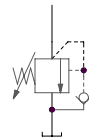

Anticavitation characteristics TBSD160



Port relief and anticavitation valve TBS400

Combination of pilot operated relief and anticavitation valve.

TBS400 is adjustable and sealable.

Setting range:

35- 350 bar (3,5 - 35,0 MPa).

Setting step: 5 bar.

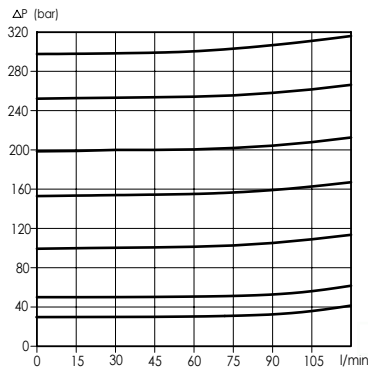
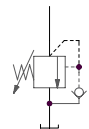

Relief characteristics TBS400

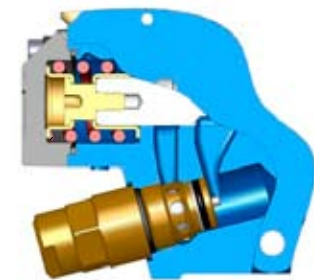

Anticavitation valve SB500

The anticavitation valve service to ensure that, in the event of a lower pressure in the cylinder port than in the tank, oil can be drawn from the system oil tank to the consumer.

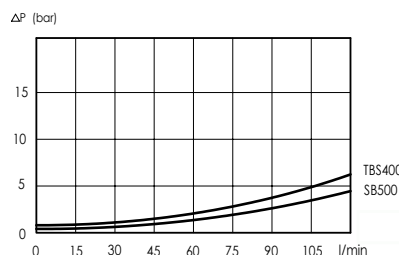

Anticavitation characteristics TBS400 and SB500

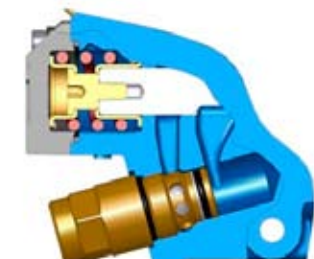



Typical hydraulic circuit diagrams

RS 220

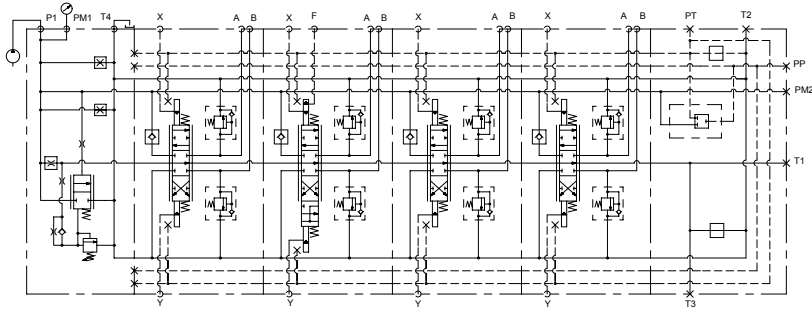

Hydraulic remote controlled valve.
2:nd section with 4-position spool.
Single circuit.
Inlet with flow control but without unloading.

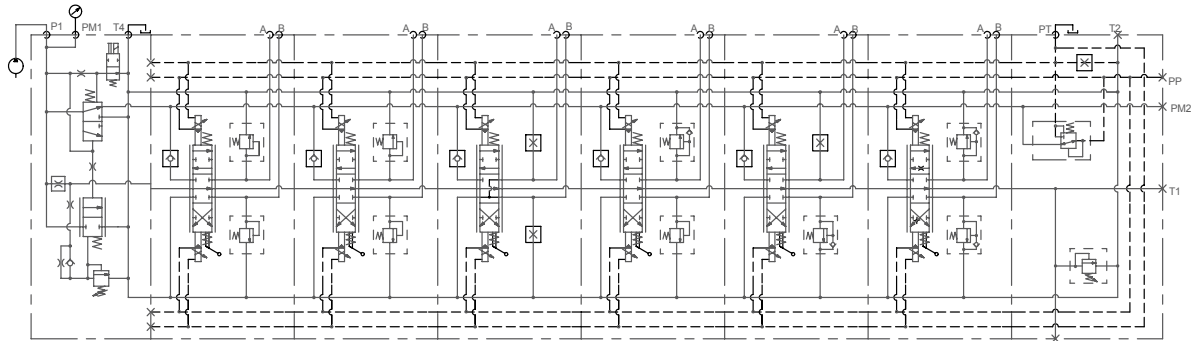

Electro hydraulic remote controlled valve with internal pilot supply.
Single circuit. Inlet with flow control and unloading.

