



# Nordhydraulic

HYDAC INTERNATIONAL

## Directional control valve RS 280



Solutions that power your visions

### Nordhydraulic AB

P.O Box 189 (Industrivägen 15)  
SE-872 24 KRAMFORS  
Sweden

Telephone: Int. +46 612 71 72 00  
Telefax: Int. +46 612 71 72 15

E-mail: [info@nordhydraulic.se](mailto:info@nordhydraulic.se)  
Web: [www.nordhydraulic.se](http://www.nordhydraulic.se)

**Data sheet**

**Directional control valve / RS 280**

## RS 280

### Make use of the Nordhydraulic expertise

Our skilled and experienced design and application engineers are at your disposal, helping you to specify the valve configuration that meets your application requirements.

### Key valve features

RS 280 is a sectional valve designed for system pressures up to 300 bar and pump flows up to 160 l/min.

It is available with 1 to 10 working sections per valve assembly.

RS 280 is designed with an open centre for fixed displacement pumps.

The valve can be operated manually, by pneumatic, electro-pneumatic or hydraulic remote control.

The valve offers excellent operating characteristics because of the specially designed spools for different applications.

Low and uniform spool forces are the result of careful balancing of the flow forces.

### Applications

Typical applications for RS 280 are cranes, tippers, truck loaders, backhoe loaders and wheel loaders.

### Further RS 280 properties and possibilities

- Many varieties of spools and spool controls make the valve suitable for a wide range of applications.
- Each section can be provided with a pressure relief valve, an anti-cavitation valve or a combination of these.
- Possibility of high pressure carry-over.
- With combination of an intermediate section there is the opportunity to realize different system alternatives, for example dual pump circuits, built in one compact valve.



### Data sheet

This data sheet presents a selection of standard components and how to specify these in a valve assembly according to your application requirements. For further information on RS 280 and available components, please contact Nordhydraulic.



**Table of contents**

*Technical data* page 4  
*Technical data, dimensions, weight* page 5  
*Main relief valves* page 6  
*Relief valves* page 7  
*Spool controls* page 8  
*Spools* page 9  
*System alternatives* page 10 - 11  
*High pressure carry-over* page 12  
*Hydraulic diagrams* page 12

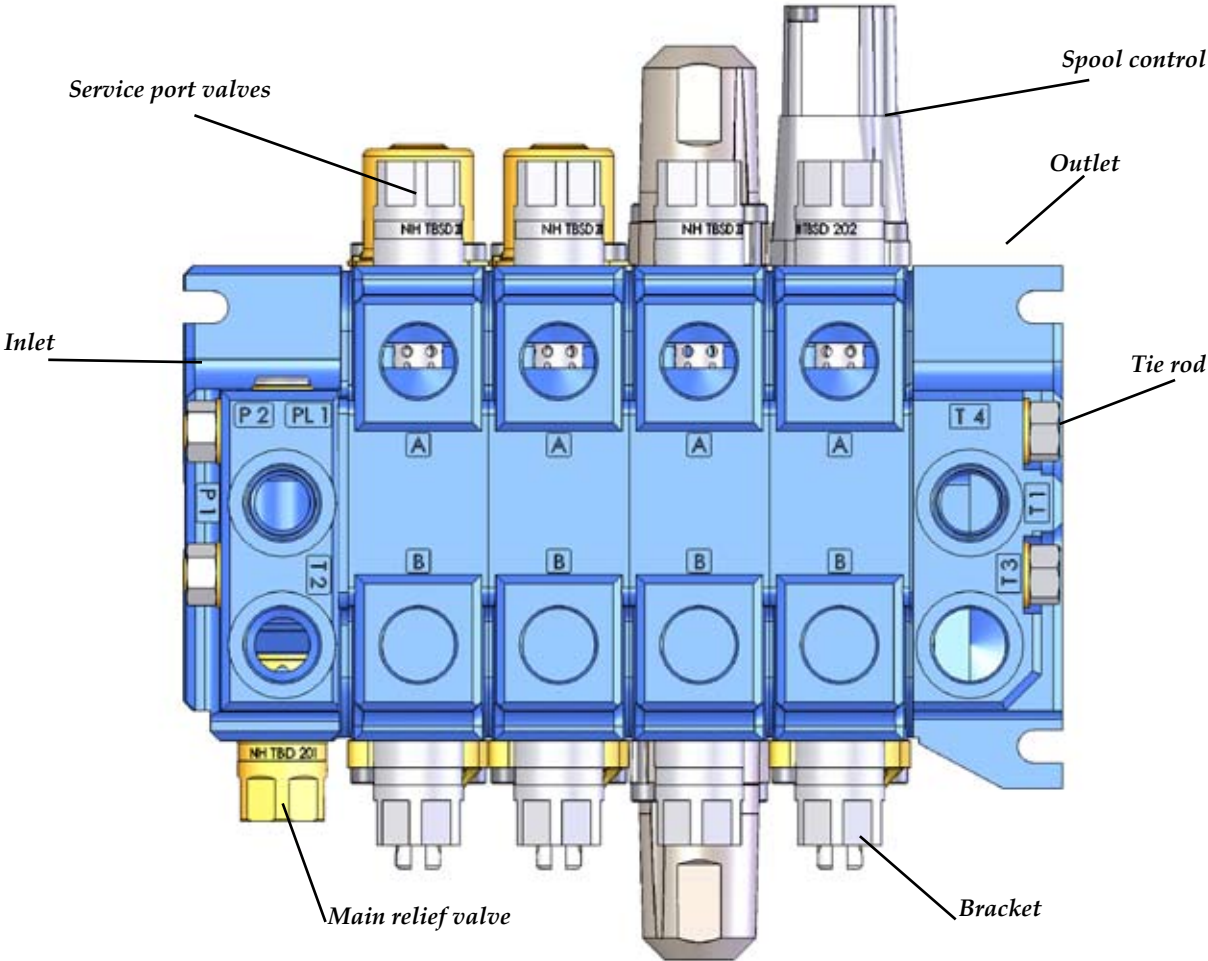

# Technical data

## Pressures / flow

Max. system pressure\* ..... 300 bar (30,0 MPa)  
 Max continuous return line pressure..... 20 bar (2,0 MPa)  
 Rated flow..... 120 l/min

\* depending on application

## Further data

Spring force for spool control 9 in neutral position:  
 110 N (11 kp).

Spring force for spool control 9 with fully selected spool:  
 140 N (14 kp).

Recommended contamination level at normal duty: equal to or better than 18/14 as per ISO 4406.

Hydraulic fluid viscosity range at continuous operation: 10-400 mm<sup>2</sup>/s(cSt). Higher viscosity at start up.

Mineral oil and synthetic oil based on mineral oil are recommended.

Max. hydraulic fluid temperature range for continuous operation: -15°C - + 80°C.

Spool leakage at 100 bar, 32 cSt and 40°C: < 18 cm<sup>3</sup>/min.

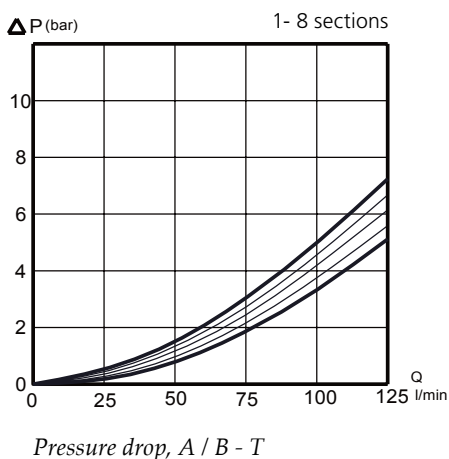
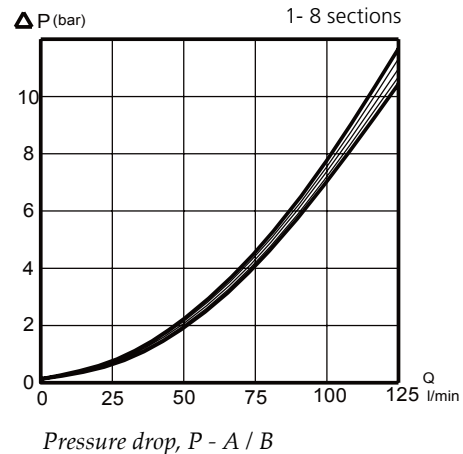
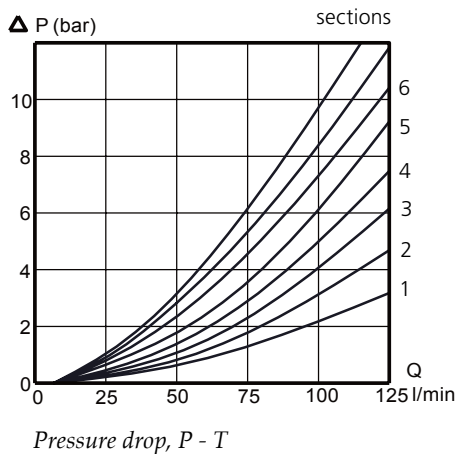

Oil temperature/viscosity for all graphs: + 50°C / 32 cSt



# Technical data - Dimensions, weight

RS 280

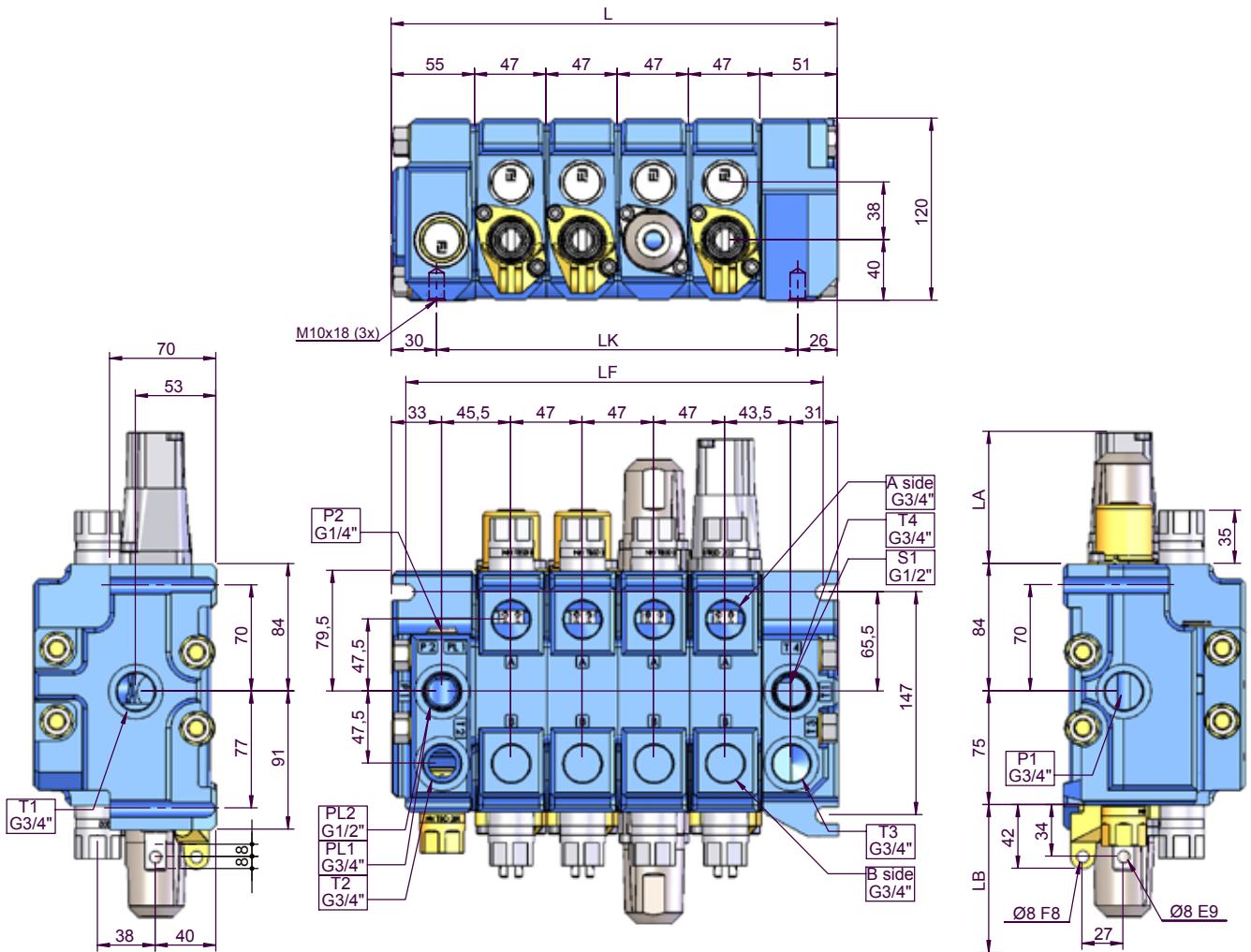

- Weights:**
- Inlet section ..... 4,4 kg
  - Outlet section ..... 5,0 kg
  - Working section ..... 5,0 kg
  - Intermediate section ..... 4,4 kg

Measurements			
No. of sections	L mm	LF mm	LK mm
1	153	134	97
2	200	181	144
3	247	228	191
4	294	275	238
5	341	322	285
6	388	369	332
7	435	416	379
8	482	463	426
9	529	510	473
10	576	557	520

Type	LA mm	Type	LB mm
910	40,5	M1	42
10	87	M2	15
11	87	M3	52
13	87	3W	92
14	87	4W	102
L81-83	105	HPD1B	72
P	103		
EP	134		
HPD1A	72		
HPD405	107,5		

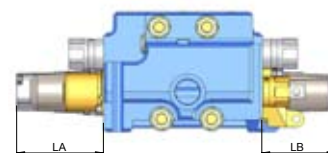

# Main relief valves

## Main relief valve TBD201

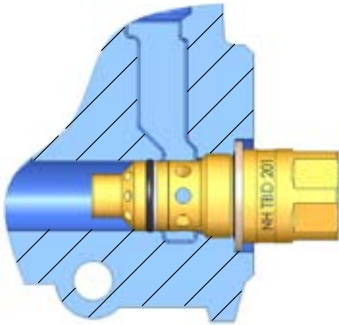

The TBD201 is a differential area, direct acting relief valve, for the main circuit. It is adjustable and sealable.

Setting range: 35 - 300 bar  
(3,5 - 30,0 MPa).  
Setting range step: 5 bar.

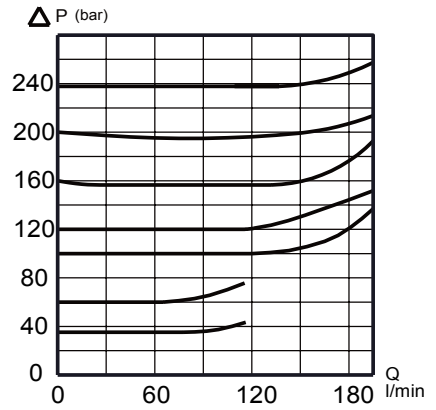
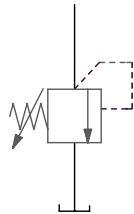

## Main relief valve TBS400

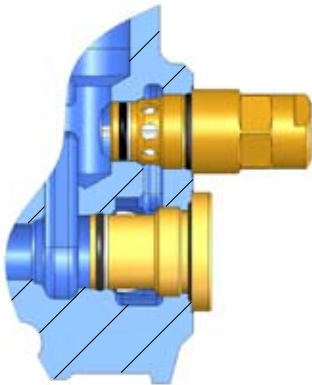

Pilot operated relief valve for the intermediate section. It is adjustable and sealable.

Setting range: 35 - 350 bar (3,5 - 35,0 MPa).  
Setting range step: 5 bar.

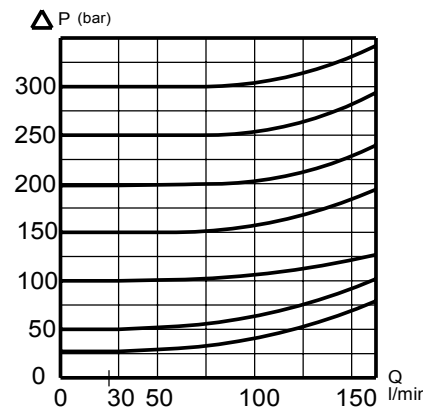
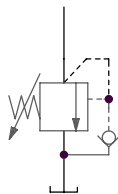



# Service port valves

## Port relief valve TBD202

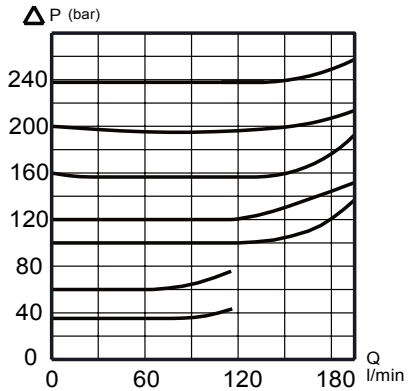

The TBD202 is a differential area, direct acting relief valve for the secondary circuit.

It is adjustable and sealable.

Setting range: 35 - 300 bar (3,5 - 30,0 MPa).

Setting range step: 5 bar.

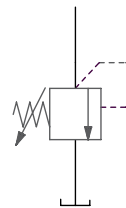
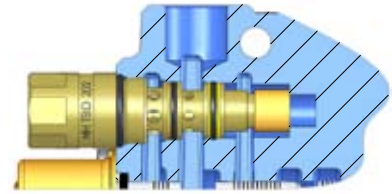

## Port relief and anticavitation valve TBSD202

Characteristics: See particulars of the port relief valve and the anti-cavitation valve.

The TBSD202 is a differential area, direct acting relief and anticavitation valve, for the secondary circuit.

It is adjustable and sealable.

Setting range: 35 - 300 bar (3,5 - 30,0 MPa).

Setting range step: 5 bar.

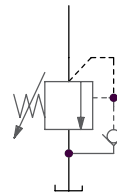
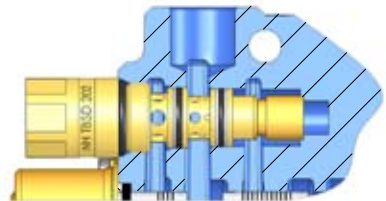

## Anticavitation valve SB250

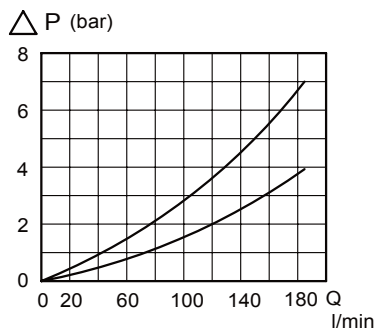

The anticavitation valve service to ensure that, in the event of a lower pressure in the cylinder port than in the tank, oil can be drawn from the system oil tank to the consumer.



## Spool controls - A-side

### Spool control 9

9 Spring centering.

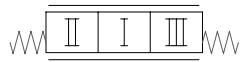

### Spool control HPD1

Hydr. proportional. Pilot pressure 6-16 bar. Max pilot pressure 25 bar.



### Spool control 10

Detents at positions 1, 2 and 3.



### Spool control HPD405

Hydraulic proportional spool control with float in 4:th position.



### Spool control 11

Spring centering with detent at position 4.



### Spool control L81

External hydraulic kickout from inserted spool \*\*\*.



### Spool control 13

Spring centering with detent at position 2.



### Spool control L82

External hydraulic kickout from extended spool\*\*\*.



### Spool control 14

Spring centering with detent at position 3.



### Spool control L83

External hydraulic kick-out from inserted and extended spool\*\*\*.



### Spool control P

Pneumatic\*.



\* Connection G 1/8" BSP

### Spool control EP

Electro/pneumatic on/off\*\*.



\*\*\* Connection G 1/4" BSP

\*\*

Power consumption.....	4,8 W
Rated voltage .....	24 V
Max voltage variation .....	+/- 10%
Duty factor .....	100%
Connection .....	according to EN175301-803/B
Protection class.....	IP65

## Spool controls - B-side

### Bracket M1

Bracket for 3-position spool.

### 3W

Cap for 3-pos. spool controlled by cable.

### Bracket M2

Bracket for 3-position spool without ear.

### 4W

Cap for 4-pos. spool controlled by cable.

### Bracket M3

Bracket for 4-position spool.



# Spools

	<p><b>Spools for general use</b></p>	
	<p><b>Function</b></p>	<p><b>Code</b></p>
	<p>Double acting spool</p>	<p>1X</p>
	<p>Single acting spool P - A</p>	<p>2X</p>
	<p>Double acting spool with 4th pos. for float</p>	<p>3X</p>
	<p>Motor spool</p>	<p>4X</p>
	<p>Motor spool A - T</p>	<p>4XA</p>
	<p>Motor spool B - T</p>	<p>4XB</p>

The RS 280 spools are available in variety of flows and styles to accommodate most design requirements. Since the development of spools is a continuous process and all available spools are not described in this data sheet, contact Nordhydraulic for advice on choosing spools in order to optimize your valve configuration.

Generally the spools are divided in 6 different flow ranges. The letter indicating flow ranges is replaced by X. D = 60 l/min, F = 70 l/min, H = 80 l/min, G = 90 l/min, K = 120 l/min, Q = 160 l/min. In the table only the accessibility of different functions are shown.

# System alternatives

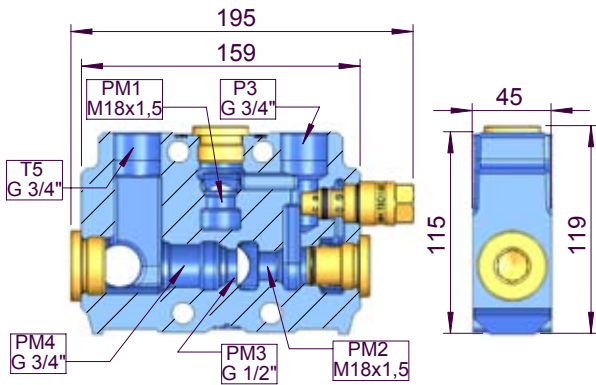

The intermediate section allows a number of different internal and external system alternatives.

Existing valve equipped with the intermediate section can easily be altered to other system configurations without dismantling the valve.

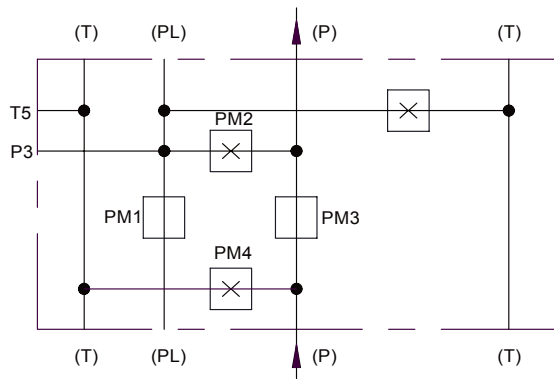

## K1, Single circuit

Valve internally parallel coupled.

Main relief valve for the system can be positioned in the intermediate section.

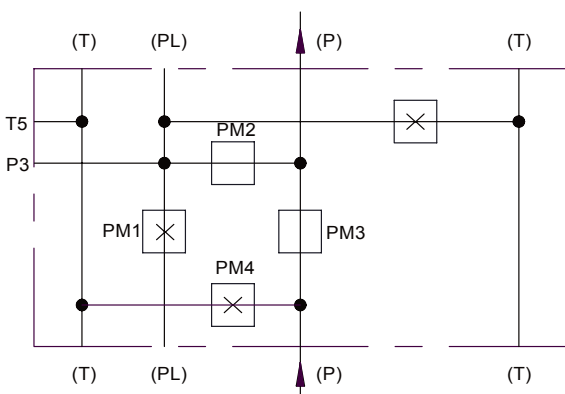

## K2, Single circuit

Valve internally tandem coupled, i.e. working sections upstream of the intermediate section with fully selected spools have complete priority as far as flow supply is concerned in relation to working sections downstream of the intermediate section.

A second main relief valve, positioned in the intermediate section, can be used to reduce the pressure to working sections downstream from the intermediate section.



# High pressure carry-over

## High pressure carry-over plug PS28

Plug PS28, mounted in S1 allows carry-over function.

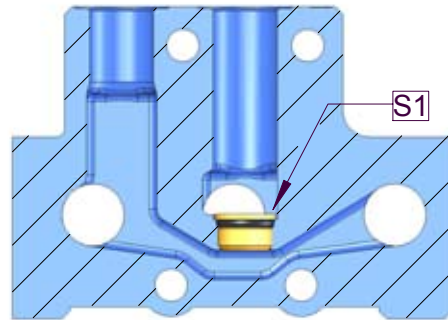

# Typical hydraulic circuit diagrams

Diagram 1: High pressure carry-over

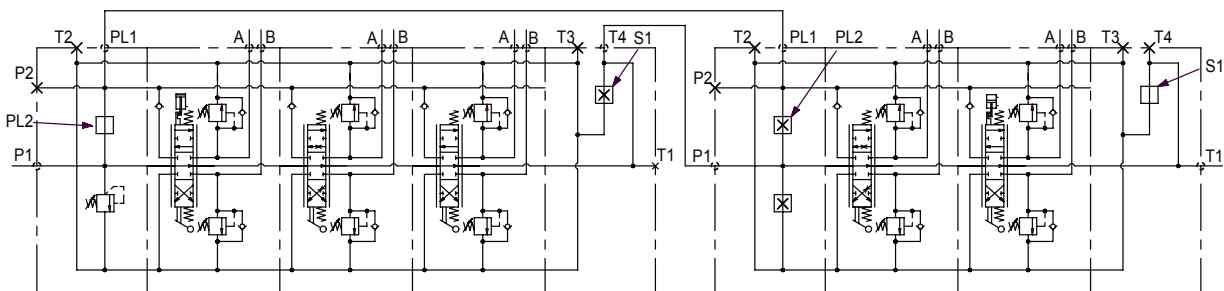

Diagram 2: Dual pump circuit with intermediate section (K3)

