



Metal Bellows Accumulator for Heavy Diesel Engines

1. DESCRIPTION

In the fuel injection system of heavy diesel engines (e.g. marine engines and engines for power plants / two and four-stroke), pressure fluctuations are generated during the injection process by the high pressure pumps.

In most heavy diesel engines each cylinder has its own injection pump. During the phases of fuel extraction from the supply line, compression and injection as well as the release of unused fuel into the return line, cyclic pressure pulsations may result.

Example:

$$\frac{600 \text{ [rpm]} \times 8 \text{ [cylinders]}}{60 \text{ [s]} \times 2 \text{ [4-stroke]}} = 40 \text{ [Hz]}$$

The supply line and the return line are at a lower pressure than the required injection pressure and in such dual-pipe systems the above-mentioned pressure fluctuations can cause problems, depending on the size of the pressure variations. It is for this reason that superimposed pressure fluctuations from 0 to approx. 13 bar can occur in a 4.5 bar return line (see the graph at Point 2). In other systems pressure peaks of over 50 bar have been measured.

This fluctuating pressure with its unacceptable pressure peaks not only creates an additional stress on the pipe system but also an additional load for all integrated fittings and devices. Valves, filters, measurement and monitoring devices, e.g. viscosity meters, ... can be seriously impaired or damaged, sometimes even irreparably.

Until now a standard method for reducing or eliminating the pulsations has been to use hydraulic accumulators with nitrogen as the damping element and an elastomer diaphragm or bladder as the separating element between the gas and the fuel. The best damping results may be obtained by installing one damper in the supply line and one in the return line close to the engine. However, such standard diaphragm and bladder accumulators have two main limitations:

Problems with elastomer resistance to fuels and high temperatures

Fuels other than diesel oil, such as bio-oils or heavy fuel oil require higher injection temperatures. These can reach 160°C. Also, the FKM (Viton®) used for the diaphragm or bladder leads to compatibility problems under such extreme conditions.

Gas loss through the elastomer

The accumulator gradually loses gas through the elastomer and the higher the temperature the higher the gas loss. If it is not possible to recharge the accumulator regularly, its function will deteriorate and the diaphragm or bladder will split.

These last two disadvantages can only be prevented by a relatively high investment in monitoring and maintenance. Depending on the type of fuel and its operating temperature, it can be necessary to replace the elastomer part after specific intervals.

HYDAC set itself the task of developing a pulsation damper without the problems outlined and which above all would also avoid the problems generated by other solutions (e.g. piston accumulators, spring-actuated accumulators, accumulators with elastic damping elements inside). These solutions have problems either with friction and abrasion or fuel leakage. One of the prime targets was therefore to relieve the system operator of the burden of excessive monitoring and maintenance.

The recently developed solution from HYDAC is the Metal Bellows Accumulator. Instead of a bladder or diaphragm, a metal bellows is used as the flexible separating element between fluid and gas. This bellows is resistant to all conventional fuels over a very wide temperature range. Heavy fuel oil at temperatures of up to 160°C is no problem for these dampers. The metal bellows is welded to the other components and is therefore gas-tight. It is able to move up and down inside the accumulator without any friction or abrasion and it can operate for a very long time (years) with just one adjustment. Monitoring and maintenance for this type of damper is therefore reduced to a minimum.

A diverting block is built into the fuel side of the damper which forces the fuel directly into the accumulator, thereby increasing the damping efficiency considerably. If two dampers are fitted to the fuel system (in both supply and return line), no pressure fluctuations can leave the engine before passing through one of the metal bellows dampers.

With this metal bellows accumulator, HYDAC has developed a competitively-priced damper which is without rival in terms of maintenance. The purchase costs will be recouped within a short time and as a result of reduced maintenance, the availability of the entire system is increased.

For further benefits, see below:

1.1. BENEFITS OF THE SM50P-...

- Maintenance-free
 - extremely gas-tight
 - frictionless parts (non-wearing)
- Fluid resistant across whole temperature range
- Competitively-priced: "fit and forget"

2. PRESSURE GRAPH

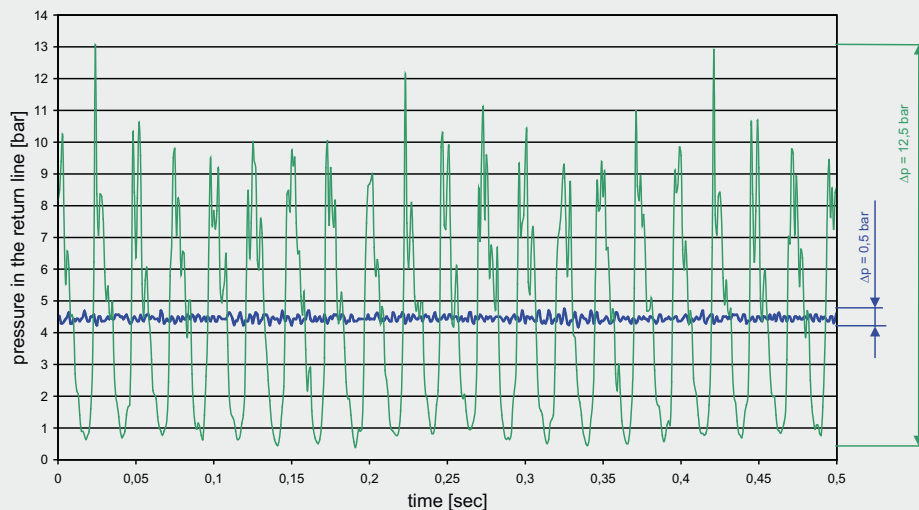

green = without damper
blue = with damper

3. INSTALLATION OF THE SM50P-...

3.1. DIAGRAM

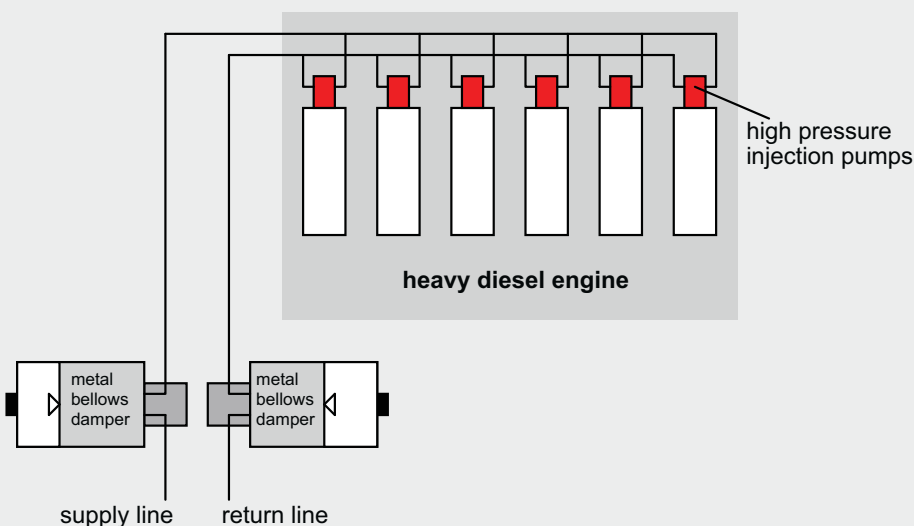

3.2. MODEL

3-D standard model, e.g. for inline installation.



Special connections on request

4. SPECIFICATIONS

4.1. TECHNICAL SPECIFICATIONS

Operating pressure:

3 ... 12 bar (others on request)

Max. pre-charge pressure:

4 bar (at max. operating temperature)

Design temperature range:

-10 °C ... +160 °C

Operating fluids:

Diesel and heavy fuel oil, biofuels

Total volume:

3.8 litres

Effective gas volume:

0.5 litres (nitrogen)

Gas-side fluid pre-charge:

0.6 litres (ethylene glycol)

Fluctuating volume:

max. 0.04 litres (others on request)

Material:

Carbon steel (primed externally)

Design and certification:

PED / ABS / DNV / GL /

LR / BV / AS1210 / ...

Fluid connection:

SAE 1 1/4" - 3000 PSI

SAE 2" - 3000 PSI

SAE 3" - 3000 PSI

Gas connection:

M28x1.5 for Universal Charging and

Testing Unit FPU-1

Part no.: 3398235

Mounting position:

Vertical (gas connection at top)

Others on request

Weight:

22 ... 33 kg depending on the connection

size

4.2. MODEL CODE

(also order example)

SM50 P - 0.5 W E 1/ 116 U - 50 AAJ - 2.5

Type / Series**Type code**

— = accumulator without diverting block*

L = light-weight accumulator*

P = damper with diverting block

Capacity [l]**Type**

W = convoluted bellows

M = diaphragm bellows*

Type of shell

A = screw type

E = weld type*

G = formed type*

Type of gas-side connection

1 = gas pressure adjustable (M28x1.5)

2 = gas pressure pre-set, non-adjustable gas locking screw*

3 = gas pressure adjustable (M16x1.5)

Material code**Fluid connection**

1 = carbon steel

2 = carbon steel with corrosion protection

3 = stainless steel

Accumulator body

1 = carbon steel

2 = carbon steel with corrosion protection

4 = stainless steel

Seal material

0 = no seal

2 = NBR*

5 = low temperature NBR*

6 = FKM

Certification code

U = PED

For others, see catalogue section no. 3.000

Permitted operating pressure [bar]**Fluid connection**

See tables in catalogue section 3.301, Piston Accumulators

Pre-charge pressure p_0 [bar] at 20°C

If required, this must be stated at time of ordering

* currently only on request

4.3. DIMENSIONS

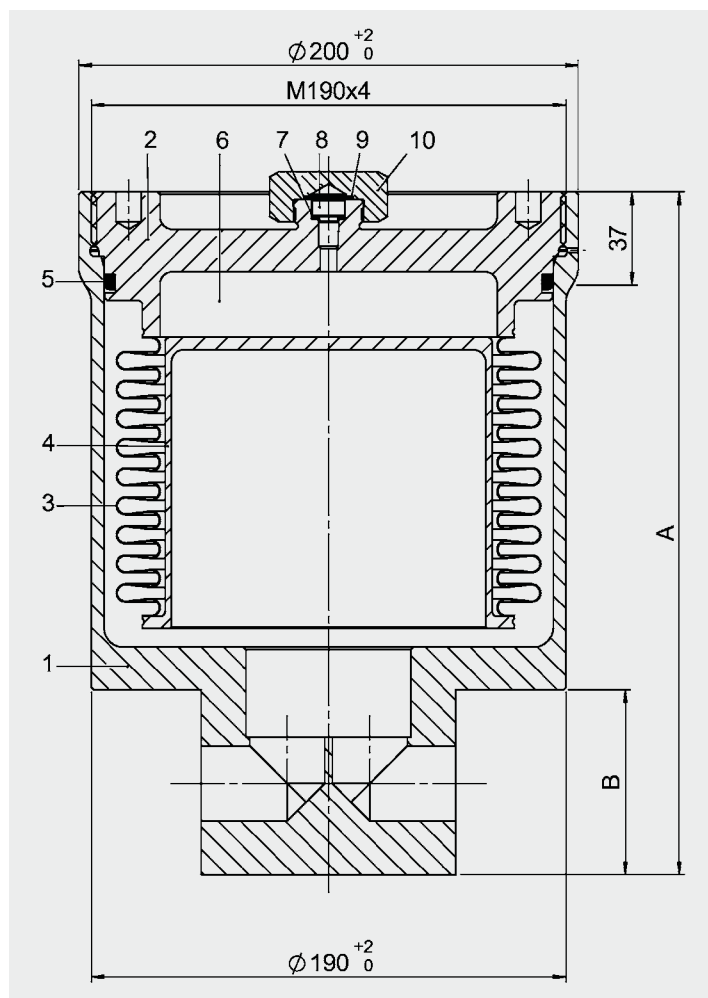

Item	Description
1	Accumulator lower section
2	Accumulator cover plate
3	Metal bellows
4	Bowl
5	O-ring
6	Nitrogen (N ₂) and Fluid (e.g. ethylene glycol)
7	Seal ring
8	Adjustable locking screw
9	O-ring
10	Protective cap

4.4. ACCUMULATOR CONNECTION

	Dimension [mm]		
	SAE 1 1/4" (FCD)*	SAE 2" (FCF)	SAE 3" (FCH)
A	274	294	333
B	74	94	134

* FCD = formerly AD

SM50P-3.8A6/116...FCD SAE 1 1/4" – 3000 psi

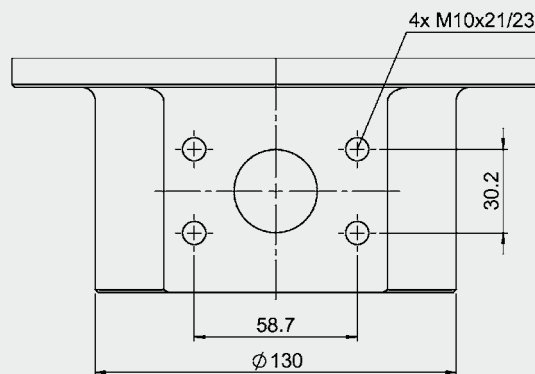

SM50P-3.8A6/116...FCF SAE 2" – 3000 psi

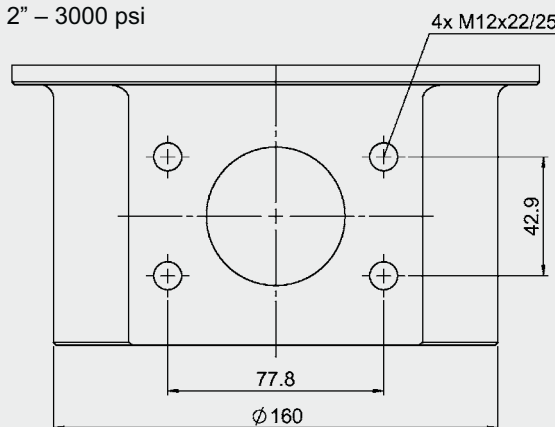

SM50P-3.8A6/116...FCH SAE 3" – 3000psi

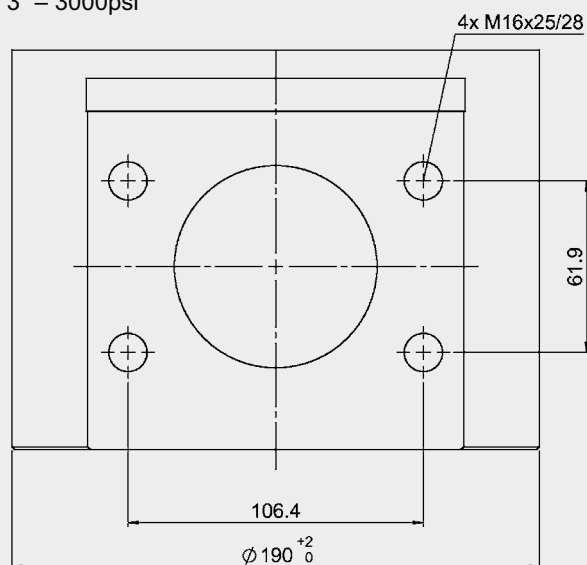

4.5. FLOW RATES / TEMPERATURE DEPENDENCY

Series SM50P-...	Bore	Max. flow rate Q_{max}	Weight	Ht.	Ext. diam. D_a	Max. operating temp. T_{max}	Max. pre-charge pressure $p_{0\ max}$ at 20°C	Min. operating pressure p_{min}
flange SAE [inch] - 3000 psi	[mm]	[m³/h]	[kg]	[mm]	[mm]	[°C]	[bar]	[bar]
1 ¼ ...FCD	30	< 8	22	274	200	30	4.0	$p_0 + 0.2$
2 ...FCF	50	8 - 21	25	294		45	3.8	$p_0 + 0.5$
3 ...FCH	73	> 21	33	333		65	3.6	$p_0 + 0.8$
						85	3.4	$p_0 + 1.2$
						105	3.2	$p_0 + 1.5$
						130	3.0	$p_0 + 1.9$
						160	2.8	$p_0 + 2.5$

* The pre-charge pressure (p_0) is based on the max. operating temperature and must be lower than the min. operating pressure.

4.6. BUTT WELD AND SOCKET WELD FLANGES

Pressure: 3000 PSI

Seal: Viton

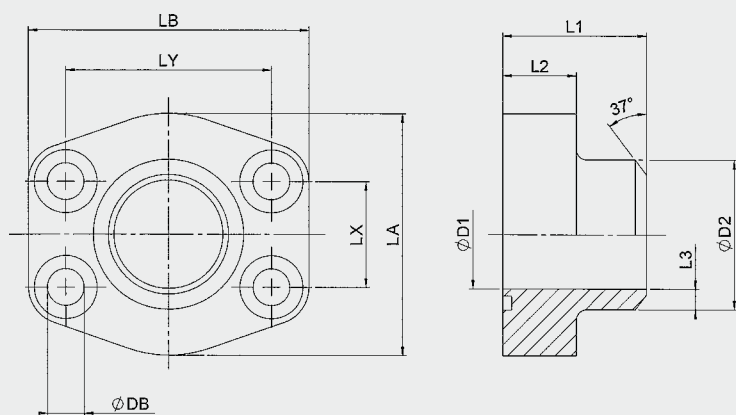

Series SAE [inch]	D1 [mm]	D2 [mm]	L1 [mm]	L2 [mm]	L3 [mm]	LA [mm]	LB [mm]	LX [mm]	LY [mm]	DB [mm]	Screws
1 ¼	31	42.8	41	21	3.0	< 74	≅ 80	30.2	58.7	10.5	M10x40
2	50	61.0	45	25	5.5	< 94	≅ 103	42.9	77.8	13.5	M12x45
3	73	89.0	50	27	8.0	< 134	≅ 135	61.9	106.4	17.0	M16x50

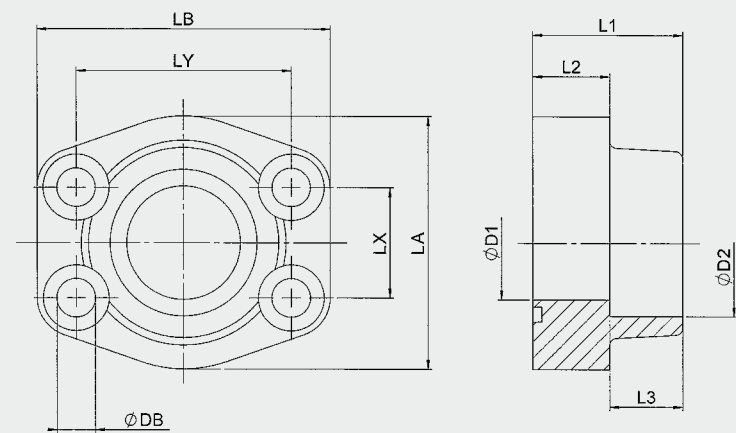

Series SAE [inch]	D1 [mm]	D2 [mm]	L1 [mm]	L2 [mm]	L3 [mm]	LA [mm]	LB [mm]	LX [mm]	LY [mm]	DB [mm]	Screws
1 ¼	31	42.8	41	21	20	< 74	≅ 80	30.2	58.7	10.5	M10x40
2	50	61.0	45	25	24	< 94	≅ 103	42.9	77.8	13.5	M12x45
3	73	90.5	50	27	28	< 134	≅ 135	61.9	106.4	17.0	M16x50

5. NOTE

The information in this brochure relates to the operating conditions and applications described.

For applications and operating conditions not described, please contact the relevant technical department.

Subject to technical modifications.

HYDAC Technology GmbH
 Industriegebiet
D-66280 Sulzbach/Saar
 Tel.: 0 68 97 / 509 - 01
 Fax: 0 68 97 / 509 - 464
 Internet: www.hydac.com
 E-Mail: speichertechnik@hydac.com

