

Electronic Pressure Switch

For shipbuilding and offshore
EDS 300

Description:

The EDS 300 is a compact, electronic pressure switch with digital display. The pressure measurement is based on a strain gauge sensor cell in stainless steel. All parts in contact with the fluid are in stainless steel, and are welded together. Since no seals are required in the sensor chamber, leakage is eliminated.

Two relay switching outputs with N/O function and an additional analogue output signal (4 .. 20 mA) enable the pressure switch to be incorporated into the most modern control concepts. The switching points and the corresponding hystereses can easily be adjusted via the keypad.

For optimum adaptation to a particular application, the unit has many additional adjustment parameters, e.g. switching direction of the relays, switching delay times.

Areas of application are pressure or maximum value monitoring on marine transmissions, diesel engines, pumps and general hydraulic and pneumatic systems.

Approvals:

- American Bureau of Shipping
No.: 00-ES19976-X



- Lloyds Register of Shipping
No.: 00/20048



- Det Norske Veritas
No.: A-7710 (895.10)



- Germanischer Lloyd
No.: 15519-00HH



- Bureau Veritas
No.: 10343/A0BV



Other approvals on request.



Setting options:

All the settings available on the EDS 300 are combined in two easy-to-follow menus. To prevent unauthorised adjustment of the unit, a program disable can be activated.

Setting ranges of the switching points and/or switch-back hystereses:

Meas. range in bar	Switching pt. in bar	Hysteresis in bar	Increment* in bar
-1 .. 5	-0.85 .. 5	0.05 .. 5.9	0.05
0 .. 6	0.15 .. 6	0.05 .. 5.9	0.05
0 .. 16	0.3 .. 16	0.1 .. 15.8	0.1
0 .. 40	0.6 .. 40	0.2 .. 39.6	0.2
0 .. 100	1.5 .. 100	0.5 .. 99.0	0.5
0 .. 250	3.0 .. 250	1.0 .. 248	1.0
0 .. 400	6.0 .. 400	2.0 .. 396	2.0
0 .. 600	15.0 .. 600	5.0 .. 590	5.0

Meas. range in psi	Switching pt. in psi	Hysteresis in psi	Increment* in psi
-14 .. 75	-12.5 .. 75.0	-0.5 .. 74.0	0.5
0 .. 150	3 .. 150	1 .. 148	1
0 .. 1000	15 .. 1000	5 .. 990	5
0 .. 3000	45 .. 3000	15 .. 2970	15
0 .. 6000	90 .. 6000	30 .. 5940	30
0 .. 9000	150 .. 9000	50 .. 8900	50

* All ranges given in the table are adjustable by the increments shown.

Additional functions:

- Scale of the display range adjustable (bar, psi)
- Switching direction of the relays adjustable (pull-in or release when switching point is reached)
- Switch-on delay adjustable between 0.00 .. 75 seconds
- Switch-back delay adjustable between 0.00 .. 75 seconds
- Choice of display (actual pressure, peak value, switching point 1, switching point 2, display off)
- Subsequent correction of zero point in the range $\pm 3\%$ FS possible

Switching point / switch-back point:

The switching point is defined as being the pressure value, which when reached (whilst pressure is increasing), causes a change in the switching output.

This output state is maintained until the pressure falls below the switch-back hysteresis allocated to the switching point. The switch-back point is determined by the switch-back hysteresis which has been set (switching point minus switch-back hysteresis = switch-back point).

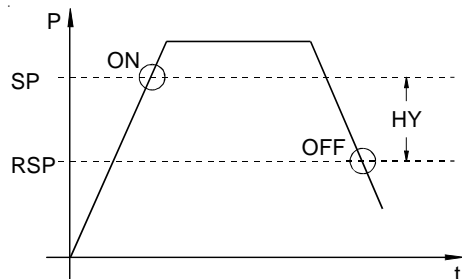

SP = switching point
 HY = switch-back hysteresis
 RSP = switch-back point
 (switching point minus switch-back hysteresis)

Pin connections:

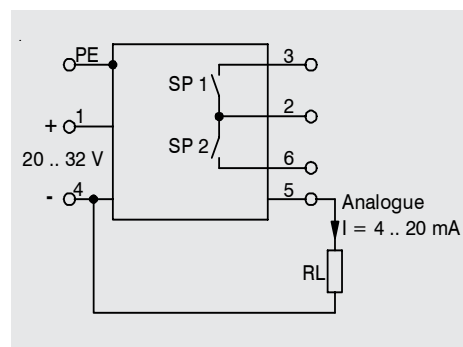

Electrical accessories:

ZBE 10

Right-angled connector (6 pole + earth) to DIN 43651 (not supplied)

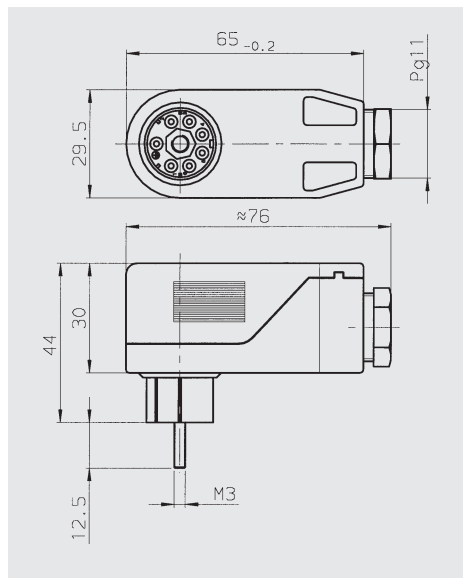

Mechanical accessories:

ZBM 14 connection adaptor G $\frac{1}{4}$ female thread - G $\frac{1}{4}$ A male thread for optimum alignment of the pressure switch

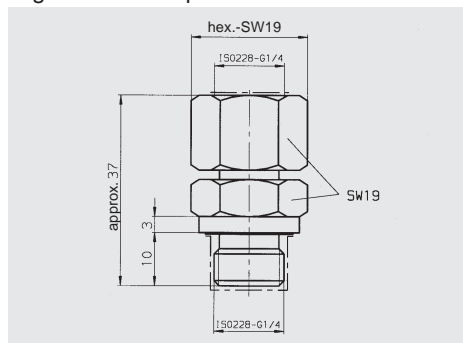

Seals:

Female thread: NBR

Male thread: NBR

ZBM 310 clamp for wall-mounting the EDS 300 (materials: polypropylene, aluminium AISi12, steel)

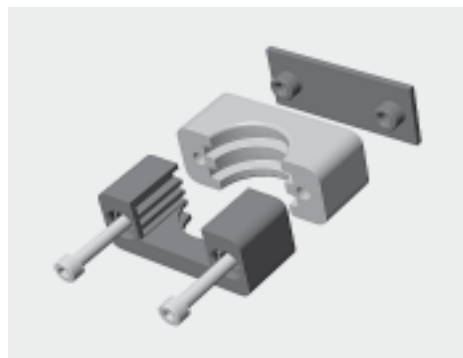

Technical specifications:

Input data:

Measuring ranges in bar:	-1 .. 5, 6, 16, 40, 100, 250, 400, 600 bar
Overload pressures in bar:	15, 15, 32, 80, 200, 500, 800, 900 bar
Measuring ranges in psi:	-14 .. 75, 150, 1000, 3000, 6000, 9000 psi
Overload pressures in psi:	200, 300, 3000, 7000, 11000, 13000 psi
Burst pressure:	400 % FS

Output data:

Accuracy (display, analogue output):	$\leq \pm 1$ % FS max.
Repeatability:	$\leq \pm 0.5$ % FS max.
Temperature drift:	$\leq \pm 0.3$ % / 10 K zero point max. $\leq \pm 0.3$ % / 10 K range max.
Analogue output:	4 .. 20 mA, ohmic resistance $\leq 400 \Omega$

Switching outputs:

Type:	2 relay contacts (N/O)
Switching voltage:	10 mV .. 60 V (AC or DC)
Switching current:	0.01 mA .. 1 A
Max. switching output:	30 W / 30VA (for inductive load, use varistors)

Life expectancy:	20 million (min. load) 0.5 million (max. load)
------------------	---

Reaction time:	approx. 10 ms
----------------	---------------

Ambient conditions:

Temperature range of medium:	-25 .. + 80 °C
Ambient temperature range:	-25 .. + 80 °C
Storage temperature range:	-40 .. + 80 °C
Nominal temperature range:	-10 .. + 70 °C

CE mark:	EN 61000-6-1, EN 61000-6-2 EN 61000-6-3, EN 61000-6-4
----------	--

Vibration resistance:	5 .. 25 Hz: 3.2 mm 25 .. 500 Hz: 4 g
-----------------------	---

Other data:

Supply voltage:	20 .. 32 VDC
Electrical connection:	plug to DIN 43651 (6 pole + earth)
Current consumption:	approx. 100 mA
Protection class:	IP 65
Hydraulic connection:	G $\frac{1}{4}$ A to DIN 3852, (torque rating approx. 20 Nm), SAE 4 female thread (torque rating approx. 8 Nm)

Parts in contact with fluid:	stainless steel, seal: FPM
------------------------------	----------------------------

Material of housing:	tube: stainless steel keypad housing: PA6.6 Gf30
----------------------	---

Display:	4-digit, 7 segment LED, red
----------	-----------------------------

Weight:	approx. 300 g
---------	---------------

Note: **FS (Full Scale)** = relative to the full measuring range

Mounting:

The EDS 300 pressure switch has a pressure connection with a G $\frac{1}{4}$ A male thread (DIN 3852) or SAE 4 female thread.

It is therefore possible to mount the pressure switch directly inline or onto a hydraulic block.

Using the ZBM 14 connection adaptor (only for G $\frac{1}{4}$ A male thread) ensures that the display is visible to the user.

When used in critical applications (e.g. strong vibrations or knocks) the EDS 300 must be mechanically decoupled. A clamp (ZBM 310) is therefore available for wall-mounting. In this case the pressure connection must be by means of a Minimes line.

Model code:

EDS 3 X 7-4 - XXX - S00 (PSI)

Series no. _____
(determined by manufacturer)

Type of connection, mechanical _____

- 4 = G 1/4 A male thread
- 5 = SAE 4 female thread

Type of connection, electrical _____

- 7 = 6 pole + earth
(connector ZBE 10 is not supplied)

Output _____

- 4 = 2 switching outputs and 1 analogue output

Measuring ranges _____

bar version, only in conjunction with connection thread G 1/4 A:

XXX = 006, 016, 040, 100, 250, 400, 600 with modification no. S00
for -1 .. 5 bar use "006" and modification no. S13

psi version, only in conjunction with connection thread SAE 4:

XXXX= 0150, 1000, 3000, 6000 with modification no. S40
for -14 .. 75 psi use "0089" and modification no. S41

Modification numbers _____

- S00 = bar version (except for -1 .. 5 bar)
- S13 = vacuum version -1 .. 5 bar
- S40 = psi version (except for -14 .. 75 psi)
- S41 = vacuum version -14 .. 75 psi

PSI = Additional code for psi version _____
(not required for bar versions)

Accessories available:

For the electrical connection:

ZBE 10 right-angled connector,
(6 pole + earth), DIN 43651

For the mechanical connection:

ZBM 14 connection adaptor for optimum
alignment of the pressure switch
clamp

ZBM 310 clamp for wall-mounting

Dimensions:

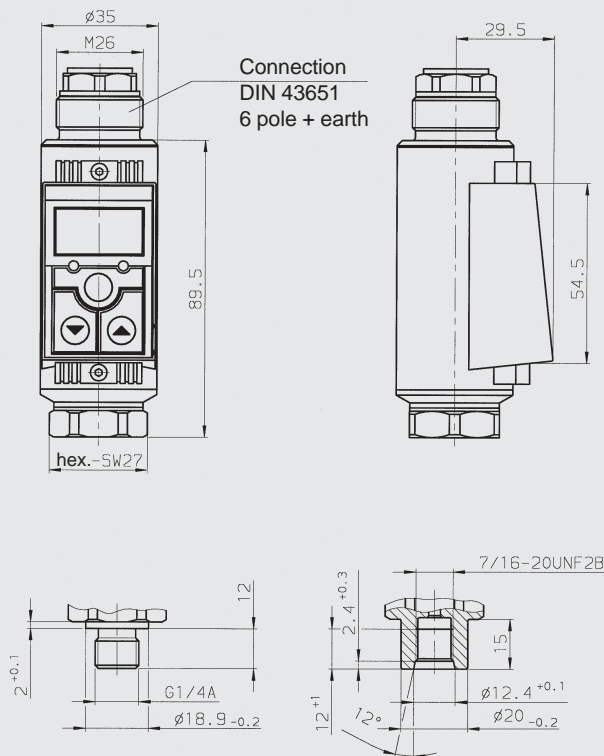

required mounting radius R36

Note:

The information in this brochure relates to the operating conditions and applications described. For applications or operating conditions not described, please contact the relevant technical department. Subject to technical modifications.