

# Hydraulic Bladder Accumulators

## Low Pressure

### 1. DESCRIPTION

#### 1.1. FUNCTION

Fluids are practically incompressible and cannot therefore store pressure energy.

The compressibility of a gas is utilised in hydro-pneumatic accumulators for storing fluids. HYDAC bladder accumulators are based on this principle, using nitrogen as the compressible medium.

The bladder accumulator consists of a fluid section and a gas section with the bladder acting as a gas-proof screen. The fluid around the bladder is connected with the hydraulic circuit, so that the bladder accumulator draws in fluid when pressure increases and the gas is compressed. When the pressure drops, the compressed gas expands and forces the stored fluid into the circuit.

HYDAC bladder accumulators can be used in a wide variety of applications, some of which are listed below:

- energy storage
- emergency operation
- force equilibrium
- leakage compensation
- volume compensation
- shock absorption
- vehicle suspension
- pulsation damping  
(see brochure on Hydraulic Dampers no. 3.701../..)



## 1.2. CONSTRUCTION

### 1.2.1 Construction

HYDAC low pressure bladder accumulators consist of a welded pressure vessel, a flexible bladder with gas valve and a hydraulic connection with check valve.

The table shows the different models which are described in greater detail in the pages that follow:

Designation	perm. press. [bar]	Volume [litres]	Flow [l/s]
SB40- 2.5... 50	40	2.5 - 50	5
SB40- 70... 220		70 - 200	30
SB35HB- 20... 50	35	20 - 50	70
SB16A- 100... 450	16	100 - 450	15
SB35A- 100... 450	35		70
SB16AH- 100... 450	16		
SB35AH- 100... 450	35		

### 1.2.2 Bladder materials

The following elastomers are available as standard:

- NBR (acrylonitrile butadiene rubber, Perbunan)
- IIR (butyl rubber)
- FKM (fluoro rubber, Viton®)
- ECO (ethylene oxide epichlorohydrin rubber).

The material used depends on the respective operating medium and temperature.

### 1.2.3 Corrosion protection

For use with chemically aggressive media the accumulator shell can be supplied with corrosion protection, such as plastic coating on the inside or chemical nickel plating.

If this is insufficient, then stainless steel accumulators must be used.

## 1.3. MOUNTING POSITION

HYDAC bladder accumulators can be installed vertically, horizontally and at a slant.

When installing vertically or at a slant, the oil valve must be at the bottom. On certain applications listed below, particular positions are preferable:

- Energy storage: vertical
  - Pulsation damping: any position from horizontal to vertical
  - Maintaining constant pressure: any position from horizontal to vertical
  - Volume compensation: vertical
- If the mounting position is horizontal or at a slant, the effective volume and the maximum permissible flow rate of the operating fluid are reduced.

## 1.4. TYPE OF MOUNTING

- For strong vibrations and volumes above 1 litre, we recommend the use of HYDAC accumulator supports or the HYDAC accumulator mounting set. (Brochures "Supports for Hydraulic Accumulators" no. 3.502. and ACCUSET SB, no. 3.503.)

## 2. TECHNICAL SPECIFICATIONS

### 2.1. EXPLANATORY NOTES

#### 2.1.1 Working pressure

See tables  
(in some countries this can differ from the nominal pressure)

#### 2.1.2 Nominal volume

See tables

#### 2.1.3 Effective gas volume

See tables,  
based on nominal dimensions; this differs slightly from the nominal volume and must be used when calculating the effective volume.

#### 2.1.4 Effective volume

The fluid volume available between the working pressures  $p_2$  and  $p_1$ .

#### 2.1.5 Max. flow rate of the pressure fluid

In order to achieve the max. flow rate given in the tables, the accumulator must be mounted vertically. It has to be taken into account that a residual fluid volume of approx. 10% of the effective gas volume remains in the accumulator.

#### 2.1.6 Fluids

The various seal and bladder materials are compatible with the following fluids:

Material	Fluid
NBR Low Temp NBR	Mineral oils (HL, HLP, HFA, HFB, HFC), water
ECO	Mineral oil
IIR	Phosphate ester, water
FKM	Chlorinated hydrocarbons, petrol

#### 2.1.7 Permissible operating temperature

The permissible operating temperatures are dependent on the application limits of the metallic materials and the bladders.

The standard valve bodies, gas valves and accumulator shells are suitable for temperatures -10 °C to +80 °C.

Outside these temperatures, special material combinations must be used. The following table shows the correlation between bladder material and application temperature.

Material	Temperature ranges
NBR	- 15 °C to + 80 °C
Low Temp NBR	- 50 °C to + 80 °C
ECO	- 30 °C to + 120 °C
IIR	- 40 °C to + 100 °C
FKM	- 10 °C to + 150 °C

#### 2.1.8 Gas charging

Always charge with 99.995% nitrogen only, filtered to < 3 µm.

If other gases are to be used, please contact HYDAC for advice.  
NEVER USE OXYGEN OR COMPRESSED AIR.

**RISK OF EXPLOSION.**

## 2.1.9 Critical values for gas pre-charge pressure

$$p_0 \leq 0.9 \times p_1$$

with a permissible pressure ratio of:

$$p_2 : p_0 \leq 4:1$$

$p_2$  = max. operating pressure

$p_0$  = gas pre-charge pressure

## 2.1.10 Certificate codes

Australia	F <sup>1</sup>
Brazil	U <sup>3</sup>
Canada	S1 <sup>2</sup>
China	A9
CIS	A6
EU member states	U
Hungary	U <sup>3</sup>
India	U <sup>3</sup>
Japan	P
New Zealand	T
Poland	A4
Romania	U <sup>3</sup>
Slovakia	A8
South Africa	U <sup>3</sup>
Switzerland	U <sup>3</sup>
USA	S

### others on request

- <sup>1</sup> = approval required in the individual territories  
<sup>2</sup> = approval required in the individual provinces  
<sup>3</sup> = alternative certificates possible

On no account must any welding, soldering or mechanical work be carried out on the accumulator shell. After the hydraulic line has been connected it must be completely vented.

Work on systems with accumulators (repairs, connecting pressure gauges etc) must only be carried out once the pressure and fluid have been released.

### Please observe operating instructions!

#### Note:

Application examples, accumulator sizing and extracts from approvals regulations on hydraulic accumulators can be found in the accumulator overview brochure no. 3.000../...

## 2.2. MODEL CODE

(also order example)

**SB 35 A - 100 F 7 / 112 U - 35 A**

### Series

### Type

H = high flow

N = increased flow, standard oil valve dimensions

A = shock absorber

B = bladder top-repairable

Combinations possible: e.g.

HB = High Flow with a top-repairable bladder

No details = standard

### Nominal volume in l

### Fluid connection

A = standard connection, thread with internal seal face

F = flange connection

C = valve mounting with screws on underside

E = sealing surfaces on the front interface (e.g. on thread M50x1.5 - valve)

G = male thread

S = special connection according to customer specification

### Gas side

1 = standard model

2 = back-up model

3 = gas valve 7/8-14 UNF with M8 female thread

4 = 5/8" gas valve

5 = gas valve M50x1.5 in accumulators smaller than 50 l

6 = 7/8-14 UNF gas valve

7 = M28x1.5 gas valve

8 = M16x1.5 gas valve

9 = special gas valve according to customer specification

### Material code <sup>1)</sup>

112 = standard for mineral oil

depending on operating medium

others on request

### Fluid connection

1 = carbon steel

2 = high-strength steel

3 = stainless steel <sup>3)</sup>

6 = low temperature steel

### Accumulator shell

0 = plastic coated (internally)

1 = carbon steel

2 = chemically nickel plated (internally)

4 = stainless steel <sup>3)</sup>

6 = low temperature steel

### Accumulator bladder <sup>2)</sup>

2 = NBR

3 = ECO

4 = IIR (butyl)

5 = TT-NBR (low temperature)

6 = FKM

7 = others

### Certificate code

U = PED 97/23/EC

### Permissible operating pressure (bar)

### Connection

Thread, codes for fluid connections: A, C, E, G

A = thread to ISO228 (BSP)

B = thread to DIN13 or ISO965/1 (metric)

C = thread to ANSI B1.1 (UN...-2B seal to SAE J 514)

D = thread to ANSI B1.20.1 (NPT)

S = special thread according to customer specification

Flange, codes for fluid connection: F

A = DIN flange

B = flange ANSI B 16.5

C = SAE flange 3000 psi

D = SAE flange 6000 psi

S = special flange according to customer specification

**Required gas pre-charge pressure must be stated separately!**

<sup>1)</sup> Not all combinations are possible

<sup>2)</sup> When ordering spare bladders, please state bladder connection port size

<sup>3)</sup> Depending on type and pressure rating

### 3. LOW PRESSURE ACCUMULATORS

#### 3.1 STANDARD BLADDER ACCUMULATORS SB40-2.5 ... 50

##### 3.1.1 Construction

HYDAC standard low pressure accumulators consist of:

- A welded pressure vessel which can be treated with various types of corrosion protection for chemically aggressive fluids, or can be supplied in stainless steel.
- A bladder with gas valve. The bladders are available in the elastomers listed under point 2.1.
- A hydraulic connector with a perforated disc which is held in place with a retaining ring.

#### 3.1.2 Dimensions SB40 - 2.5 ... 50

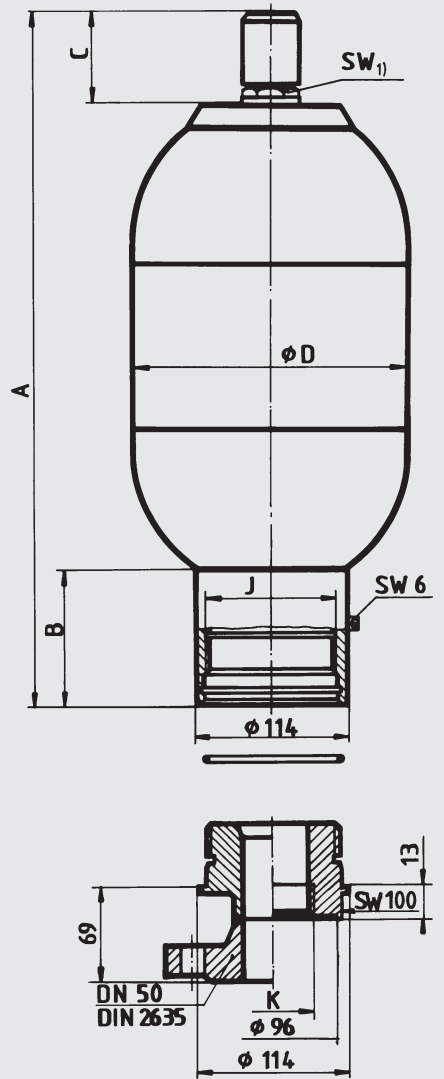

#### 3.1.3 Spare parts SB40 - 2.5 ... 50

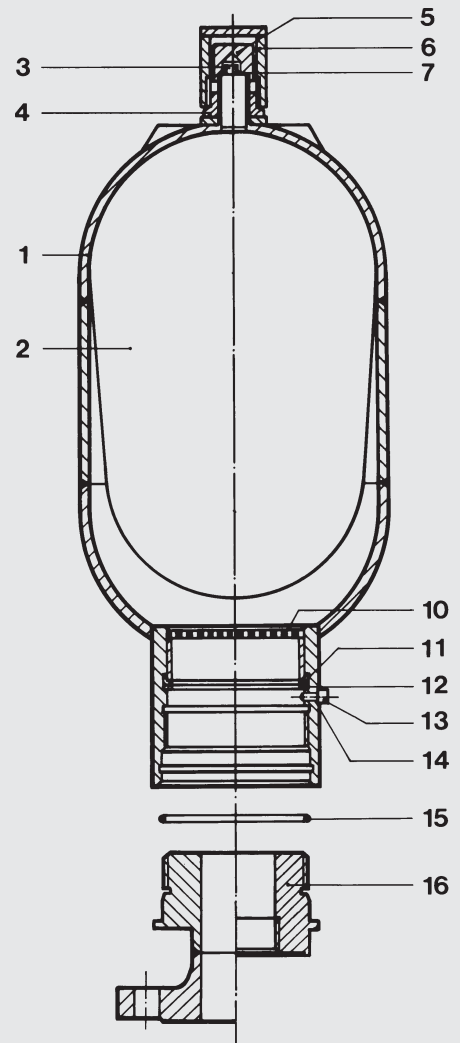

#### SB 40

Perm. working pressure 40 bar (PED 97/23/EC)

Nom. volume litres	eff. gas volume litres	Weight kg	A mm	B mm	C mm
2.5	2.5	9	541	122	68
5	5.0	13	891	106	
10	8.7	14	533	106	
20	18.0	23	843	106	
32	33.5	38	1363	106	
50	48.6	52	1875	106	

Nom. volume litres	D Ø mm	J Thread ISO DIN 13	K <sup>2)</sup> Thread ISO 228	SW <sub>1</sub> mm	Q <sup>1)</sup> l/s
2.5	108	M100 x 2	G 2	36	5
5					
10					
20					
32	219	M100 x 2	G 2	36	5
50					

<sup>1)</sup> Q = flow rate of pressure fluid (at approx. 0.5 bar pressure drop via adaptor)

<sup>2)</sup> Item 16 must be ordered separately

Description	Item
Gas valve insert *	3
Repair kit *	
consisting of:	
Bladder	2
Gas valve insert	3
Lock nut	4
Cap nut	5
Valve protection cap	6
O-ring 7.5 x 2.0	7
Seal ring	14
O-ring 102 x 3	15
Hydraulic connector, complete, consisting of:	
Perforated disc	10
Anti-extrusion ring	11
Retaining ring	12
Vent screw	13
Seal ring	14
O-ring 102 x 3	15
O-ring 102 x 3	15

\* Recommended spare parts  
Item 1 not available as a spare part.

## 3.2. BLADDER ACCUMULATOR SB40 - 70 ... 220

### 3.2.1 Construction

HYDAC low pressure accumulators, type SB 40 - 70 ... 220 consist of:

- A welded pressure vessel which is compact and yet suitable for high flow rates and large volumes. The pressure vessel is manufactured in carbon steel, or in stainless steel.
- An accumulator bladder with gas valve.
- A hydraulic connector with check valve.

### 3.2.2 Dimensions SB40 - 70 ... 220

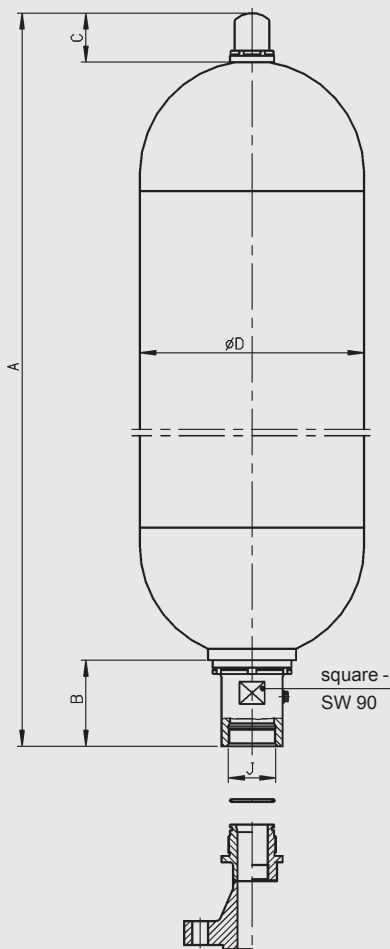

#### SB40 - 70 ... 220

Perm. working pressure 40 bar  
(PED 97/23/EC)

Nom. volume litres	eff. gas volume litres	Weight kg	A max. mm	B mm
70	64	94	1199	137
100	111	113	1629	
130	133	133	1879	
190	192	169	2086	
220	220	193	2330	

Nom. volume litres	C mm	D mm	J Thread ISO 228	Q l/s
70	78	356	G 2 ½	30
100				
130				
190		407		
220				

### 3.2.3 Spare parts SB40 - 70 ... 220

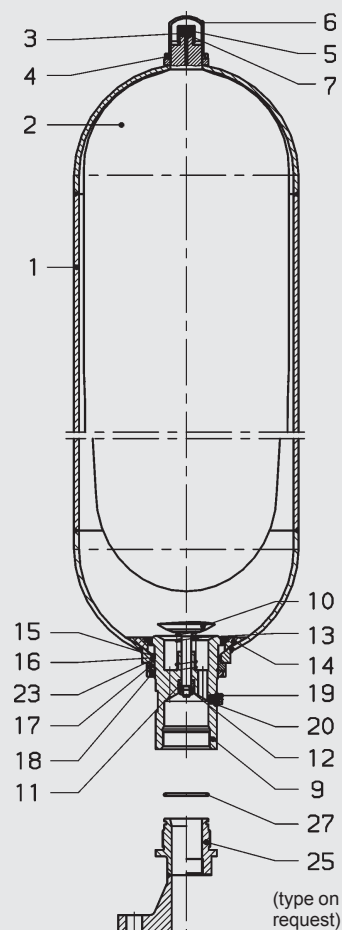

Designation	Item
Anti-extrusion ring	14
Gas valve insert *	3
Repair kit *	
consisting of:	
Bladder	2
Gas valve insert	3
Lock nut	4
Cap nut	5
Valve protection cap	6
O-ring 7.5 x 2.0	7
Protection ring	15
O-ring	16
Seal ring	20
Back-up ring	23
O-ring	27
Oil valve complete, consisting of:	
Oil valve body	9
Valve	10
Damping sleeve	11
Safety nut	12
Valve spring	13
Anti-extrusion ring	14
Protection ring	15
O-ring (see above)	16
Spacer	17
Lock nut	18
Vent screw	19
Seal ring	20
Back-up ring	23
Seal kit *	
consisting of:	
O-ring (see above)	7
Protection ring	15
O-ring (see above)	16
Seal ring	20
Back-up ring	23
O-ring (see above)	27

\* recommended spare parts  
Item 1 not available as a spare part

### 3.3. HIGH FLOW BLADDER ACCUMULATORS SB 35 HB

#### 3.3.1 Construction

HYDAC high flow bladder accumulators, type SB 35 HB, are high performance accumulators for flow rates of up to 70 litres/second.

They consist of a pressure vessel in a weld construction and a flexible bladder with gas valve.

The pressure vessel contains a fixed perforated disc, permitting a high flow rate through its large free cross-section. For use with chemically aggressive fluids, the shell can be manufactured in stainless steel. See point 2.1. for bladder materials.

#### 3.3.2 Dimensions SB35 HB

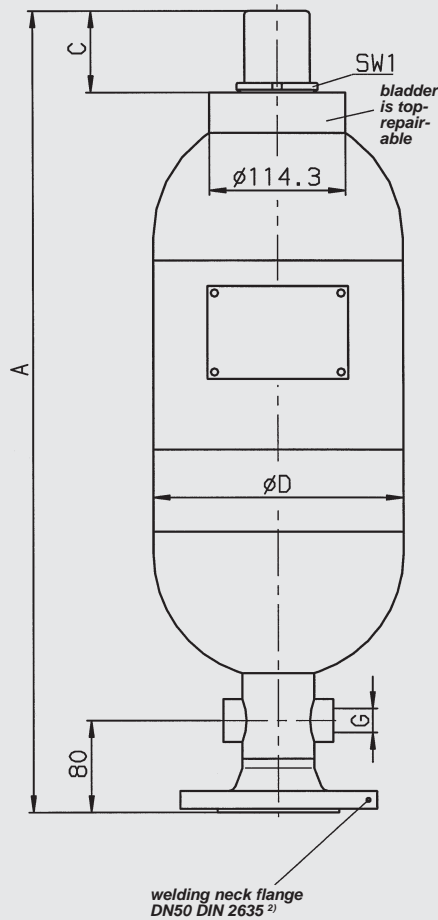

#### 3.3.3 Spare parts SB35 HB

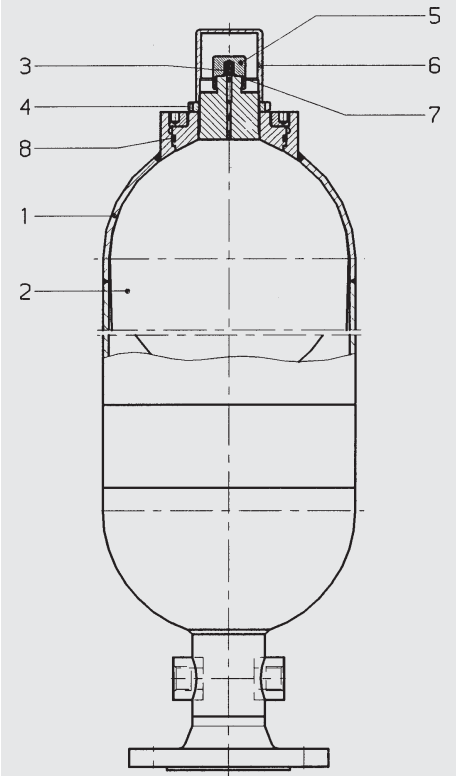

#### SB35 HB

Perm. working pressure 35 bar  
(PED 97/23/EC)

Nom. volume litres	eff. gas volume litres	Weight kg	A max. mm
20	19.8	43	1081
32	35.0	56	1591
50	50.0	69	2091

Nom. volume litres	C mm	ø D mm	G Thread ISO 228	SW <sub>1</sub> mm	Q <sup>3)</sup> l/s
20	63	219	G 1/2	36	70
32				ø 68 <sup>1)</sup>	
50	78				

<sup>1)</sup> Nut

<sup>2)</sup> other sizes on request

<sup>3)</sup> Q = max. flow rate of operating fluid

Description	Item
Gas valve insert *	3
Repair kit * consisting of:	
Bladder	2
Gas valve insert	3
Lock nut	4
Cap nut	5
Valve protection cap	6
O-ring 7.5 x 2.0	7
O-ring 84.5 x 3.0	8

\* recommended spare parts

Item 1 not available as a spare part

### 3.4. LOW PRESSURE ACCUMULATORS SB16/35A AND SB16/35AH

#### 3.4.1 Construction

HYDAC low pressure bladder accumulators for large volumes, type SB 35 A and SB 16 A, are in a weld construction in carbon steel or stainless steel.

The hydraulic outlet is covered by a perforated disc, which prevents the flexible bladder extruding from the shell. The bladder is top-repairable.

The bladder accumulators have a connection assembly suitable for max. 15 l/s (SB 16/35 A) or 70 l/s (SB 16/35 AH) at a max. 2 bar pressure drop.

#### 3.4.2 Dimensions SB16/35A, SB16/35AH

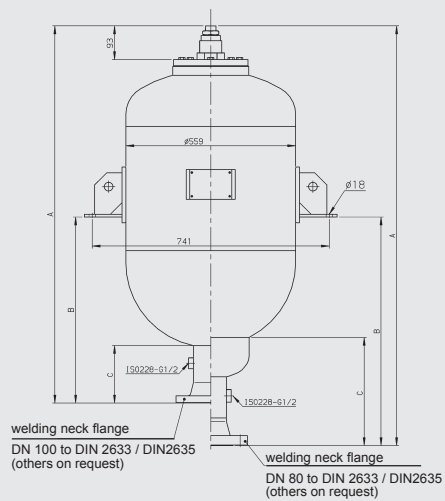

#### 3.4.3 Spare parts SB16/35A, SB16/35AH

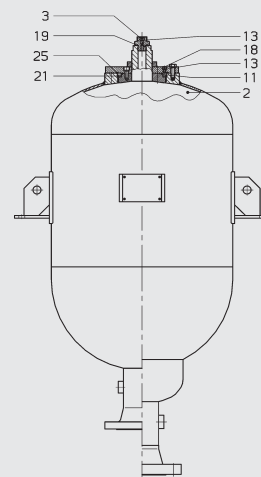

#### SB16/35 A

Perm. working pressure 16/35 bar (PED 97/23/EC)

Nom. volume litres	eff. gas volume litres	Weight kg		A (approx.) mm	
		SB16A	SB35A	SB16A	SB35A
100	99	84	144	870	880
150	143	101	161	1070	1080
200	187	122	223	1310	1320
300	278	155	288	1710	1720
375	392	191	326	2230	2240
450	480	237	386	2625	2635

Nom. volume litres	B (approx.) mm		C (approx.) mm		DN* DIN 2633
	SB16A	SB35A	SB16A	SB35A	
100	390	403	185	198	100
150	490	503			
200	685	698			
300	975	988			
375	1250	1263			
450	1465	1478			

#### SB16/35 AH

Perm. working pressure 16/35 bar (PED 97/23/EC)

Nom. volume litres	eff. gas volume litres	Weight kg		A (approx.) mm	
		SB16AH	SB35AH	SB16AH	SB35AH
100	99	93	153	957	965
150	143	110	170	1157	1165
200	187	131	230	1417	1425
300	278	164	297	1865	1873
375	392	200	335	2307	2315
450	480	246	395	2702	2710

Nom. volume litres	B (approx.) mm		C (approx.) mm		DN* DIN 2635 / 2633
	SB16AH	SB35AH	SB16AH	SB35AH	
100	457	465	245	254	80
150	557	565			
200	842	850			
300	1092	1100			
375	1342	1350			
450	1542	1550			

\* other sizes on request

Designation	Item
Accumulator bladder	2
Blanking plug	3
Seal ring	13
O-ring	11
Vent screw	18
O-ring	19
O-ring	25
Retaining ring	21

## 4. NOTE

The information in this brochure relates to the operating conditions and applications described.

For applications or operating conditions not described, please contact the relevant technical department.

Subject to technical modifications.