

## Pressure Relief Valves DB10

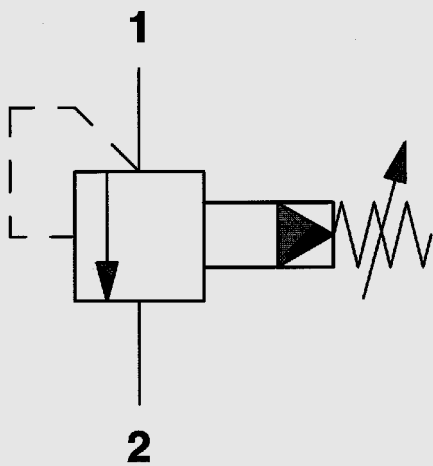

up to 350 bar  
up to 100 l/min

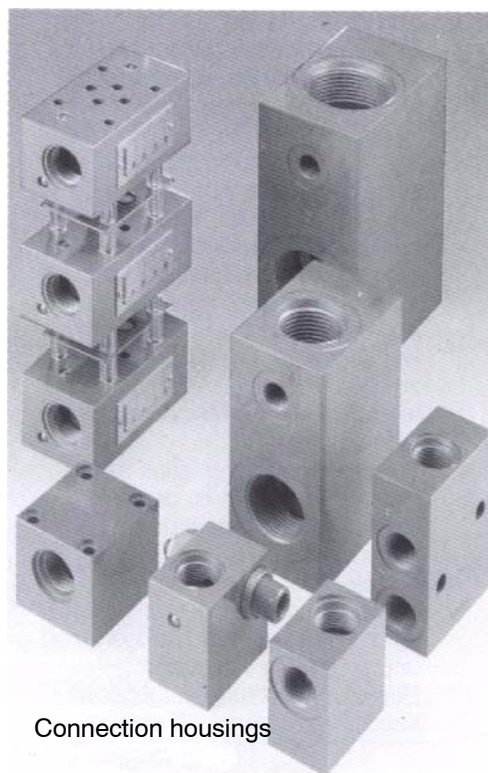

# 1. DESCRIPTION

## 1.1. GENERAL

According to DIN-ISO 1219, HYDAC pressure relief valves DB10120A are valves for oil hydraulic systems to control pressure by opening the outlet when the inlet pressure exceeds the spring force. The DB10120A is a pilot-operated pressure relief valve which means that, in relation to its size, a high flow rate can be achieved with excellent constant pressure characteristics. Further advantages of these valves are:

- standardised installation dimensions mean that they are flexible and suited to many different applications
- their compact design allows space-saving installation in connection housings, control blocks, etc. especially where installation space is limited
- low hysteresis and high stability ensure accurate pressure control
- optimum system adaptation by means of various pressure ranges
- simple assembly due to service-friendly cartridge valve technology
- a wide range of connection housings is available for inline and sandwich mounting
- built-in contamination strainer ensures correct operation
- the standard surface protection is suitable for use in mobile applications

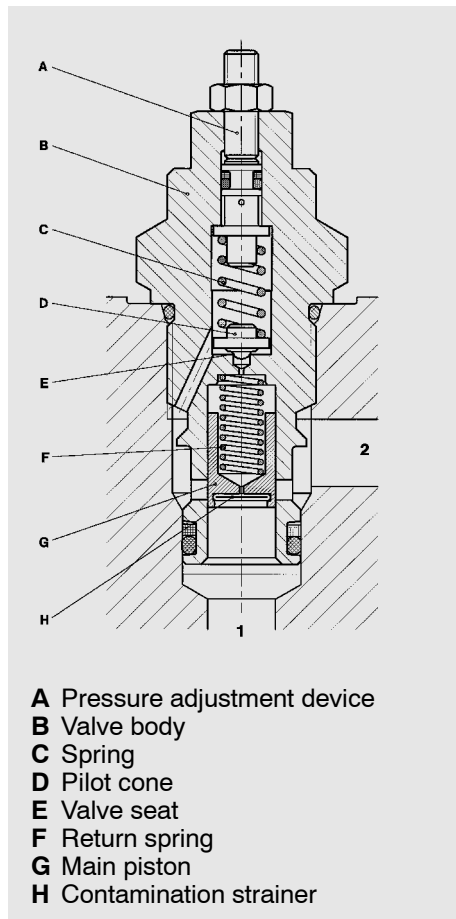

## 1.2. FUNCTION

HYDAC pressure relief valves DB10120A are pilot-operated valves for oil hydraulic systems due to the spring-loaded cone seat valves. The main stage basically consists of the hardened and ground main piston and the valve body. The main piston located in the valve body is pushed down by the return spring. The pilot stage consists of the valve seat which is built into the valve body, a hardened and ground pilot cone and the adjustment device for setting the initial spring tension. This spring force pushes the pilot cone onto the valve seat. The system pressure acts on the underside of the pilot cone via port 1 of the valve. If the hydraulic pressure on the pilot cone is below the initial force of the spring, the valve is closed. If the hydraulic pressure exceeds the pre-set spring force, the pilot cone is lifted off the valve seat and the oil flows from behind the main piston to tank port 2. The resulting pressure differential causes the main piston to move upwards against the return spring and allows oil to flow from port 1 to port 2. This relieves the pressure across port 1.

## 1.3. APPLICATION

HYDAC pressure relief valves DB10120A are used:

- as safety valves for limiting pressure to the maximum permissible
- as safety valves for pumps
- for limiting pressure in hydraulic units and control blocks

Areas of application could be, for example:

- hydraulic units
- elevating platforms
- lifts
- mobile hydraulics
- force or torque limiting on drive elements

## 1.4. NOTE

- During commissioning carry out venting by switching the pump on and off several times when the valve is released of pressure
- When fitting the valves into control blocks and housings the recommended torque ratings must be observed! (see point 3)
- Please take connection layout and direction of flow into account. There must be no flow from 2 to 1 (shock valve)
- max. pressure across tank port 2: 100 bar
- Due to its spool valve construction the valve is not suitable for leakage-free sealing of an appliance
- Important: The cracking pressure of the valve increases by the amount of pressure across tank port 2!

### Important:

If the connections are incorrect or the pressure has been incorrectly set above the operating pressure, the safety function of the valve is no longer operational.

## 2. TECHNICAL SPECIFICATIONS

### 2.1. GENERAL

#### 2.1.1. Designation and symbol

Pressure relief valve

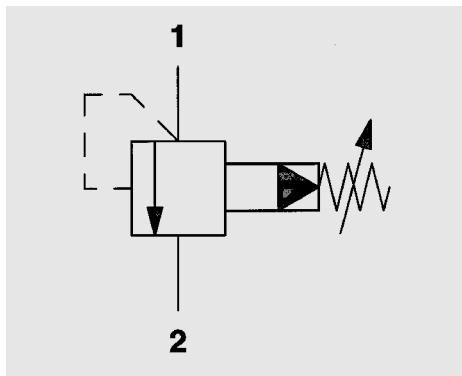

2.1.2. **Model code**  
(also order example)

**DB 10120A - 02 X - 350 V**

**Pressure relief valve**

**Installation dimensions**

10120A = 2-way installation dimensions  
(see point 3)

**Type**

02 = standard model, zinc-plated

**Series**

(determined by manufacturer)

**Setting pressure range**

(see also 2.2.7.)

100 = up to 100 bar

250 = up to 250 bar

350 = up to 350 bar

**Type of adjustment**

V = adjustable

#### Standard models

Stock no. (= order no.)	Model code
561040	DB10120A-02X-100V
561041	DB10120A-02X-250V
561076	DB10120A-02X-350V

Please quote stock no. when ordering.

#### 2.1.3. Type of construction

Piston valve, pilot-operated by cone seat valve

#### 2.1.4. Type of mounting

Cartridge valve

#### 2.1.5. Mounting position

Optional

#### 2.1.6. Weight

DB10120A...0.13 kg

#### 2.1.7. Direction of flow

From 1 to 2 pressure relief function

#### 2.1.8. Ambient temperature range

min. - 20 5C

max. + 80 5C

#### 2.1.9. Materials

Valve body: high tensile steel  
Closing elements: hardened and ground steel, wear-resistant  
Seals: compatible with hydraulic oil to DIN 51524 Part 1 and 2

#### 2.1.10. Type of connection

Suitable connection housings with installation dimensions 10120A are available.  
See separate housing brochure no. E 5.252../..

## 2.2. HYDRAULIC DETAILS

### 2.2.1. Nominal pressure

Inlet (port 1): up to 350 bar

Outlet (port 2): up to 100 bar

### 2.2.2. Operating pressure ranges

up to 100 bar

up to 250 bar

up to 350 bar

for lowest setting pressures see point 2.2.7.

Pressure, dependent on flow rate

### 2.2.3. Operating fluid

Mineral oil to DIN 51524

Part 1 and 2

### 2.2.4. Operating fluid temperature range

min. - 20 5C

max. + 80 5C

### 2.2.5. Viscosity range

min 10 mm<sup>2</sup>/s

max 380 mm<sup>2</sup>/s

### 2.2.6. Filtration

Max. permissible contamination level of the operating fluid to ISO 4406 Class 21/19/16 (NAS1638, Class 10).

We therefore recommend a filter with a minimum retention rate of  $\beta_{20} \geq 100$ .

The fitting of filters and regular replacement of elements guarantees correct functioning, reduces wear and tear and increases the service life.

## 2.2.7. Pressure, dependent on flow rate

(measured at  $n = 36 \text{ mm}^2/\text{s}$  and at  $t_{\text{oil}} = 50 \text{ 5C}$ )

350 V

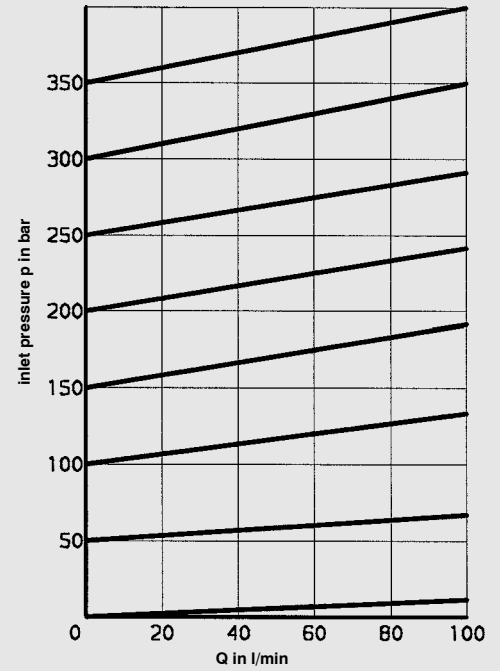

250 V

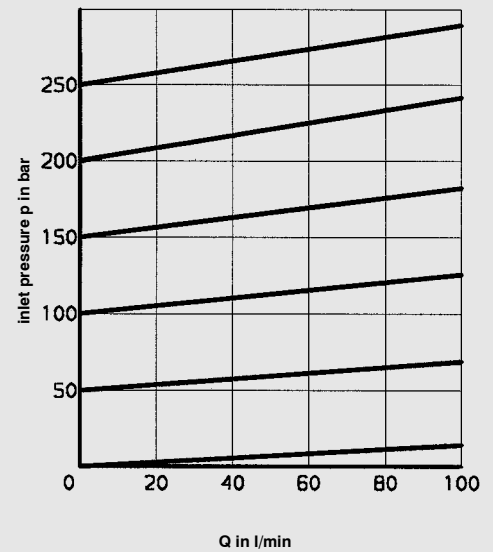

100 V

