

HYDAC

INTERNATIONAL

Return Line Filter RFM

Flow rates up to 850 l/min

Pressure range up to 10 bar

Material:

Aluminium/Steel/Synthetic material

Return line filters type RFM are designed to be mounted on tank tops to filter out contamination.

Their light and compact design makes them particularly suited to mobile applications.

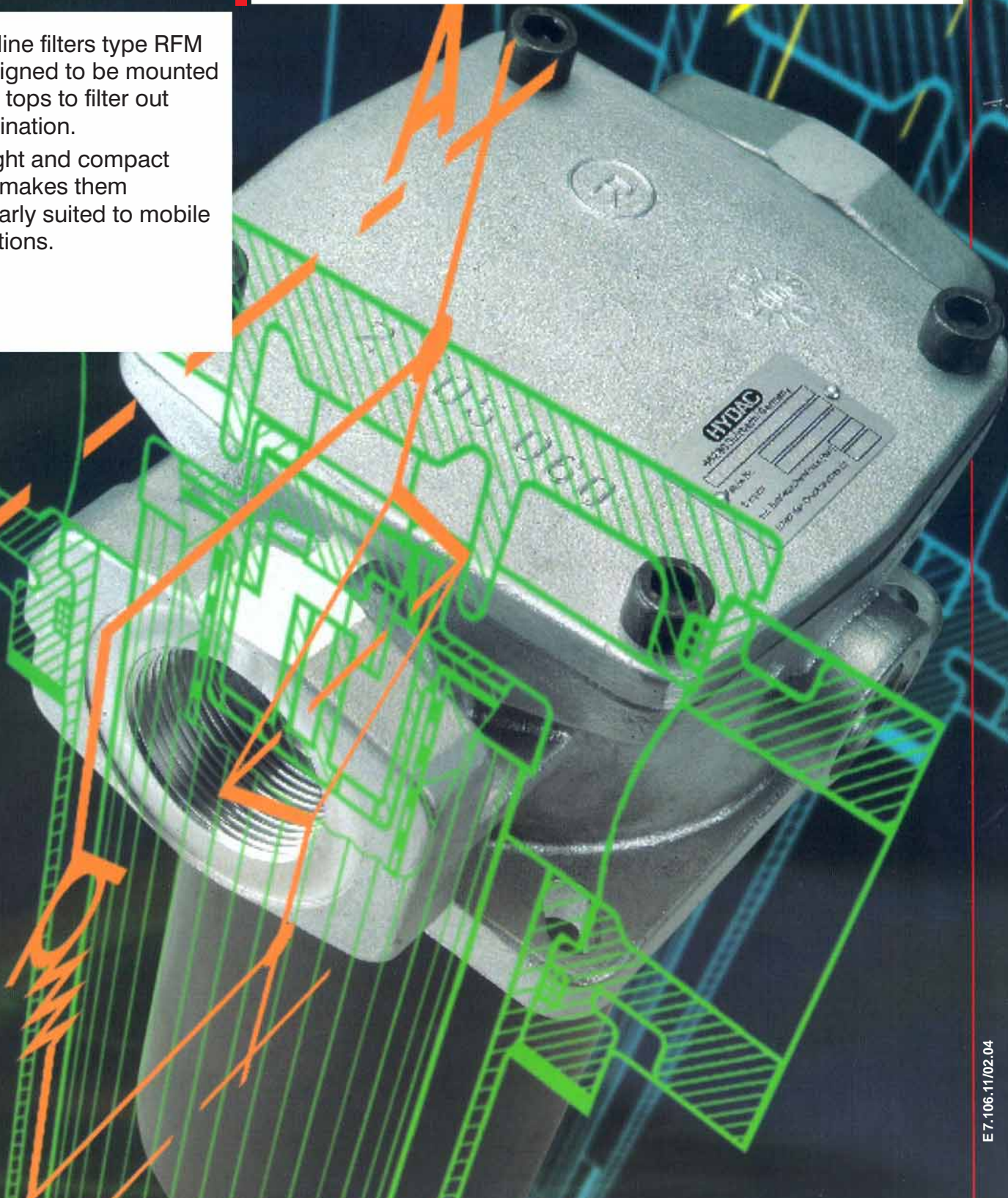

1. TECHNICAL SPECIFICATIONS

1.1. FILTER HOUSING

Construction

The return line filter consists of a separate filter head with a suspended filter bowl and bolt-on cover plate.

Connections for clogging indicators are standard. (Exceptions: sizes 75, 90, 150, 165, 185, 210 and 270 are available with or without indicator connection)

1.2. FILTER ELEMENTS

Original Hydac filter elements guarantee reliable function and protect hydraulic components and systems which are sensitive to contamination from wear and tear. Performance and quality tests according to international standards guarantee reliable operation of the filter.

HYDAC filters are validated and their quality is continuously monitored according to the following standards:

- DIN ISO 2941: Verification of collapse / burst resistance
- DIN ISO 2942: Verification of fabrication integrity and determination of first bubble point
- DIN ISO 2943: Verification of material compatibility with fluid
- ISO 3724: Verification of flow fatigue characteristics
- ISO 3968: Evaluation of pressure drop versus flow characteristics
- ISO 16889: Multi-pass method for evaluating filtration performance

In addition to guaranteeing retention and flow rate characteristics, the filter elements have excellent structural stability.

The careful construction and mechanically stable support of the filter media guarantee above-average beta value stability and flow fatigue characteristics of the filter elements.

The filter elements are available with the following collapse/burst stability values:

Betamicon® (BN3HC):	25 bar
Paper (P/HC):	10 bar
Wire mesh (W/HC):	30 bar
Betamicon®/Aquamicron® (BN/AM):	10 bar
Aquamicron® (AM):	10 bar

For further information on filter elements:

Brochure no.: 7.200../..

1.3. CLOGGING INDICATOR

(Example)

Type of indicator _____
VMF, VR return line indicator

Pressure setting _____
2 2 bar

Indicator type code _____
B. visual
C. electrical
D. visual/electrical

Modification number _____
X the latest version is always supplied

Supplementary details _____
V Viton

VR 2 C.X /-V

For further details on clogging indicators, please see brochure no.: **7.050../..**

1.4. SEALS

Choice of Perbunan (= NBR) or Viton (= FPM for HFD fluids).

1.5. SPECIAL MODELS AND ACCESSORIES

- Connections for filling the hydraulic system via the return line filter element (size 330 and over)
- Threaded connection in the outlet
- Tank breather filter in the head, built-in on sizes 75 to 185
- Dipstick for sizes 75, 165, 185 (sizes 90 and 150 on request)

1.6. SPARE PARTS

See Original Spare Parts List and Maintenance Instructions.

1.7. COMPATIBILITY WITH OPERATING FLUIDS

- DIN ISO 2943:
- Hydraulic oils H to HLPD to DIN 51524
 - Lubrication oils to DIN 51517, APJ, ACEA, DIN 51515, ISO 6743
 - Compressor oils to DIN 51506
 - Rapidly biodegradable operating fluids to VDMA 24568 HETG, HEES, HEPG
 - Non-flam operating fluids HFC and HFD
 - Operating fluids with high water content (>50 % water content) on request

For further details on filter elements:

Brochure no.: E 7.200../..

1.8. WARNING NOTES

- If a pipe extension has been fitted to the outlet of the two-piece filter housing, the pipe must be made of synthetic material or thin-wall aluminium.
- Extensions must be protected by fitting a bulkhead or other means of protection so that no forces can be transmitted to the filter housing or the extension.
- The filter can normally only be used for tank-mounting.

- The filter must be fitted absolutely vertically, or, after consultation with the manufacturer, only within the tolerances specified.

- The filter must not be used as a suction filter.

- Components (e.g. coolers) must not be fitted after the filter.

2. GENERAL

Mounting

Tank-top filter

Temperature range

-30 °C ... +100 °C
(short-term -40 °C)

Pressure setting of the return line clogging indicator

$\Delta p_a = 2 \text{ bar} -0.2 \text{ bar}$
(compared with atmospheric pressure)
Other pressure settings on request.

Cracking pressure of bypass valve

$\Delta p_o = 3 \text{ bar} +0.5 \text{ bar}$
Other pressure settings on request.

Hydraulic symbol

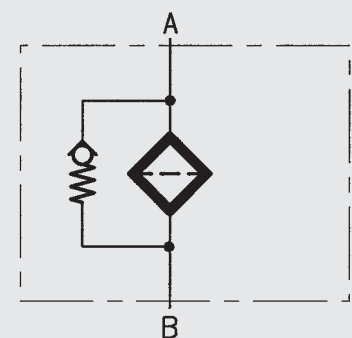

3. MODEL CODE

(also order example)

RFM BN/HC 500 B F F 10 D 1 . X /-L24

3.1. COMPLETE FILTER

Filter type

Filter material of element

- BN/HC Betamicon® (BN3HC)
- P/HC paper
- W/HC stainless steel wire mesh
- BN/AM Betamicon®/Aquamicron® (size 330 and over)
- AM Aquamicron® (size 330 and over)

Material of housing / Size

A/St/PA 75, 90, 150, 165, 185, 210, 270, 330, 500, 661, 851

Operating pressure

B = 10 bar

Additional second inlet

Type	connection	filter size			
		330	500	661	851
F	G 1 1/2	●	●		
K	SAE DN 40	●	●		
M	SAE DN 65			●	●

Type of connection / Size (1 inlet)

Type	connection	filter size										
		75	90	150	165	185	210	270	330	500	661	851
B	G 1/2	●			●	●						
C	G 3/4	●	●	●	●	●						
D	G 1	●			●	●	●	●				
E	G 1 1/4						●	●				
F	G 1 1/2						●	●	●	●		
K	SAE DN 40								●	●		
M	SAE DN 65										●	●
Z	according to customer specification											

other connections on request

- KIT in-tank mounting kit (all sizes)
 - SET in-tank mounting set (only on RFM 330 and 500)
 - S in-tank welding set (only on RFM 75, 165, 185, 330, 500)
- } see point 3.1.2 ²⁾

Filtration rating in µm

- BN3HC : 3, 5, 10, 20
- P/HC : 10, 20
- W/HC : 25, 50, 100, 200
- BN/AM : 3, 10 (size 330 and over)
- AM : 40 (size 330 and over)

Type of clogging indicator

- Y with plastic blanking plug
- W¹⁾ without port for clogging indicator
- A without clogging indicator, steel blanking plug in indicator port
- B with visual indicator (for sizes 330-851)
- C with electrical indicator
- D with combined visual/electrical indicator
- E/ES with pressure gauge
- F with pressure switch (only up to 42 V)

for other clogging indicators
see brochure no. E 7.050../..

Type code

- 0 no indicator port, no indicator
- 1-x see point 3.1.1

Modification number

- X the latest version is always supplied

Supplementary details

- V FPM seals, filter suitable for rapidly biodegradable oils and phosphate esters (HFD-R)
- A...B.. corresponding pressure setting of the clogging indicator and corresp. cracking pressure of the bypass valve in bar (e.g. A5-B6)
- L... light with corresponding voltage (24V, 48V, 110V, 220V)
- LED 2 light-emitting diodes up to 24 volt
- BA filling connection (for size 330 and over)
- G threaded connection in the outlet (size 330 and over)
- T with tank breather filter (only sizes 75, 90, 150, 165 and 185)
- Vxxx with pipe extension (where xxx is the final dimension of the extension)
- DFxxx spring for RFM...KIT (where xxx is the corresponding length)
- PSxx dipstick for sizes 75, 165, 185 on request
- PZxx dipstick for sizes 90, 150 on request

¹⁾ for sizes 75, 90, 150, 165, 185, 210 and 270
²⁾ further tank mounting solutions on request

3.1.1 Type code

RFM 90/150

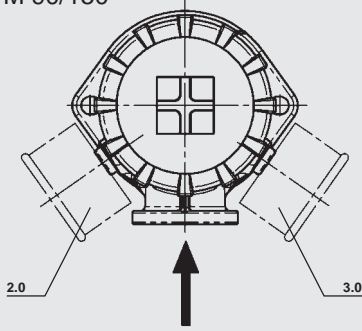

RFM 75/165/185

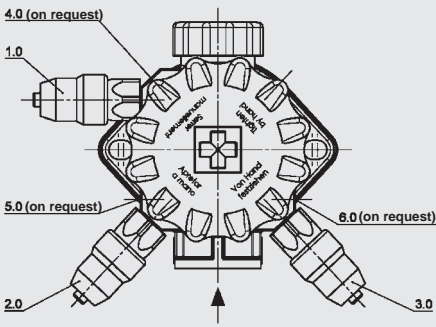

RFM 210/270

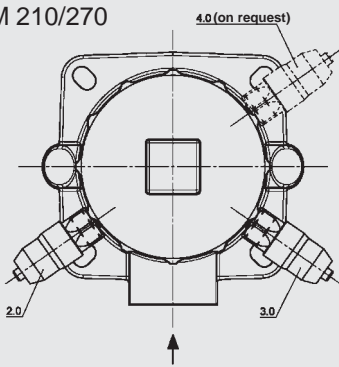

RFM 330/500

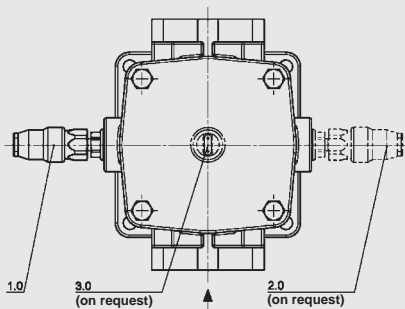

RFM 661/851

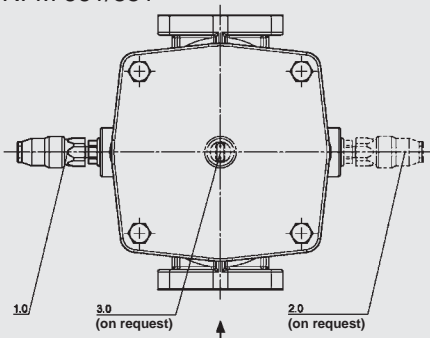

Type code	Mounting position of the clogging indicator	Type of clogging indicator
2.X	Clogging indicator front left, 45° to inlet	VMF...
3.X	Clogging indicator front right, 45° to inlet	VMF...

Type code	Mounting position of the clogging indicator	Type of clogging indicator
1.X	Clogging indicator back left, 90° to inlet	VMF...
2.X	Clogging indicator front left 45° to inlet	VMF...
3.X	Clogging indicator front right 45° to inlet	VMF...

Type code	Mounting position of the clogging indicator	Type of clogging indicator
2.X	Clogging indicator front left, 45° to inlet	VMF...
3.X	Clogging indicator front right, 45° to inlet	VMF...

Type code	Mounting position of the clogging indicator	Type of clogging indicator
1.X	Clogging indicator on left hand side, 90° to inlet	VR...

Type code	Mounting position of the clogging indicator	Type of clogging indicator
1.X	Clogging indicator on left hand side, 90° to inlet	VR...

Note:
Other type codes on request

3.1.2 In-tank mounting

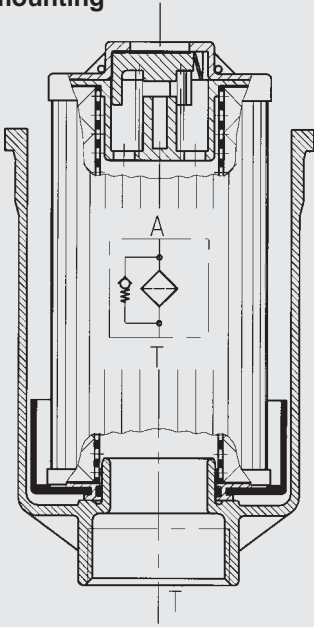

RFM BN/HC 165 **KIT** 10 W 1.0

Type of connection —
In-tank mounting kit (all sizes)
– bowl with element and O-ring

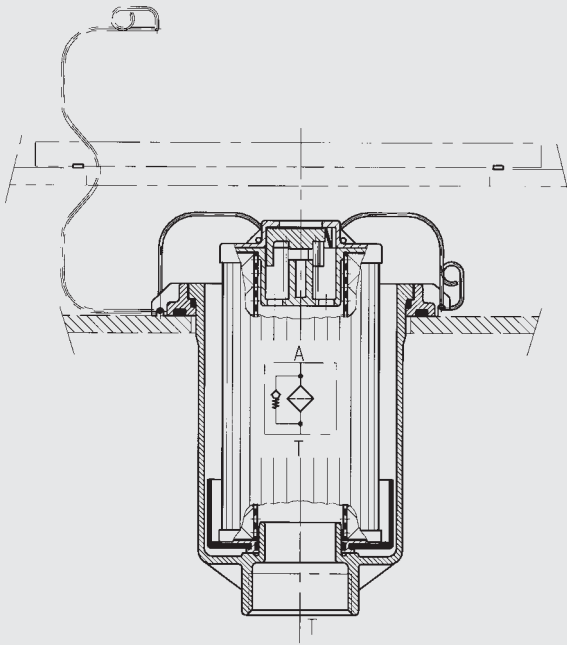

RFM BN/HC 330 **SET** 10 W 1.0

Type of connection —
In-tank mounting set (only on RFM 330 and 500)
– bowl with element and O-ring, plus adaptor ring

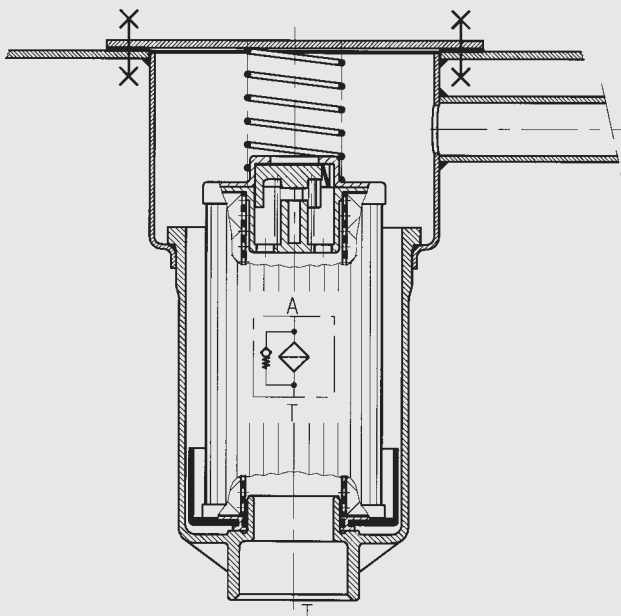

RFM BN/HC 75 **S** 10 W 1.0

Type of connection —
In-tank welding set (only on RFM 75, 165, 185, 330, 500)
– bowl with element and O-ring, plus steel housing

3.2. REPLACEMENT ELEMENT

0500 R 010 BN3HC /-KB

Size _____
0075, 0090, 0150, 0165, 0185, 0210,
0270, 0330, 0500, 0660, 0850

Type _____
R

Filtration rating in μm _____
BN3HC: 3, 5, 10, 20
P/HC: 10, 20
W/HC: 25, 50, 100, 200
BN/AM: 3, 10
AM: 40

Filter material _____
BN3HC, P/HC, W/HC, BN/AM, AM

Supplementary details _____
V FPM seals, filter suitable for rapidly biodegradable oils and phosphate ester (HFD-R)
W NBR seals, filter suitable for oil-water emulsions (HFA, HFC) (only for W/HC elements)
B6 with bypass valve (cracking pressure 6 bar)
KB without bypass valve

4. FILTER SPECIFICATIONS

Filter type	Connection	Element size	Weight [kg] incl. element
75	G $\frac{1}{2}$	0075 R...	0.90
	G $\frac{3}{4}$		
	G1		
90	G $\frac{3}{4}$	0090 R ...	0.54
	G $\frac{1}{2}$		
150	G $\frac{3}{4}$	0150 R ...	0.75
	G $\frac{1}{2}$		
	G1		
165	G $\frac{1}{2}$	0165 R...	1.10
	G $\frac{3}{4}$		
	G1		
185	G $\frac{1}{2}$	0185 R...	1.14
	G $\frac{3}{4}$		
	G1		
210	G1	0210 R...	3.10
	G1 $\frac{1}{4}$		
	G1 $\frac{1}{2}$		
270	G1	0270 R...	4.30
	G1 $\frac{1}{4}$		
	G1 $\frac{1}{2}$		
330	G1 $\frac{1}{2}$	0330 R...	3.90
	SAE DN 40		
500	G1 $\frac{1}{2}$	0500 R...	4.50
	SAE DN 40		
661	SAE DN 65	0660 R...	9.00
851	SAE DN 65	0850 R...	10.50

5. FILTER CALCULATION / SIZING

The total pressure drop of a filter at a certain flow rate is the sum of the housing Δp and the element Δp .

The pressure drop can either be determined with the aid of our Filter Sizing Program, or by using the following graphs.

5.1. ΔP -Q HOUSING GRAPHS TO ISO 3968

The housing graphs apply to mineral oil with a density of 0.86 kg/dm^3 and a kinematic viscosity of $30 \text{ mm}^2/\text{s}$ for the largest nominal width per size in each case.

For turbulent flows the differential pressure changes proportionally to the density. For laminar flows it changes proportionally to the density and the viscosity.

RFM 90/150

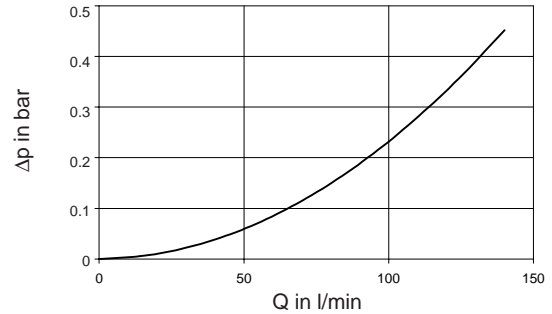

RFM 75/165/185

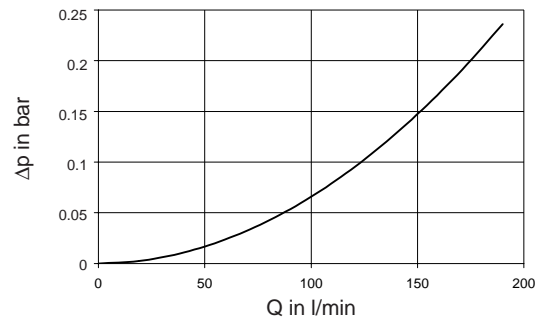

RFM 210/270

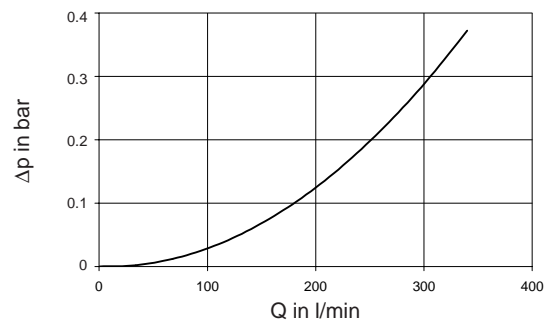

RFM 330/500

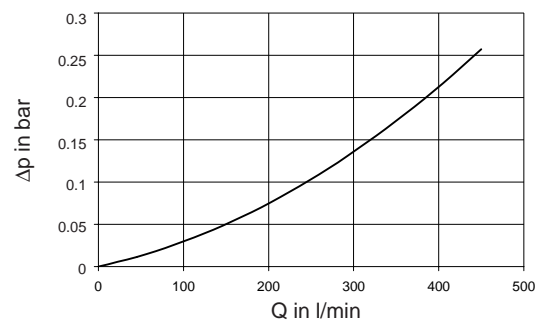

RFM 661/851

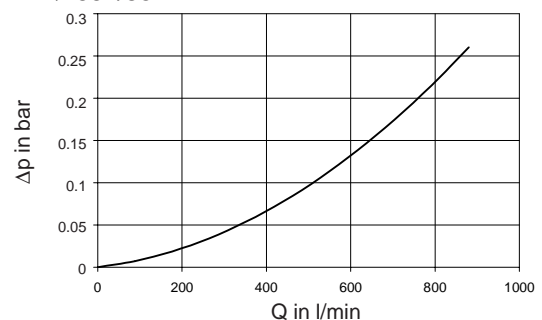

5.2. ΔP -Q GRAPHS - FILTER ELEMENTS

The element graphs apply to mineral oil with a kinematic viscosity of 30 mm²/s.

The pressure drop changes proportionally to the change in viscosity (see Example 5.3.).

BN3HC: Size 75

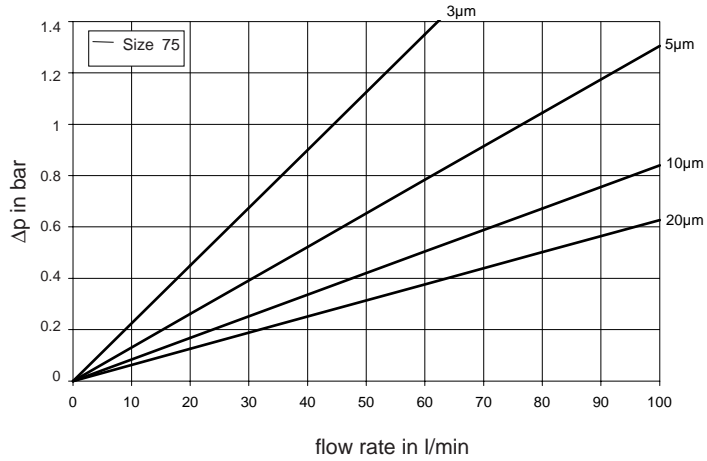

BN3HC: Size 90, 150

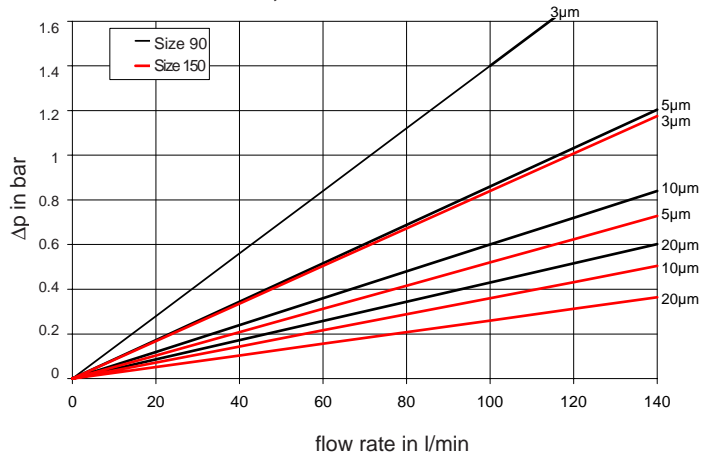

BN3HC: Size 165, 185

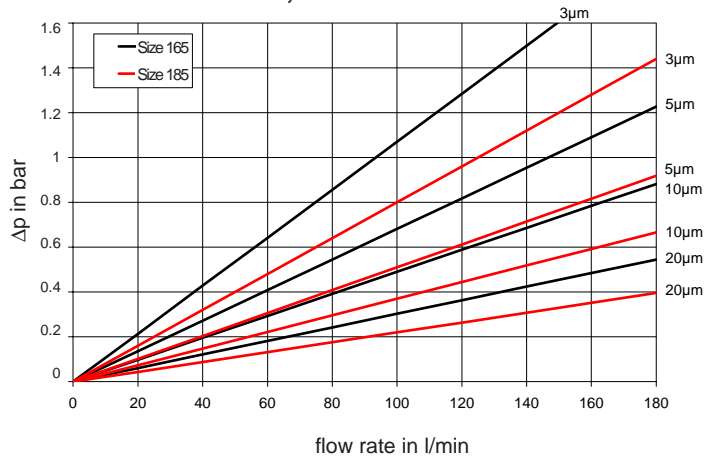

BN3HC: Size 210, 270

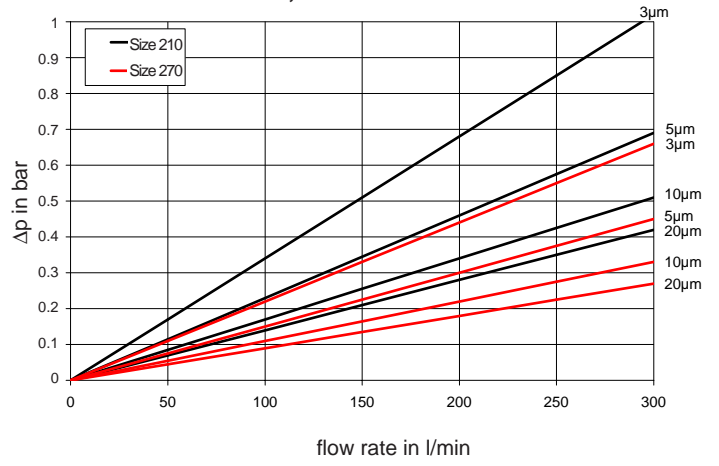

BN3HC: Size 330, 500

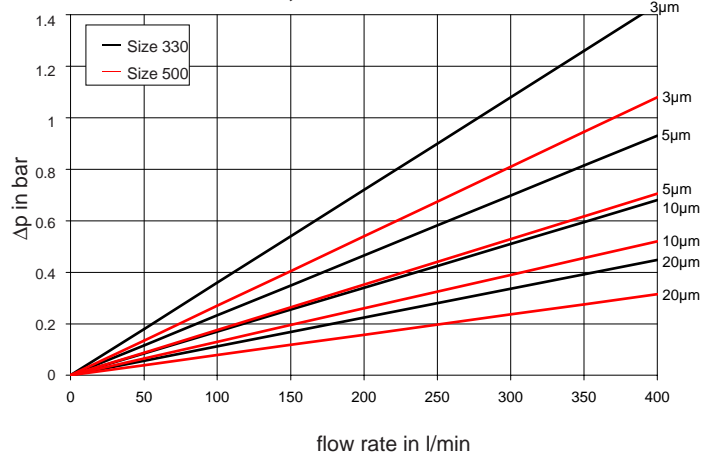

BN3HC: Size 660, 850

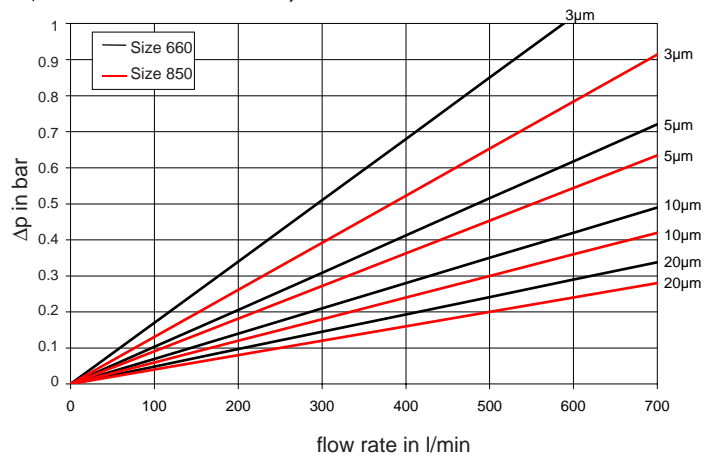

W/HC: Size 75-270

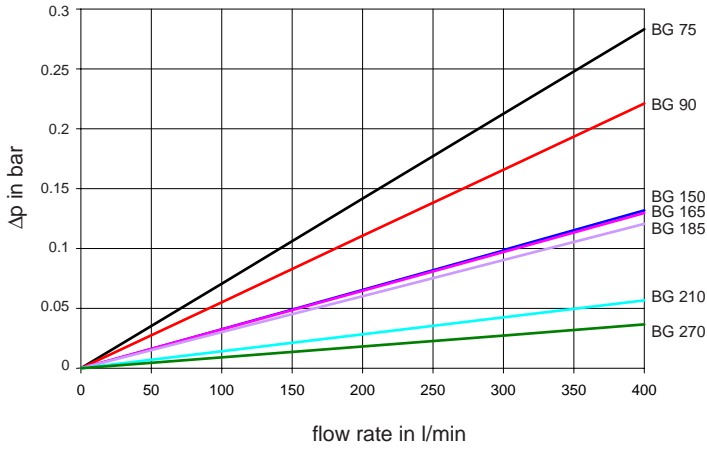

W/HC: Size 330-850

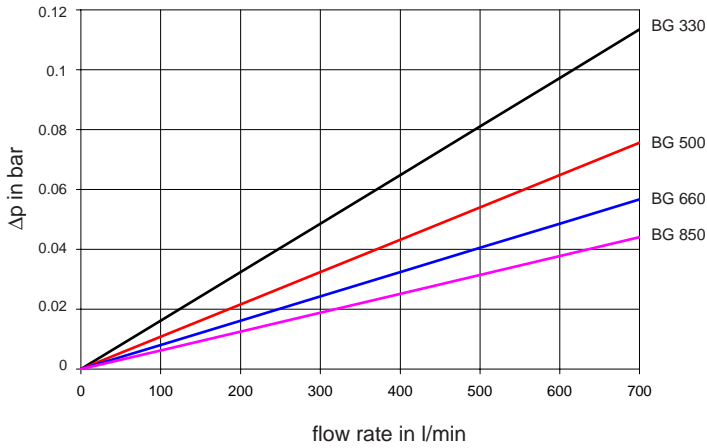

P/HC - 10 μm

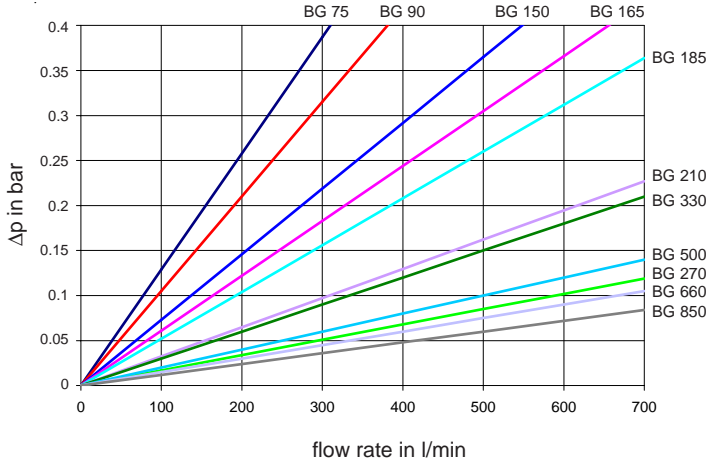

P/HC - 20 μm

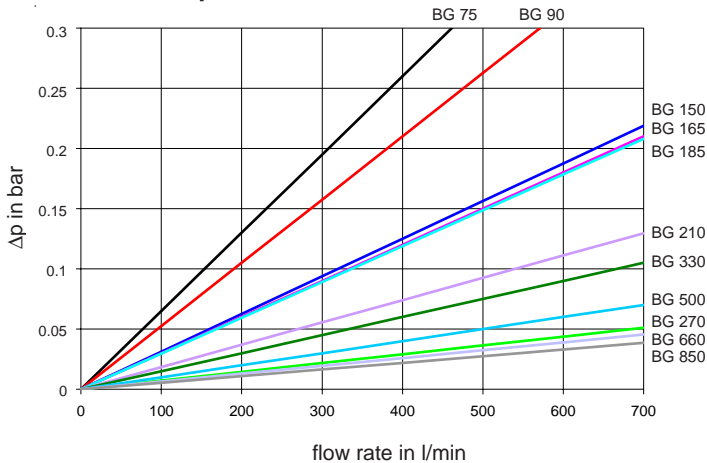

BG = Size

5.3. EXAMPLE

General

$$\Delta p_{\text{total}} = \Delta p_{\text{housing}} + \Delta p_{\text{element}} \cdot \frac{\text{viscosity (mm}^2\text{/s)}}{30 \text{ mm}^2\text{/s}}$$

$\Delta p_{\text{housing}}$ = to be determined from point 5.1.

$\Delta p_{\text{element}}$ = element pressure drop at flow rate Q and viscosity 30 mm²/s according to point 5.2.

Example

System data: RFM 165 with BN3HC element (10 μm);
viscosity = 46 mm²/s (ISO VG 46 at 40 °C);
Q = 50 l/min;

⇒ $\Delta p_{\text{housing}} = 0.02 \text{ bar (at Q)}$

$\Delta p_{\text{element}} = 0.19$

$$\Delta p_{\text{total}} = 0.02 \text{ bar} + 0.19 \cdot \frac{46 \text{ mm}^2\text{/s}}{30 \text{ mm}^2\text{/s}}$$

$$= \underline{\underline{0.31 \text{ bar}}}$$

For ease of calculation, our Filter Sizing Program is available and can be ordered via our website www.hydac.com.

6. DIMENSIONS

6.1. RFM 90, 150

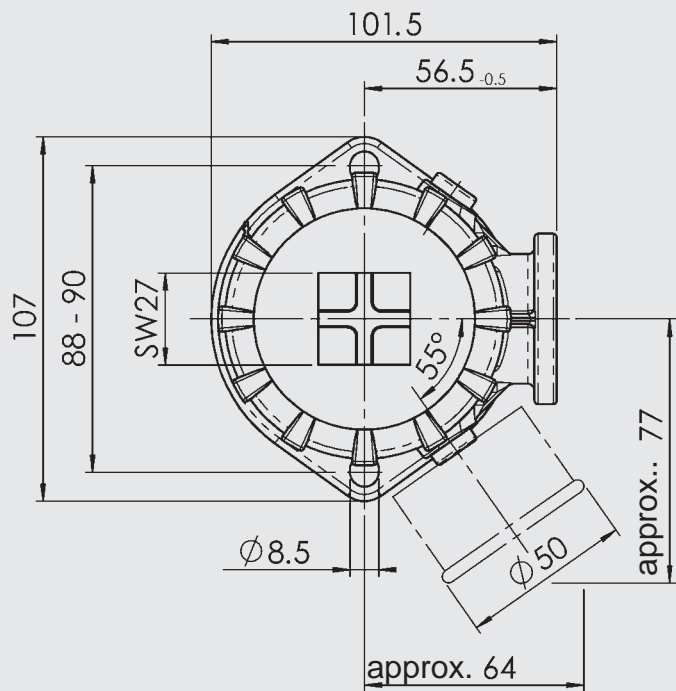
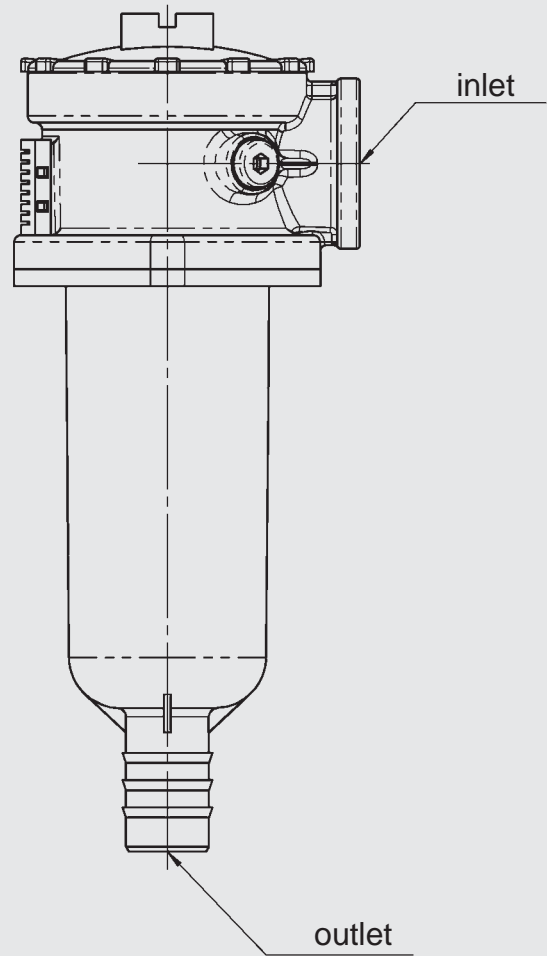
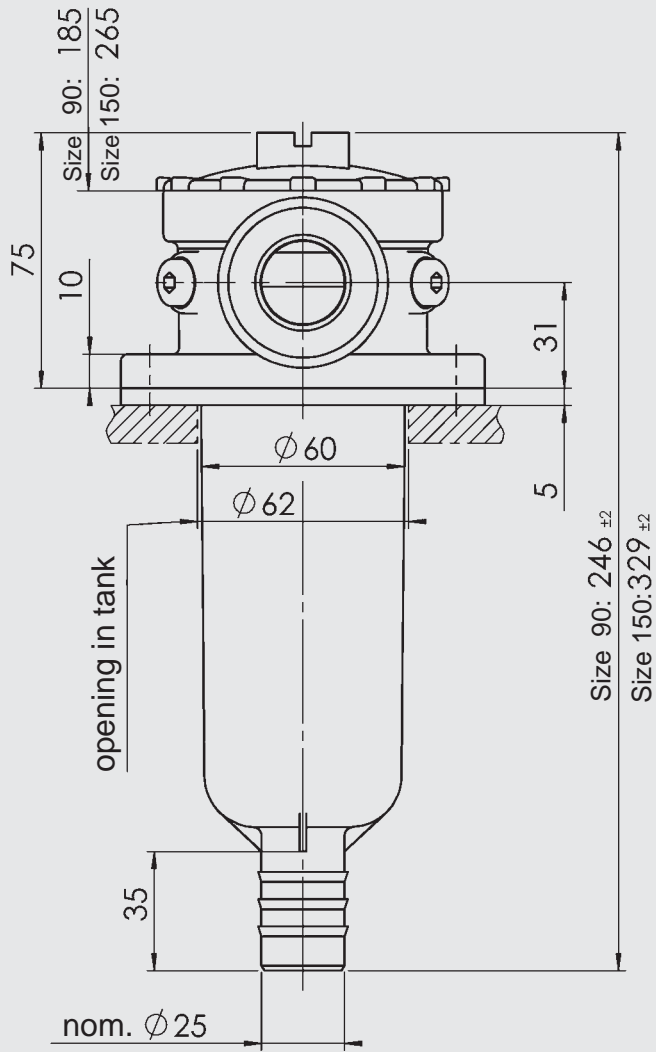

6.2. RFM 75, 165, 185

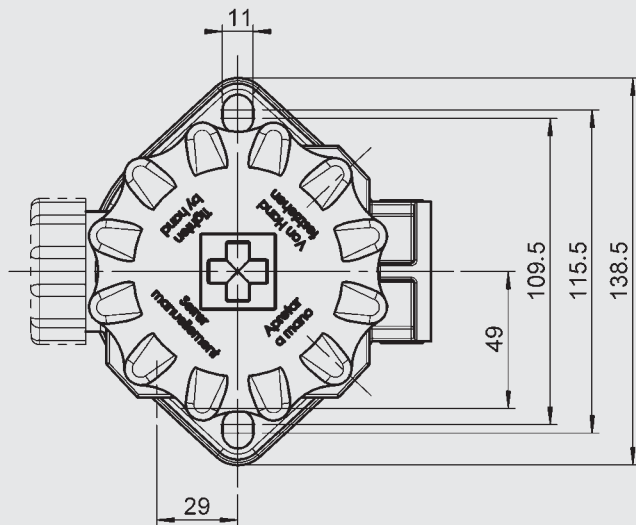
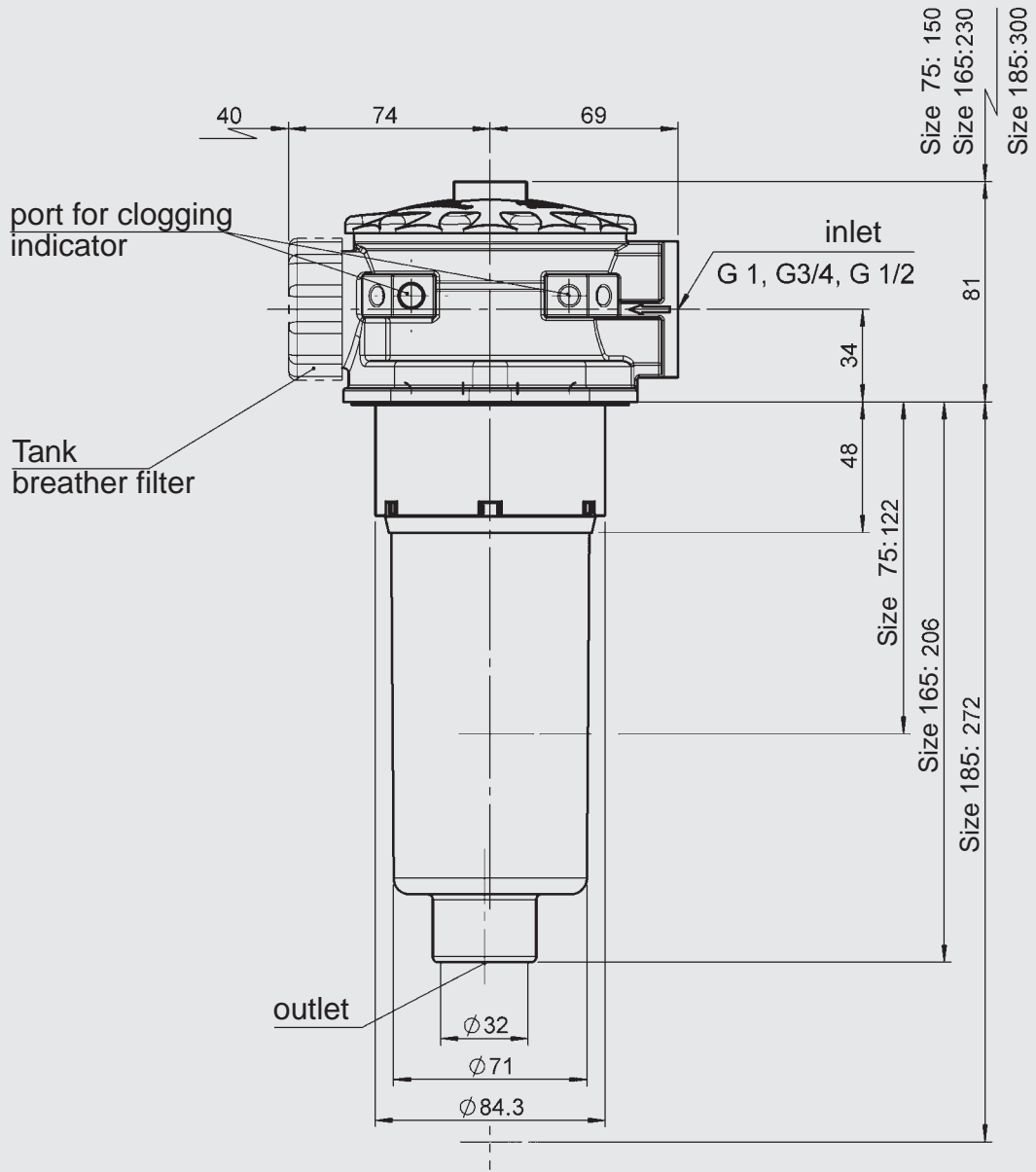

6.3. RFM 210, 270

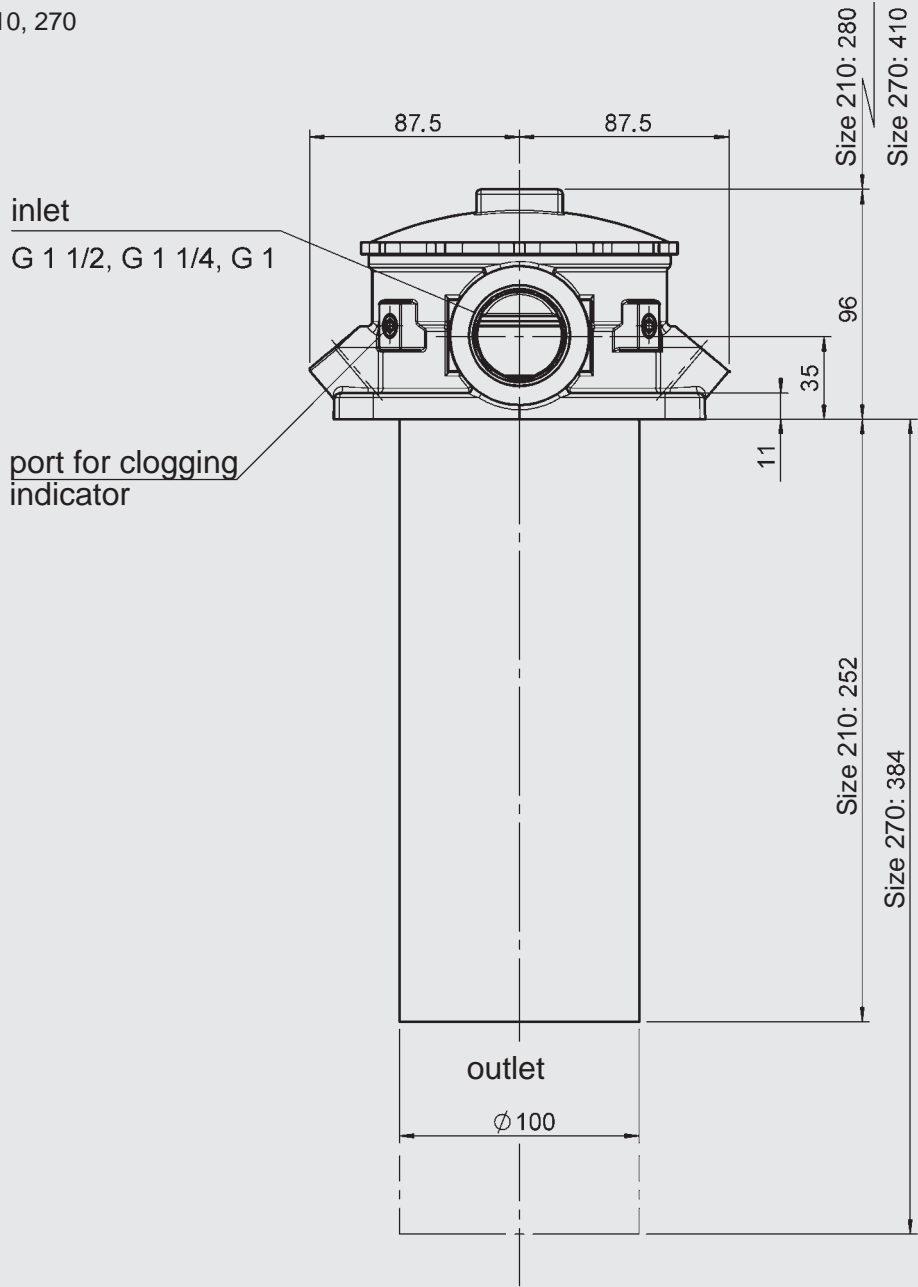

View from below

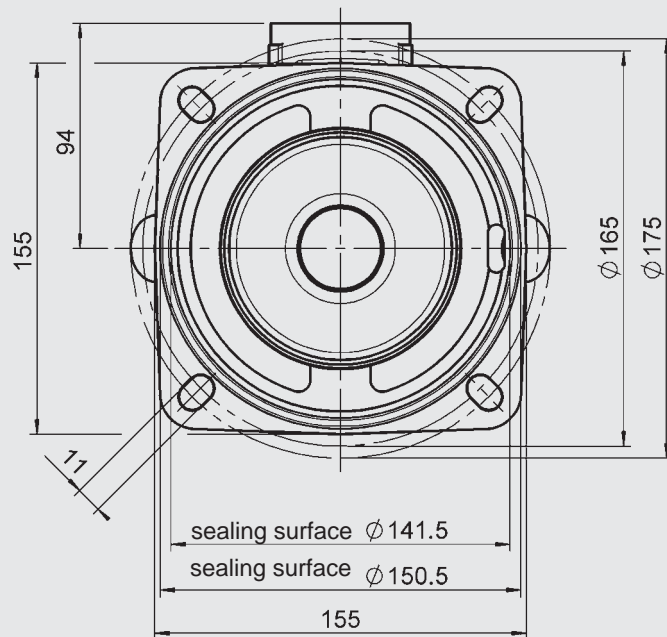

6.4. RFM 330, 500

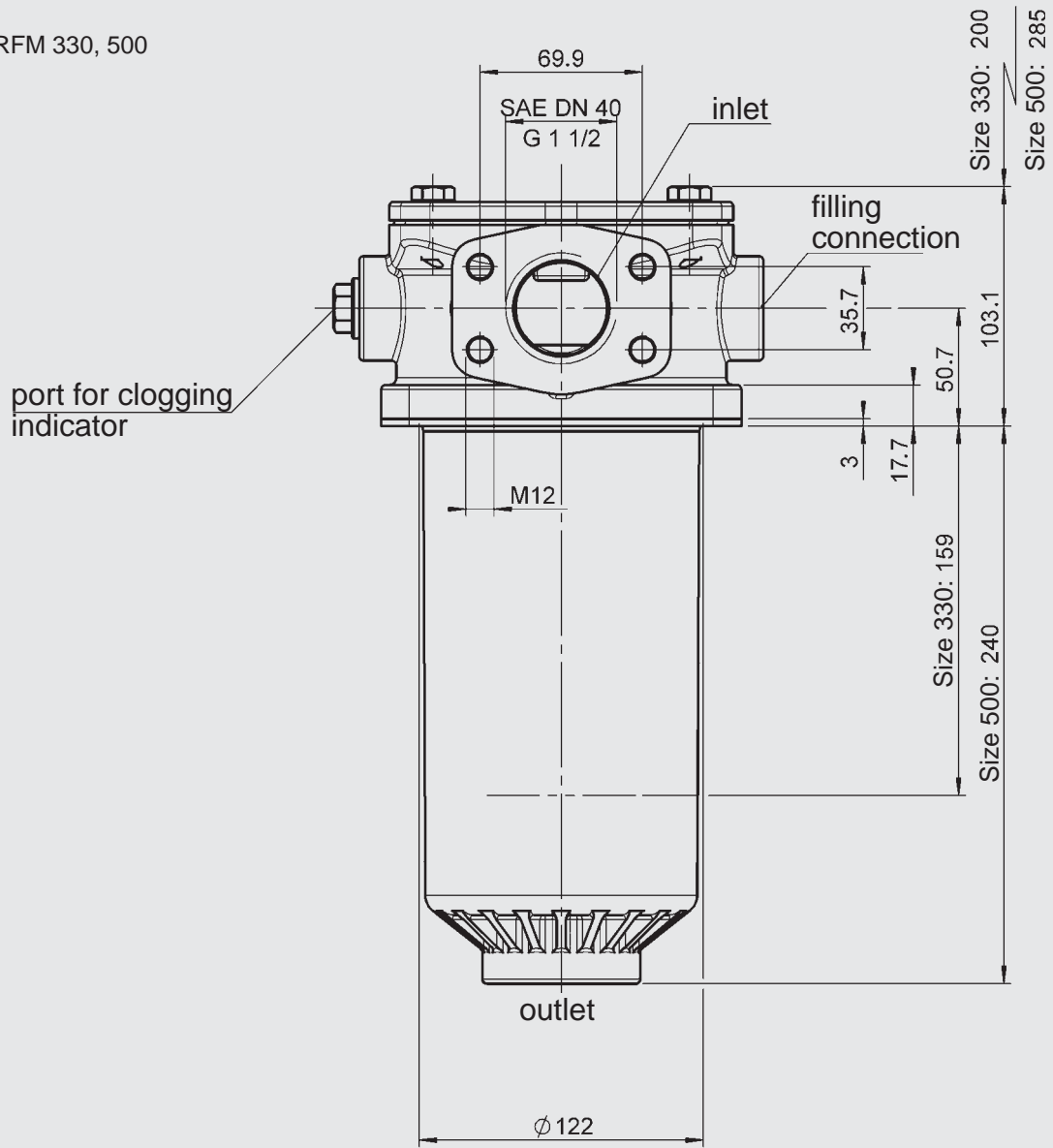

View from below

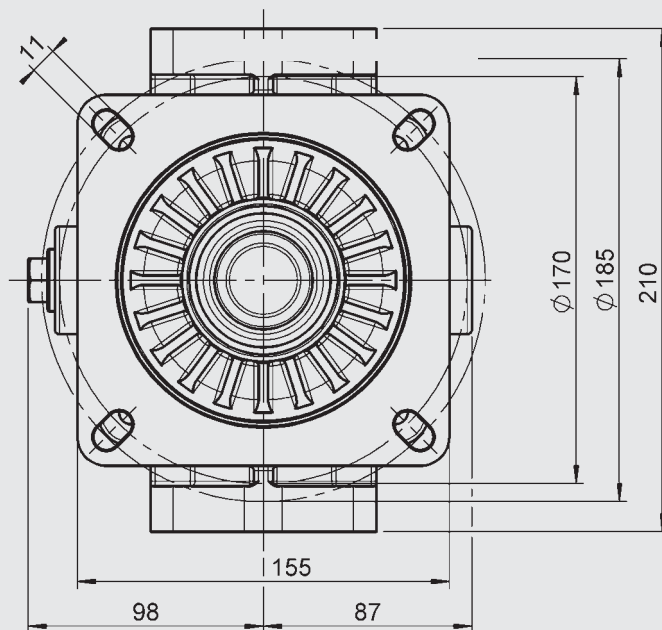

6.5. RFM 661, 851

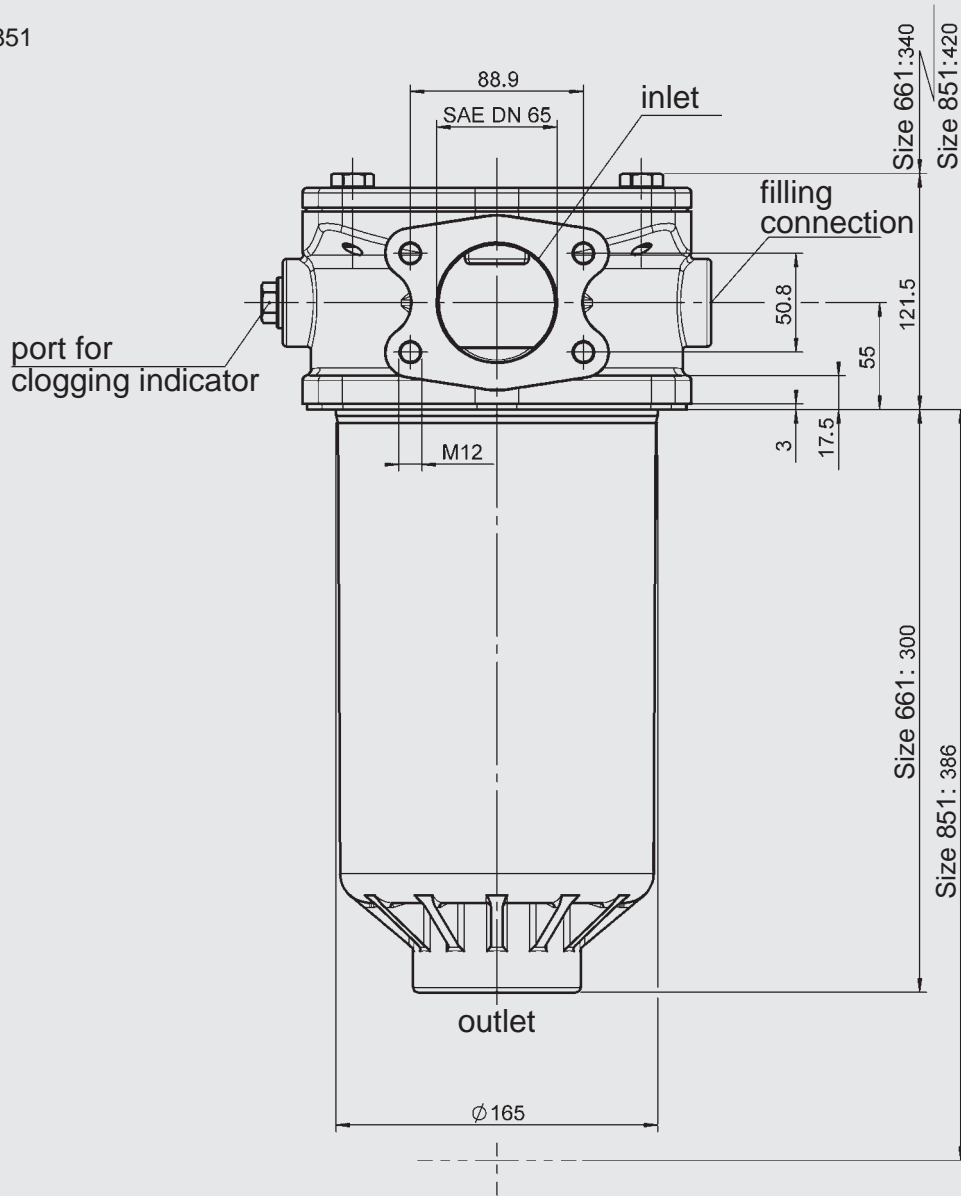

View from below

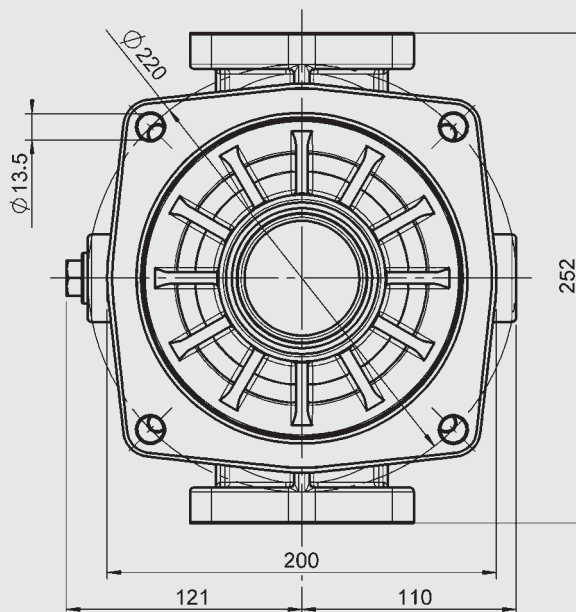

7. NOTE

The information in this brochure relates to the operating conditions and applications described. For applications or operating conditions not described, please contact the relevant technical department. Subject to technical modifications.