

The HYDAC logo is presented in a white, rounded rectangular box with a red border, set against a black background. The word "HYDAC" is written in a bold, white, sans-serif font.

# INTERNATIONAL

## Change-Over Return Line Filter RFD

Flow rates up to 1300 l/min  
Pressure range up to 25 bar  
Material: Al / GGG 40

The image features a 3D CAD model of a HYDAC Return Line Filter RFD. The filter is a cylindrical component with a top cover secured by a hex nut. A prominent red handle is attached to the side, used for manual operation. The model is shown in a perspective view, surrounded by a complex network of green and yellow wireframe lines that represent the filter's internal structure and mounting details. The background is black, which makes the metallic and red components stand out.

HYDAC return line filters type RFD are designed to be mounted directly on tank tops. Inline mounting is also possible.

# 1. TECHNICAL SPECIFICATIONS

## 1.1. FILTER HOUSING

### Construction

The return line filters consist of one-piece housings with bolt-on cover plates.

The two housings are connected by a ball change-over valve with negative overlap and single-lever operation.

Connections for clogging indicators are standard (1 indicator per filter side).

## 1.2. FILTER ELEMENTS

Original Hydac filter elements guarantee reliable function and protect hydraulic components and systems which are sensitive to contamination from wear and tear. Performance and quality tests according to international standards guarantee reliable operation of the filter.

HYDAC filters are validated and their quality is continuously monitored according to the following standards:

- DIN ISO 2941: Verification of collapse / burst resistance
- DIN ISO 2942: Verification of fabrication integrity and determination of first bubble point
- DIN ISO 2943: Verification of material compatibility with fluids
- ISO 3724: Verification of flow fatigue characteristics
- ISO 3968: Evaluation of pressure drop versus flow characteristics
- ISO 4572/ISO16889: Multi-pass method for evaluating filtration performance

In addition to guaranteeing retention and flow rate characteristics, the filter elements have excellent structural stability. The careful construction and mechanically stable support of the filter media guarantee above-average beta value stability and flow fatigue characteristics of the filter elements.

The filter elements are available with the following collapse/burst stability values:

Betamicon®(BN3HC)	: 25 bar
Paper (P/HC)	: 10 bar
Wire mesh (W/HC)	: 30 bar
Stainless steel fibre (V)	: 210 bar
Betamicon®/ Aquamicron®(BN/AM)	: 10 bar
Aquamicron® (AM)	: 10 bar

## 1.3. CLOGGING INDICATORS (example)

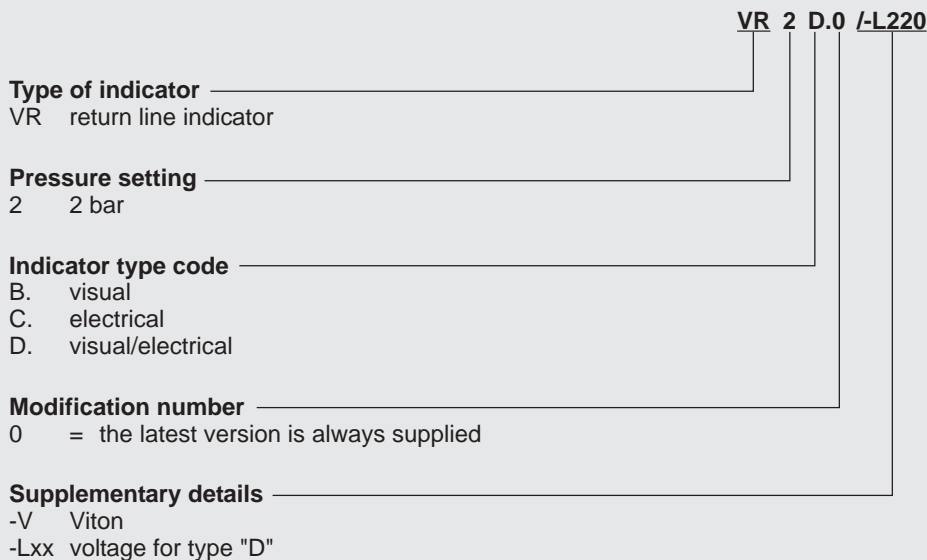

For further details on clogging indicators, please see:  
**Brochure no.: E 7.050../.**

## 1.4. SEALS

Choice of Perbunan (= NBR) or Viton (= FPM) for HFD fluids

## 1.5. SPECIAL MODELS AND ACCESSORIES

- Filter housings size 330 in GGG 40 (SG iron)
- Filter housing surface electro-less nickel-plated (only possible on GGG 40)
- Mating flanges available for filters from size 330 and above

## 1.6. SPARE PARTS

See Original Spare Parts List and Maintenance Instructions

## 1.7. COMPATIBILITY WITH OPERATING FLUIDS

DIN ISO 2943:

- Hydraulic oils H to HLPD to DIN 51524
- Lubrication oils to DIN 51517, APJ, ACEA, DIN 51515, ISO 6743
- Compressor oils to DIN 51506
- Rapidly biodegradable operating fluids to VDMA 24568 HETG, HEES, HEPG
- Non-flam operating fluids HFC and HFD
- Operating fluids with high water content (>50 % water content) on request

For further details on filter elements:

**Brochure no.: E 7.200../.**

# 2. GENERAL

## Mounting

Tank-top filter or inline filter

## Direction of flow

Inlet: via ball valve between the housings

Outlet: vertically down

## Temperature range

-10 °C ... +100 °C

## Pressure setting of clogging indicator

$\Delta p_a = 2 \text{ bar} -0.2 \text{ bar}$

Other pressure settings on request

## Cracking pressure of bypass valve

$\Delta p_o = 3 \text{ bar} +0.5 \text{ bar}$

Other cracking pressures on request

## Hydraulic symbol

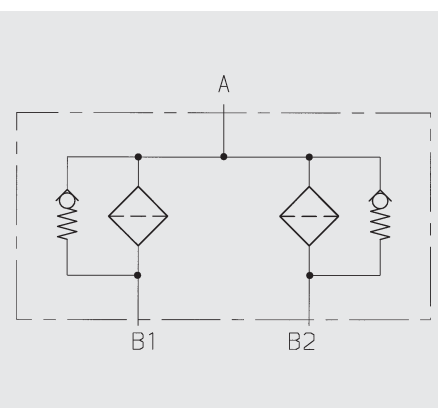

### 3. MODEL CODE

(also order example)

#### 3.1. COMPLETE FILTER

**RFD BN/HC 660 D A N 10 D 1 . X /-L24**

**Filter type**

RFD

**Filter material of element**

- BN/HC Betamicron® (BN3HC)
- AM Aquamicon®
- BN/AM Betamicron®/Aquamicon®
- P/HC paper
- W/HC stainless steel wire mesh
- V stainless steel fibre

**Size / Housing material**

- Aluminium: 60, 110, 160, 240, 330
- SG iron (GGG40): 660, 950, 1300

**Operating pressure**

D = 25 bar

**Type of change-over**

A = ball

**Type of connection / Connection size**

Code	Type of connection	Filter size							
		60	110	160	240	330	660	950	1300
C	G 3/4	●	●						
D	G1			●	●				
G	G2					●			
L	SAE DN 50					●			
N	SAE DN 80						●		
P	SAE DN 100							●	●
Z	According to customer specification								

**Filtration rating in µm**

- BN3HC, V : 3, 5, 10, 20
- BN/AM : 3, 10
- P/HC : 10, 20
- W/HC : 25, 50, 100, 200
- AM : 40

**Type of clogging indicator**

- Y without clogging indicator, with plastic blanking plug in indicator port
  - A without clogging indicator, with steel blanking plug in indicator port
  - B with visual indicator
  - C with electrical indicator
  - D with combined visual/electrical indicator
- ] for other clogging indicators, see brochure no. E 7.050../..

**Type code**

1 standard connection

**Modification number**

X the latest version is always supplied

**Supplementary details**

- V FPM seals, filter suitable for rapidly biodegradable oils and phosphate ester (HFD-R)
- L... light with corresponding voltage (24V, 48V, 110V, 220V) ] only on clogging
- LED 2 light-emitting diodes up to 24 volt ] indicators type D
- KB without bypass valve
- B. special cracking pressure of the bypass valve (B1 = 1 bar, B6 = 6 bar)

3.2. REPLACEMENT ELEMENT  
(also order example)

0330 R 010 BN3HC /-KB

**Size** \_\_\_\_\_  
0060, 0110, 0160, 0240, 0330, 0660, 0950, 1300

**Type** \_\_\_\_\_  
R

**Filtration rating in µm** \_\_\_\_\_  
BN3HC, V : 3, 5, 10, 20  
BN/AM : 3, 10  
P/HC : 10, 20  
W/HC : 25, 50, 100, 200  
AM : 40

**Filter material** \_\_\_\_\_  
BN3HC, V, BN/AM, P/HC, W/HC, AM

**Supplementary details** \_\_\_\_\_  
V = FPM seals, filter suitable for rapidly biodegradable oils and phosphate ester (HFD-R)  
W = only for V and W/HC elements: NBR seals, filter suitable for oil-water emulsions (HFA, HFC)  
KB = without bypass valve  
B. = special bypass cracking pressure (B1 = 1 bar, B6 = 6 bar)

4. FILTER SPECIFICATIONS

Filter type	Connection (inlet)	Element size	Number of elements per filter side	Weight [kg] with element
60	G 3/4	0060 R...	1	3.2
110	G 3/4	0110 R...	1	3.7
160	G1	0160 R...	1	7.0
240	G1	0240 R...	1	7.8
330	G2	0330 R...	1	13.4
	SAE DN 50			
660	SAE DN 80	0660 R...	1	50.9
950	SAE DN 100	0950 R...	1	97.5
1300	SAE DN 100	1300 R...	1	108.0

## 5. FILTER CALCULATION / SIZING

The total pressure drop of a filter at a certain flow rate is the sum of the housing  $\Delta p$  and the element  $\Delta p$ . The pressure drop can either be determined with the aid of our HFS Filter Sizing Program, which is available free of charge, or by using the following graphs.

NEW: Sizing online at [www.hydac.com](http://www.hydac.com) (please click on the following buttons: Products-Filters-Electronic catalogue-Filter sizing HFS)

### 5.1. $\Delta P$ -Q HOUSING GRAPHS TO ISO 3968

The housing graphs apply to mineral oil with a density of  $0.86 \text{ kg/dm}^3$  and a kinematic viscosity of  $30 \text{ mm}^2/\text{s}$  for, in each case, the largest nominal width per size.

For turbulent flows, the differential pressure changes proportionally to the density. For laminar flows it changes proportionally to the density and the viscosity.

#### RFD 60/110

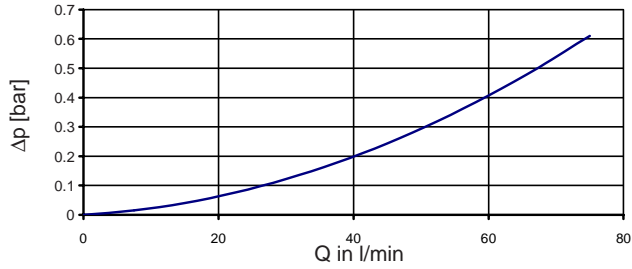

#### RFD 160/240

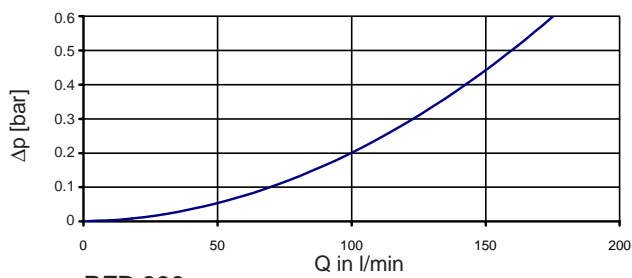

#### RFD 330

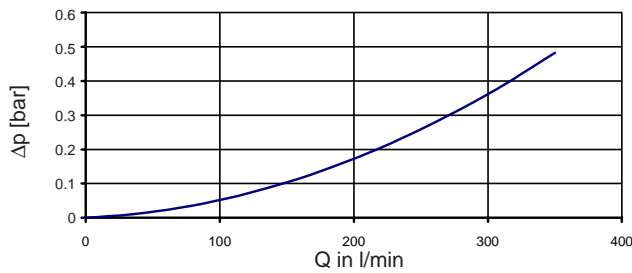

#### RFD 660

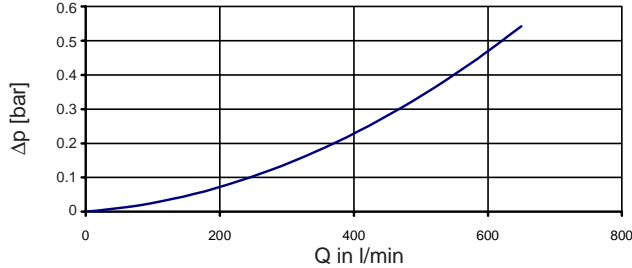

#### RFD 950/1300

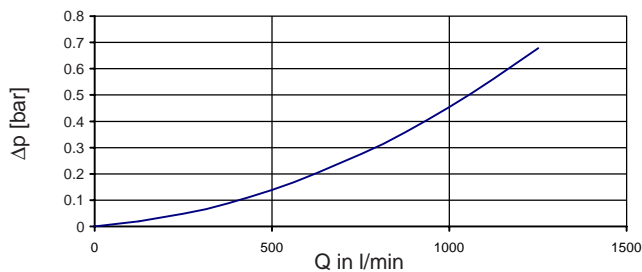

### 5.2. $\Delta P$ -Q GRAPHS - FILTER ELEMENTS

The element graphs apply to mineral oil with a kinematic viscosity of  $30 \text{ mm}^2/\text{s}$ .

The pressure drop changes proportionally to the change in viscosity (see Example 5.3.).

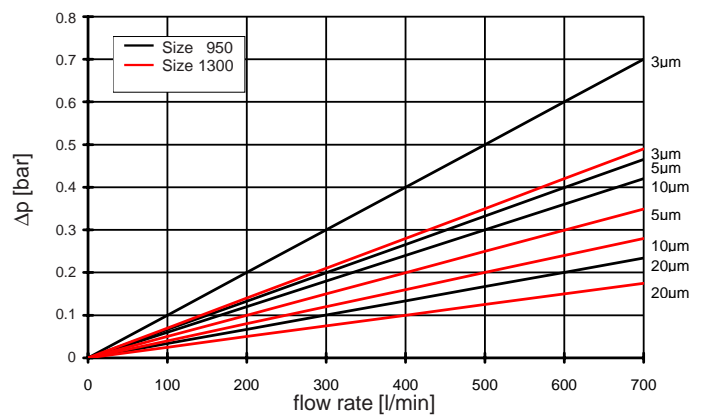
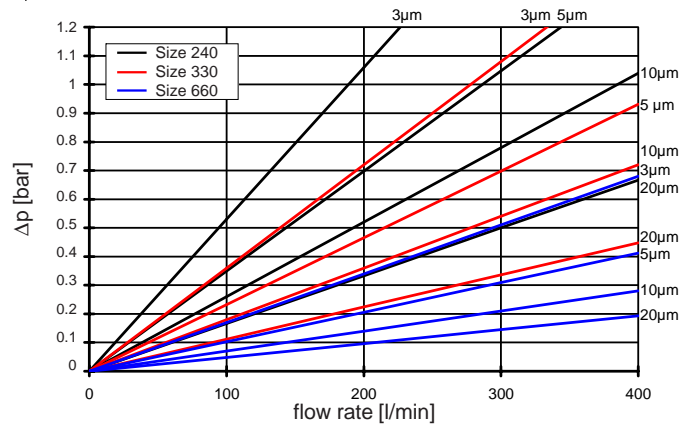
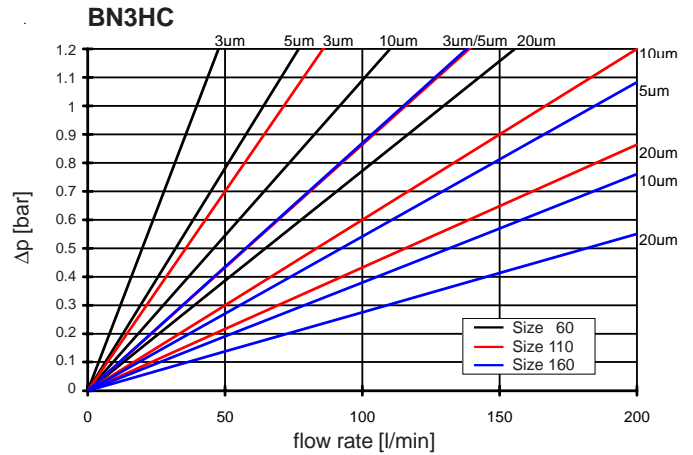

V

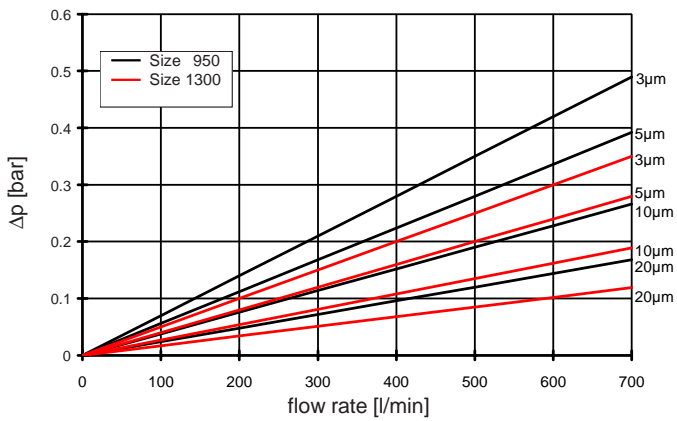
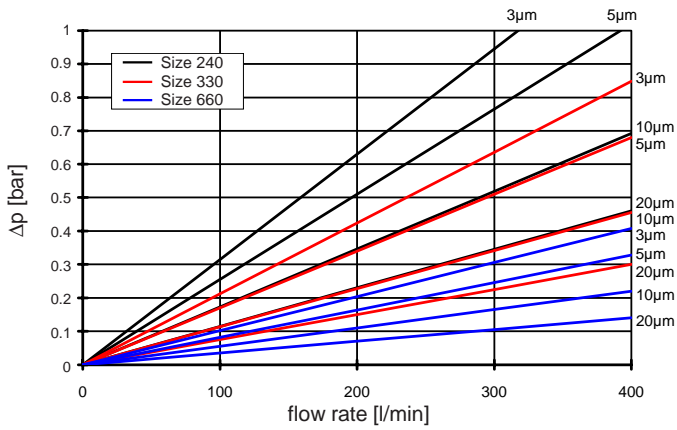
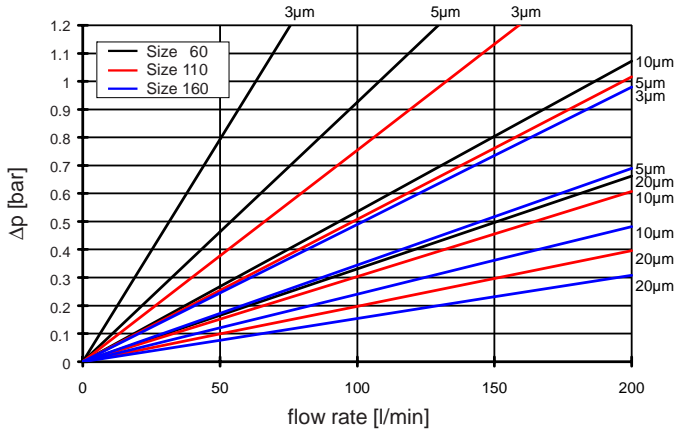

W/H C

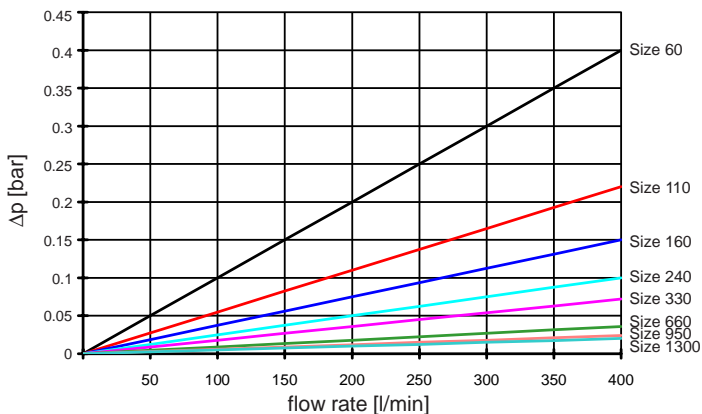

P/HC (10 µm)

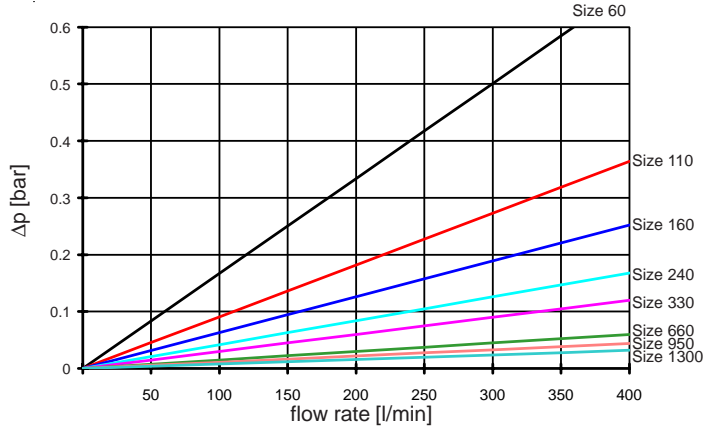

P/HC (20 µm)

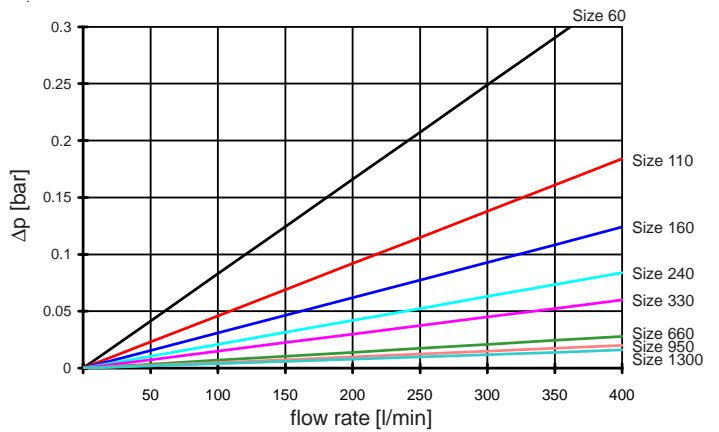

5.3. EXAMPLE

General:

$$\Delta p_{\text{total}} = \Delta p_{\text{housing}} + \Delta p_{\text{element}} \cdot \frac{\text{viscosity (mm}^2/\text{s)}}{30 \text{ mm}^2/\text{s}}$$

$\Delta p_{\text{housing}}$  = to be determined from point 5.1.

$\Delta p_{\text{element}}$  = element pressure drop at flow rate Q/n and viscosity 30 mm<sup>2</sup>/s according to point 5.2.

Example:

System data: RFD 110 with BN3HC element (10 µm)  
viscosity = 46 mm<sup>2</sup>/s  
(ISO VG 46 at 40 °C)  
Q = 40 l/min

$$\Rightarrow \Delta p_{\text{housing}} = 0.2 \text{ bar (at Q)}$$

$$\Delta p_{\text{element}} = 0.24 \cdot \frac{46}{30} = 0.37 \text{ bar}$$

$$\Delta p_{\text{total}} = \underline{0.57 \text{ bar}}$$

## 6. DIMENSIONS

### 6.1. RFD 60 - 240

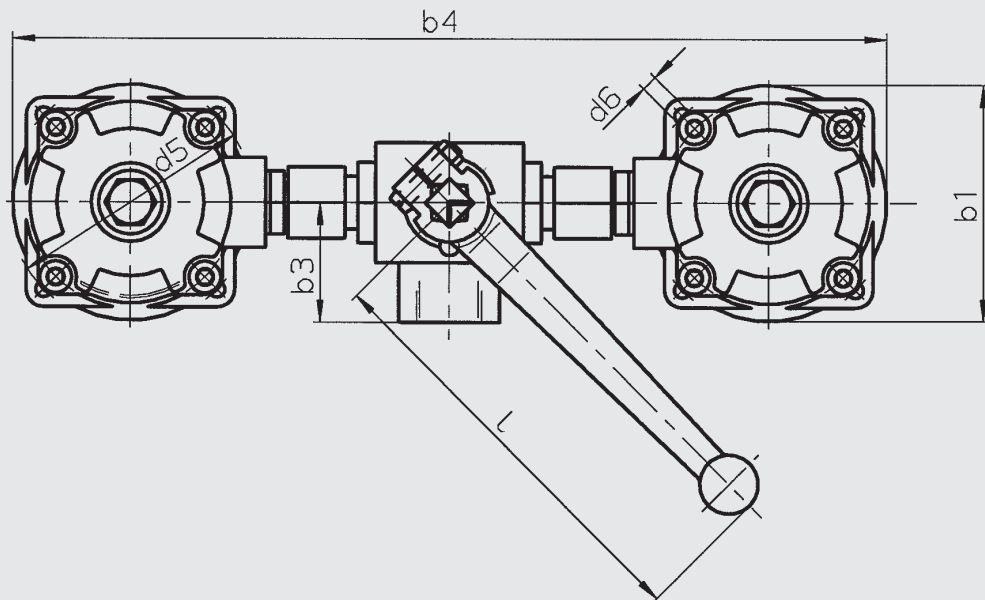
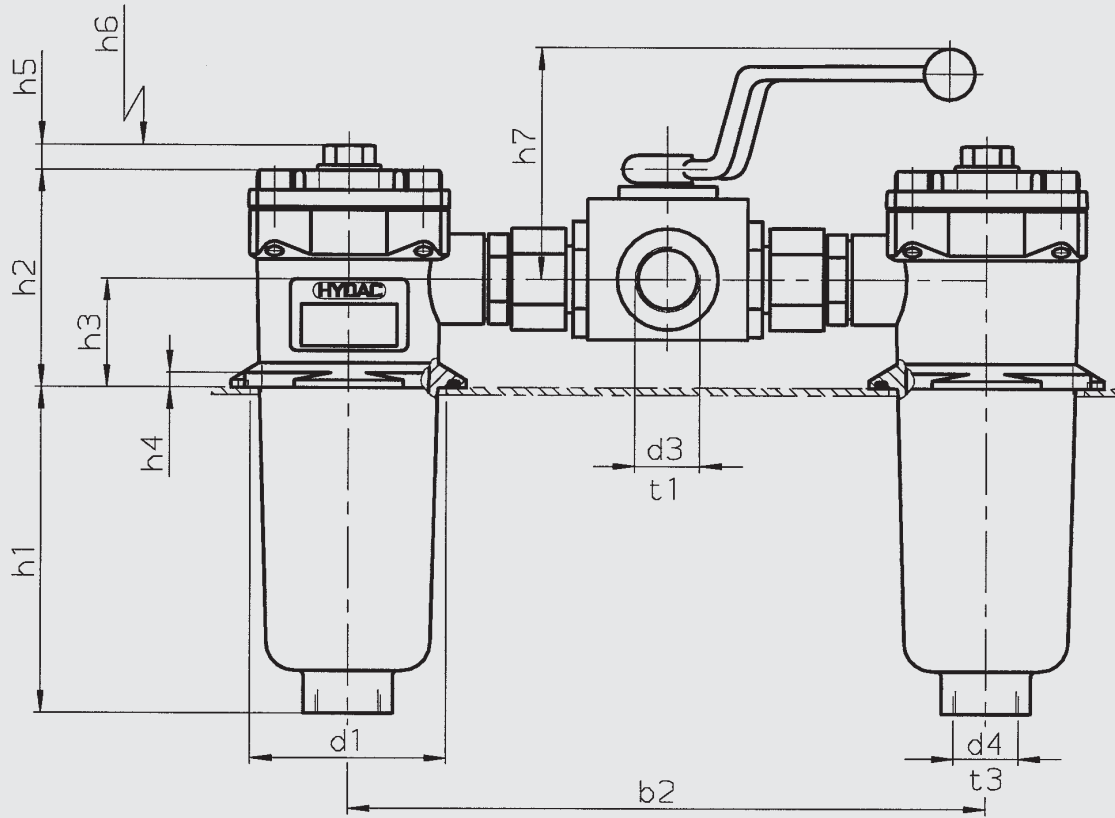

Type	b1	b2±1.5	b3	b4	d1	d3	d4	d5	d6 <sup>1)</sup>	h1	h2	h3	h4	h5	h6	h7	l	t1	t3
RFD 60	96	260.5	47.5	357	80	G ¾	G ¾	100	M5	66	88	44	6	11	80	92	173	16	17
RFD 110	96	260.5	47.5	357	80	G ¾	G ¾	100	M5	133	88	44	6	11	145	92	173	16	17
RFD 160	126	335.5	56.5	461	106	G1	G1¼	135	M6	89	108	54	6	11	120	95	173	24	20
RFD 240	126	335.5	56.5	461	106	G1	G1¼	135	M6	150	108	54	6	11	180	95	173	24	20

<sup>1)</sup> mounting hole for screw

6.2. RFD 330-1300

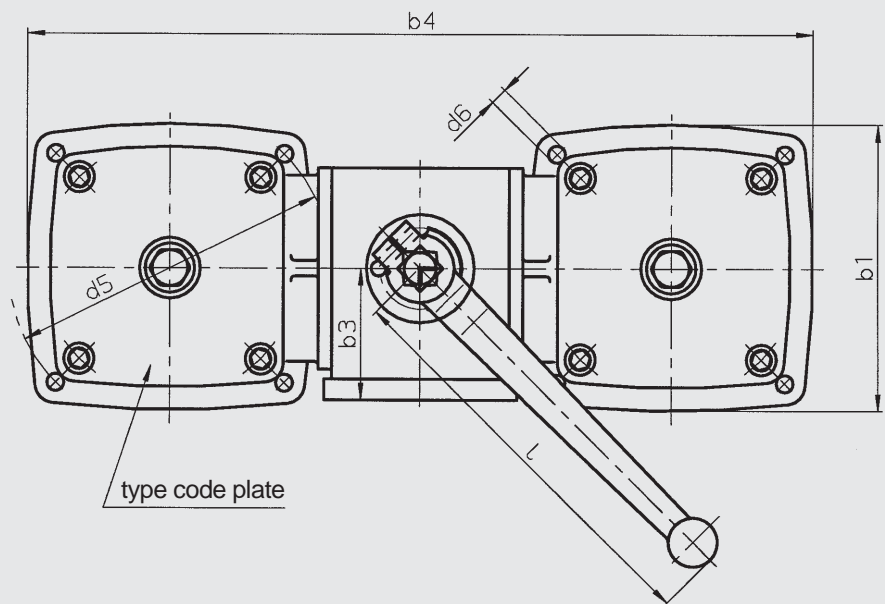
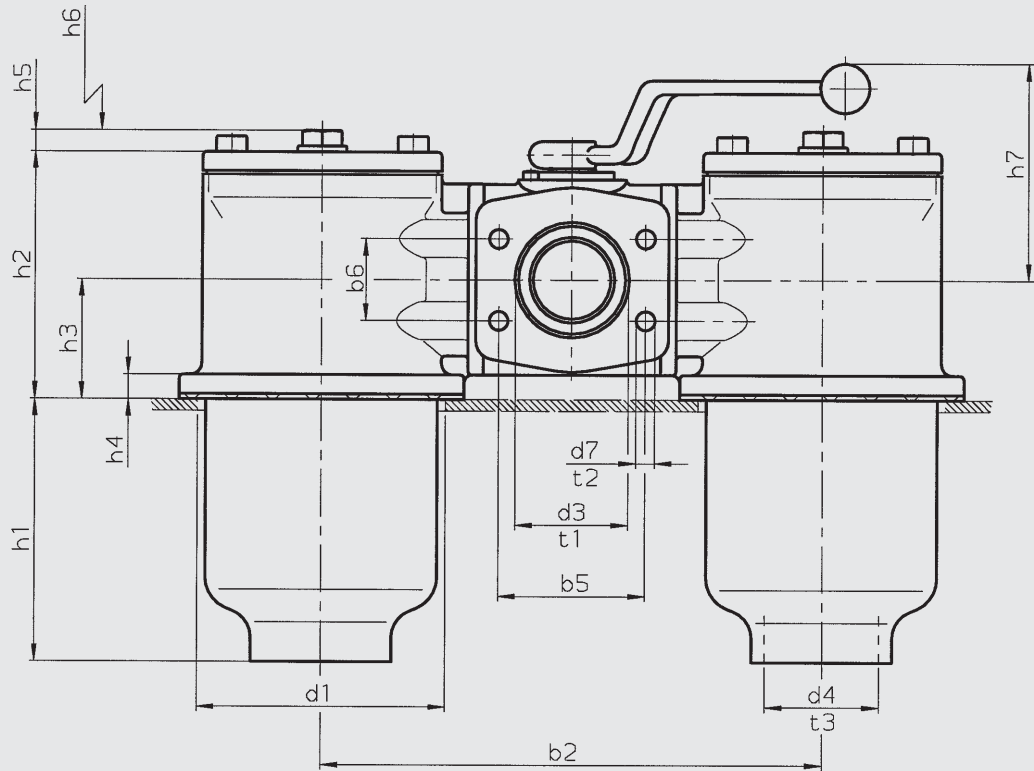

Type	b1	b2±1.3	b3	b4	b5	b6	d1	d3	d4	d5	d6 <sup>1)</sup>	d7	h1	h2	h3	h4	h5	h6	h7	l	t1	t2	t3
RFD 330	150	254	69	404	77.8	42.9	135	G2 SAE DN 50 (2")	G2	170	M8	— M12	138	131	63	13	11	180	120	216	24 —	— 17	— 27
RFD 660	195	330	100	525	106.5	61.9	180	SAE DN 80 (3")	G3	220	M12	M16	243	167	83	13	11	320	130	216	—	20	32
RFD 950	250	390	140	640	130.2	77.8	208	SAE DN 100 (4")	SAE DN 90 (3½")	290	M16	M16	251	198	93	13	11	350	180	301	—	25	—
RFD 1300	250	410	140	660	130.2	77.8	208	SAE DN 100 (4")	SAE DN 100 (4")	290	M16	M16	332	241	121	13	11	460	180	301	—	25	—

Filter connection for SAE flanges to SAE-J 518c / 3000 psi

<sup>1)</sup> mounting hole for screw

7. NOTE

The information in this brochure relates to the operating conditions and applications described.  
For applications or operating conditions not described, please contact the relevant technical department.  
Subject to technical modifications.

