

Pressure Filters for reversible flow DFF/DFG

1. DESCRIPTION

1.1. GENERAL

Pressure filters for reversible oil flow, type DFF, filter the hydraulic fluid in one direction. During reverse flow, the fluid is not filtered.

Pressure filters type DFG, using the Wheatstone Bridge Principle (4 check valves), filter the hydraulic fluid in both flow directions.

Unscrewing the filter bowl allows fast cleaning or changing of the filter element.

1.2. FILTER HOUSING

The pressure filter type DFF for reversible flow consists of a filter head made from spheroidal graphite casting and a screw-on filter bowl in cold impact pressed steel.

The pressure filter type DFG for both flow directions consists of a filter head in steel and a screw-on filter bowl in cold impact pressed steel. The parts are designed to absorb high continuous pressure and pressure peaks.

The basic models come without a clogging indicator. However, they can be supplied with visual, electrical or electronic clogging indicators, or these can be fitted subsequently.

Please note:

If a clogging indicator is fitted, this must be tightened to the appropriate torque rating. Please refer to brochure no. E 7.050../.. Clogging Indicators for Filters.

1.3. FILTER ELEMENTS

See brochure no. E 7.200../..

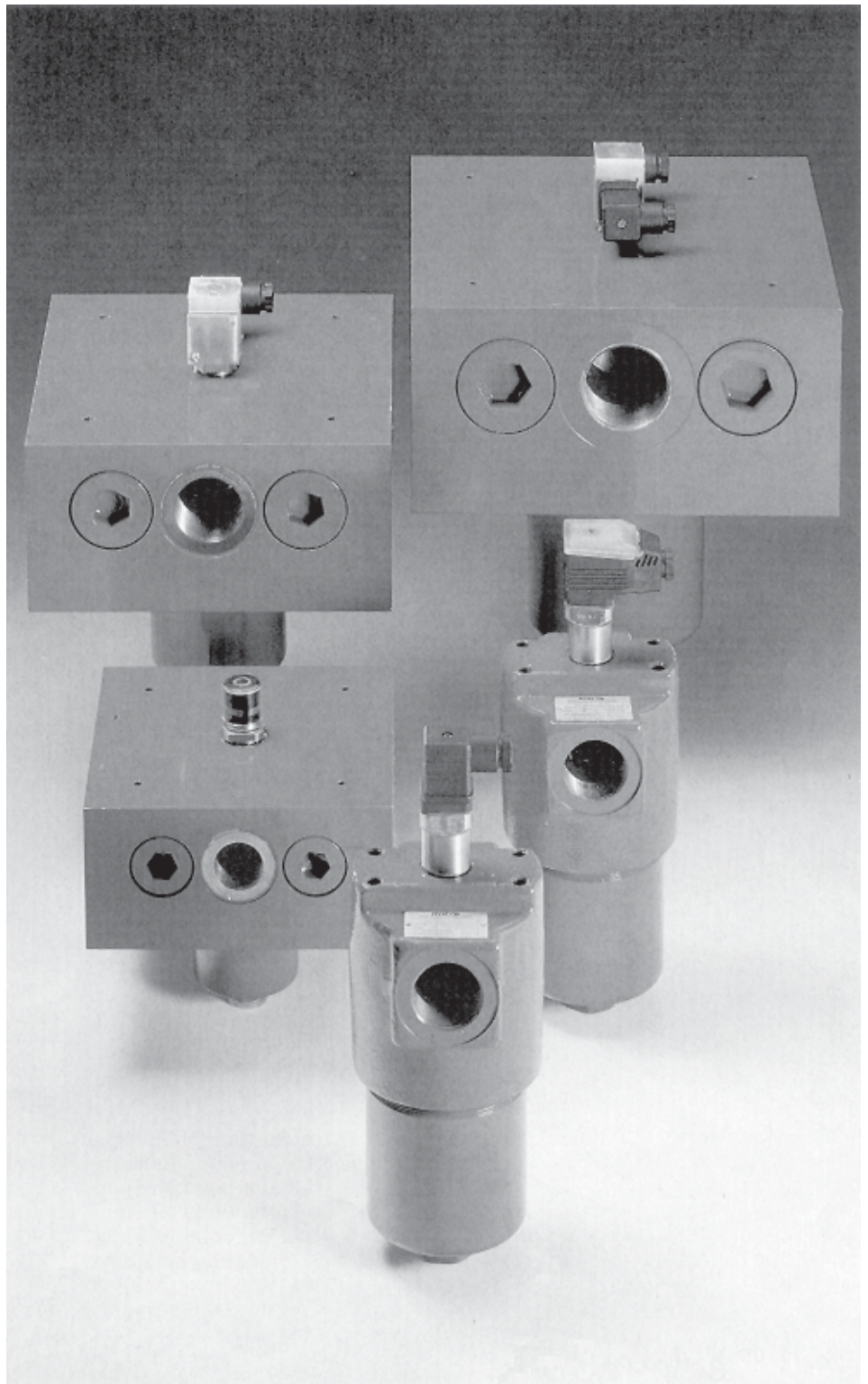

2. TECHNICAL SPECIFICATIONS

2.1. GENERAL

2.1.1 Designation and symbols

Pressure filters

for reversible oil flow (DFF)
(optionally with differential pressure indicator)

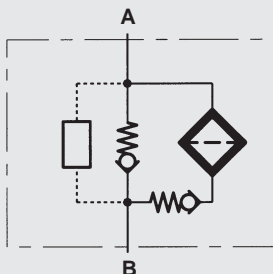

for filtration in both directions (DFG)
(optionally with differential pressure indicator)

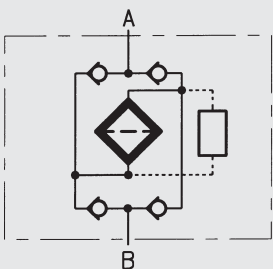

2.1.2 Model Code (also order example)

DFF BH/HC 160 G 20 C 1 . X / -V

Filter type

DFF = pressure filter for filtration in one direction
reverse oil flow - no filtration

DFG = pressure filter for filtration in both directions

Filter material of element

BH/HC Betamicon®-H3HC element } absolute filtration

BN/HC Betamicon®-N3HC element } absolute filtration

V Metal fibre } nominal filtration

W/HC Wire mesh } nominal filtration

Size

60
110
140
160
240
280
330¹⁾
500¹⁾
660¹⁾

flow rate, viscosity and application conditions must be taken into account

Type of connection

G = threaded connection

F = flange connection

Filtration rating in micron

3 } Betamicon®-H (BH3HC) } absolute filtration

5 } Betamicon®-N (BN3HC) } absolute filtration

10 } Metal fibre (V) } nominal filtration

20 } Wire mesh (W) } nominal filtration

25 } Wire mesh (W) } nominal filtration

Type of clogging indicator

A = without clogging indicator

B = with visual indicator

C = with electrical indicator

D = with combined visual/
electronic indicator

see clogging indicator
brochure
n° E 7.050../..

Cracking pressure 8 bar - standard

Type code

1 = standard

Modification number

x = filter is always supplied in the latest version

Supplementary details

no supplementary details = standard model

-V = FPM (Viton) seals, filter suitable for phosphate ester (HFD-R)

-W = filter suitable for oil-water emulsion (HFA), water polymer solution (HFC)

-L 24 = lamp with 24 V DC

-L 48 = lamp with 48 V DC

-L 110 = lamp with 110 V DC

-L 220 = lamp with 220 V DC

-LED = 2 light emitting diodes up to 24 V

-So184 = pressure release/oil drain plug (up to size 280)

on type D
indicators only

¹⁾ with pressure release/oil drain plug as standard

2.1.3 Construction

Inline filter

2.1.4 Mounting method

4 mounting holes in the filter head

2.1.5 Approx. weight

	with element	without element
DFF 60	4.1 kg	3.9 kg
DFF 110	6.0 kg	5.7 kg
DFF 140	6.6 kg	6.2 kg
DFF 160	9.6 kg	9.1 kg
DFF 240	11.3 kg	10.6 kg
DFF 280	15.9 kg	14.5 kg
DFF 330	22.6 kg	21.4 kg
DFF 500	26.9 kg	25.2 kg
DFF 660	30.5 kg	28.3 kg
DFG 60	23.9 kg	23.7 kg
DFG 110	24.8 kg	24.5 kg
DFG 140	25.4 kg	25.0 kg
DFG 160	47.0 kg	46.5 kg
DFG 240	48.6 kg	47.9 kg
DFG 280	53.2 kg	51.8 kg
DFG 330	89.1 kg	87.9 kg
DFG 500	93.4 kg	91.7 kg
DFG 660	97.7 kg	95.5 kg

2.1.6 Housing volumes

DFF 60	0.20 ltr.
DFF 110	0.33 ltr.
DFF 140	0.40 ltr.
DFF 160	0.60 ltr.
DFF 240	0.80 ltr.
DFF 280	1.45 ltr.
DFF 330	1.50 ltr.
DFF 500	2.30 ltr.
DFF 660	3.00 ltr.
DFG 60	0.20 ltr.
DFG 110	0.33 ltr.
DFG 140	0.40 ltr.
DFG 160	0.60 ltr.
DFG 240	0.80 ltr.
DFG 280	1.45 ltr.
DFG 330	1.50 ltr.
DFG 500	2.30 ltr.
DFG 660	3.00 ltr.

2.1.7 Pipe connection sizes

(threaded connection to ISO 228)

DFF 60 G = G 3/4
DFF 110 G = G 3/4
DFF 140 G = G 3/4
DFF 160 G = G 1 1/4
DFF 240 G = G 1 1/4
DFF 280 G = G 1 1/4
DFF 330 G = G 1 1/2
DFF 330 F = SAE-flange DN 50/6000 psi
DFF 500 G = G 1 1/2
DFF 500 F = SAE-flange DN 50/6000 psi
DFF 660 G = G 1 1/2
DFF 660 F = SAE-flange DN 50/6000 psi
DFG 60 G = G 1
DFG 110 G = G 1
DFG 140 G = G 1
DFG 160 G = G 1 1/2
DFG 240 G = G 1 1/2
DFG 280 G = G 1 1/2
DFG 330 G = G 2
DFG 500 G = G 2
DFG 660 G = G 2

2.1.8 Mounting position

Vertical

2.1.9 Flow direction

Inlet: side connection
 Outlet: side connection
 At the same height
 on opposite sides

2.2. HYDRAULIC DETAILS

2.2.1 Operating pressure/temperature

The permissible operating pressure is generally dependent on the operating temperature.

If $\delta_{min} \dots \delta_{max} \dots = -10 \text{ }^\circ\text{C} \dots +100 \text{ }^\circ\text{C}$

DFF: $p_{max} = 420 \text{ bar}$

DFG: $p_{max} = 420 \text{ bar}$

If $\delta_{min} \dots \delta_{max} \dots = -30 \text{ }^\circ\text{C} \dots -10 \text{ }^\circ\text{C}$

(only possible with

NBR (Perbunan) seals)

DFF: $p_{max} = 220 \text{ bar}$

DFG: $p_{max} = 220 \text{ bar}$

Proof of fatigue strength for complete filters to HYDAC Test Standard: min. 1 million cycles, rising from 0 bar to permissible operating pressure ($=p_{max}$).

For other temperature ranges, please contact our sales/technical department.

2.2.2 Permissible Δp across element

Betamicron[®]-H (BH3HC): 210 bar

Betamicron[®]-N (BN3HC): 25 bar

Metal fibre (V/HC): 210 bar

Wire mesh (W/HC): 30 bar

2.2.3 Compatibility with hydraulic media

Mineral oils:

Test criteria to ISO 2943

Lubricating oils:

Test criteria to ISO 2943

For use with water, non-flam fluids, synthetic and rapidly biodegradable oils etc., please contact our sales/technical department.

2.2.4 Flow fatigue resistance to DIN/ISO 3724

High flow fatigue resistance due to solid filter material supports on both sides and high wet strength of the filter materials.

2.2.5 Pressure setting of differential pressure indicator

$\Delta p_a = 8 \text{ bar} \pm 10 \%$

2.2.6 Δp -Q Graphs to ISO 3968

Housing Graphs

The housing graphs are based on mineral oil with a density of 0.86 kg/dm^3 and a kinematic viscosity of $30 \text{ mm}^2/\text{s}$.

For turbulent flows the differential pressure changes proportionally to the density. For laminar flows it changes proportionally to the density and the viscosity.

2.2.7 Filter elements

For filter selection, see Filter Elements brochure No. E 7.200../..

The element pressure drop must be added to the housing pressure drop.

DFF 60/110/140

Forward flow

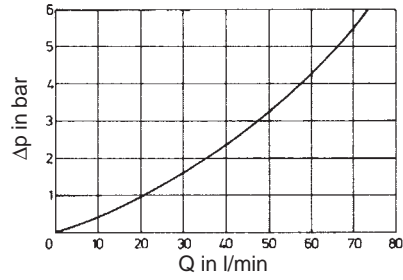

Reverse flow

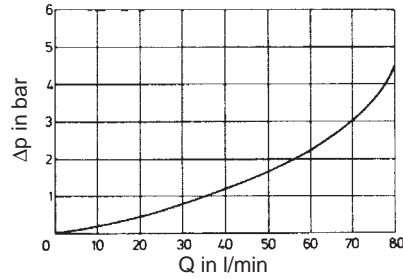

DFF 160/240/280

Forward flow

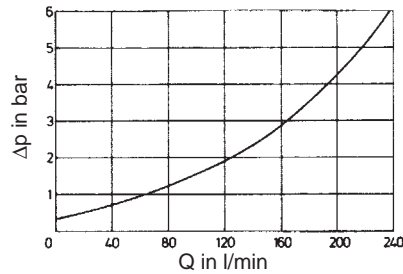

Reverse flow

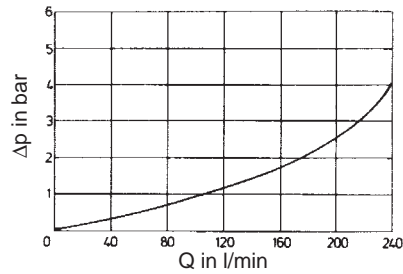

DFF 330/500/660

Forward flow

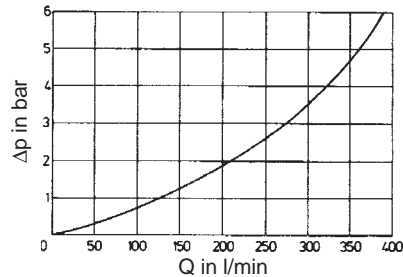

Reverse flow

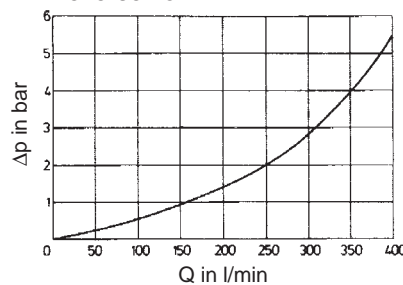

DFG 60/110/140

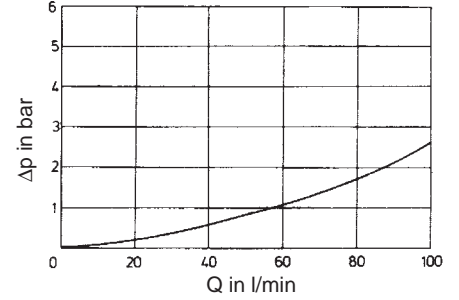

DFG 160/240/280

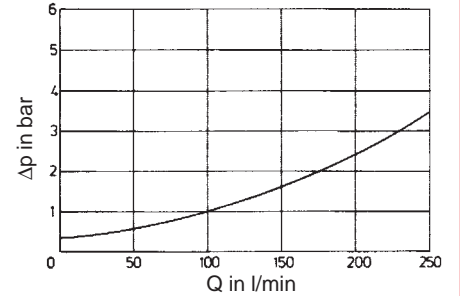

DFG 330/500/660

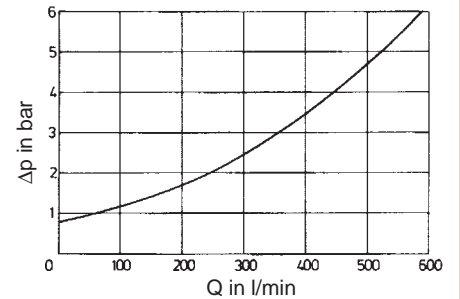

3. DIMENSIONS: DFF

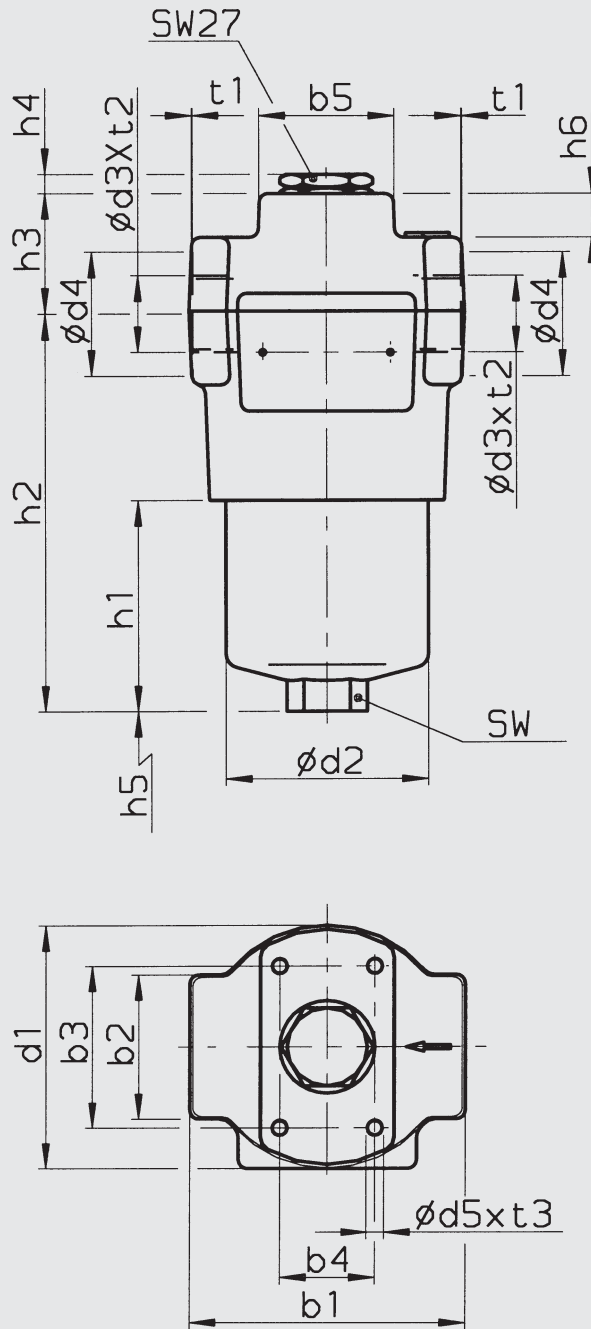

Type	b ₁	b ₂	b ₃	b ₄	b ₅	ød ₁	ød ₂	ød ₃	ød ₄	ød ₅	h ₁	h ₂	h ₃	h ₄	h ₅	h ₆	SW	t ₁ *	t ₂ *	t ₃ *
DFF 60 G ...	93	50	56	32	45	84	68	G¾	42	M 6	72.5	137	40	6	85	15	27	1	17	9
DFF 110 G ...											139.5	204								
DFF 140 G...											183.5	248								
DFF 160 G ...	128	65	85	35	50	117	95	G1¼	58	M10	106	193	47	6	105	14.5	32	1	21	14
DFF 240 G ...											166	253								
DFF 280 G ...											348	435								
DFF 330 G ...	167	138	115	60	80	169	130	G1½	65	M12	156	235	52	6	115	9.5	36	1	23	17
DFF 330 F ...	160							156			235									
DFF 500 G ...	167							G1½			249	328								
DFF 500 F ...	160							SAE DN 50			249	328								
DFF 660 G ...	167							G1½			327	405.5								
DFF 660 F ...	160	SAE DN 50	327	406																

* thread to ISO 228

DIMENSIONS: DFG

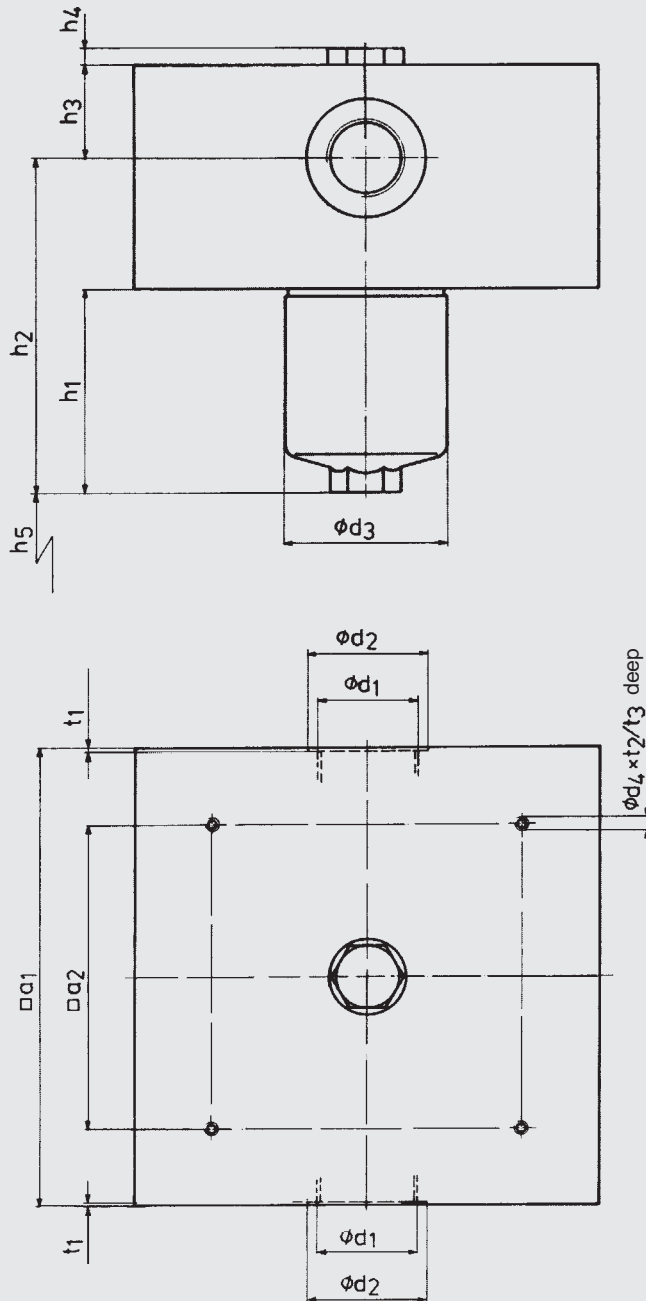

Type	a_1	a_2	d_1^*	d_2	d_3	d_4	t_1	t_2	t_3	h_1	h_2	h_3	h_4	h_5
DFG 60 G ...	194	129	G 1	50	68	M 6	1	7	10	86	141	39	7	75
DFG 110 G ...										154	209			
DFG 140 G...										193	248			
DFG 160 G ...	245	165	G 1 ½	68	95	M 8	1	9	13	116	189	48	7	85
DFG 240 G ...										175	248			
DFG 280 G ...										358	431			
DFG 330 G ...	300	210	G 2	96	130	M 8	1	9	13	166	259	57	7	95
DFG 500 G ...										259	352			
DFG 660 G ...										337	430			

* thread to ISO 228

4. PLEASE NOTE

The information in this brochure relates to the operating conditions and applications described. For applications or operating conditions not described, please contact the relevant technical department.
Subject to technical modifications.