

HYDAC

INTERNATIONAL

Manifold Mounted, Rear Flanged

Pressure Filters

DF...M A / DF...Q E

DF...MHA / DF...MHE

Flow rates up to 500 l/min

Pressure range up to 315 bar

Material: SG Iron/ADI, Steel

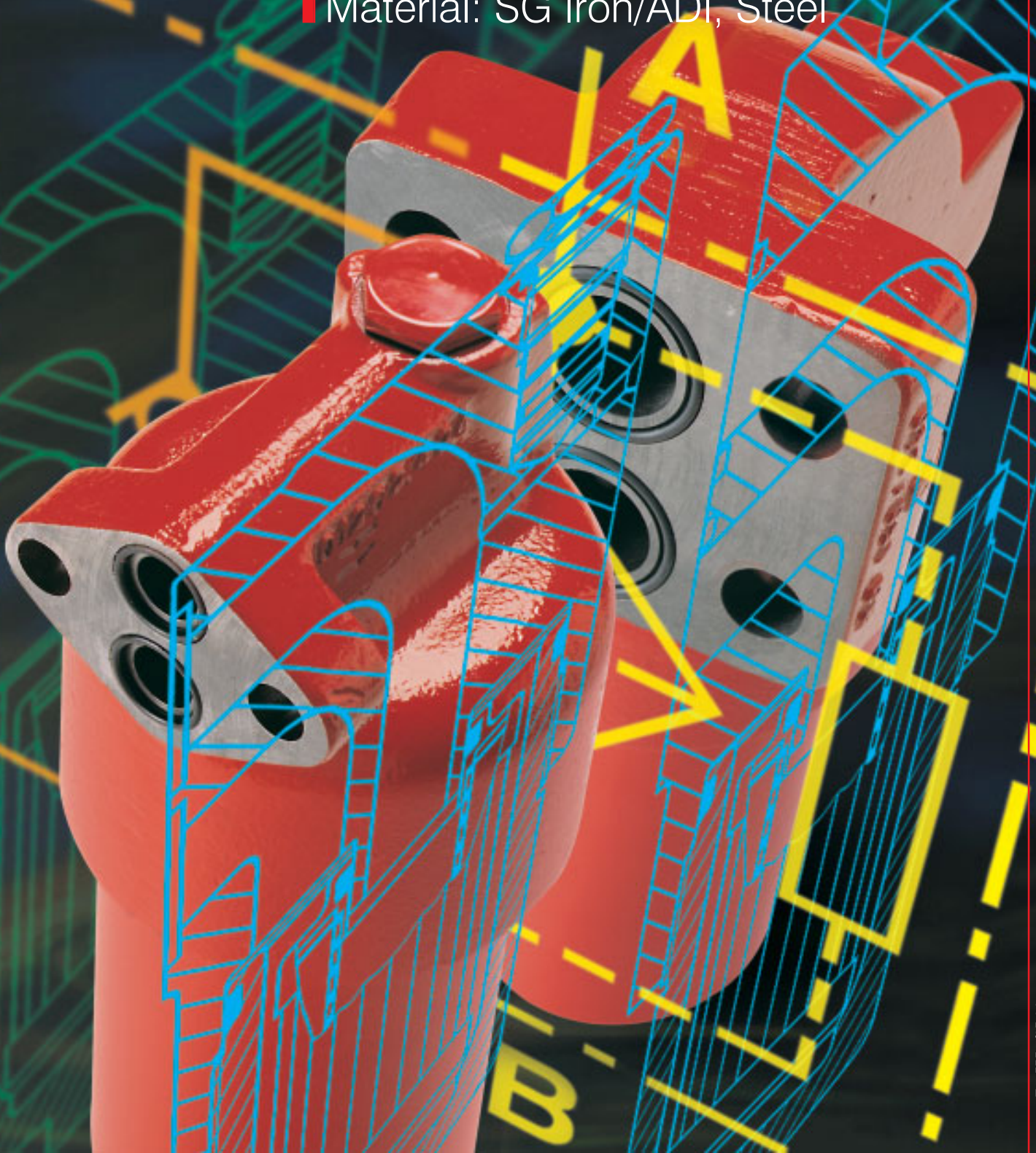

1. DESCRIPTION

1.1. FILTER HOUSING

Construction

The filter housings have been designed in accordance with international regulations. They consist of a filter head and a screw-in filter bowl.

Standard specification:

- Mounting holes in the head
- 2-piece bowl for size 660 and above
- Suitable for HFA/HFC fluids
- Oil drain plug with automatic pressure relief (for size 330 and above)

Interface

- DF 60-280 M A / DF 160-280 MHA:
Outlet above inlet

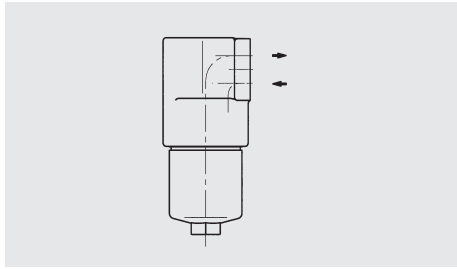

- DF 30-280 Q E:
Inlet above outlet

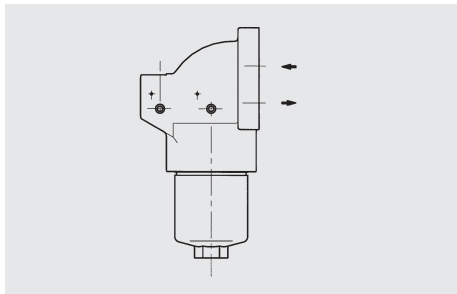

option (size 160, 240, 280):
Outlet above inlet (.../-OAI)

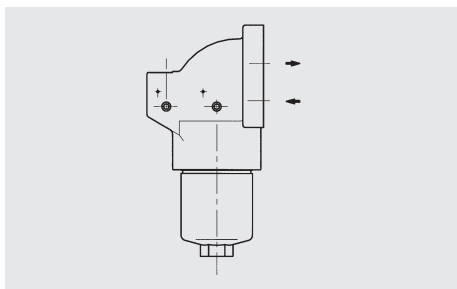

- DF 330-1320 Q E / DF 330-1320 MHE:
Outlet above inlet

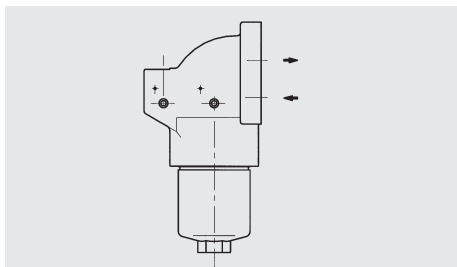

1.2. FILTER ELEMENTS

Original HYDAC filter elements guarantee reliable function and protect hydraulic components and systems which are sensitive to contamination from wear and tear.

Performance and quality tests in accordance with international standards guarantee reliable operation of the filter.

Hydac filters are validated and their quality is continuously monitored according to the following standards.

- ISO 2941:
Verification of collapse / burst resistance
- ISO 2942:
Verification of fabrication integrity and determination of first bubble point test
- ISO 2943:
Verification of material compatibility with fluids
- ISO 3724:
Verification of flow fatigue characteristics
- ISO 3968:
Evaluation of differential pressure versus flow characteristics
- ISO 16889:
Multi-pass method for evaluating filtration performance of a filter element

In addition to guaranteeing retention and flow rate characteristics, the filter elements have excellent structural stability.

The careful construction and mechanically stable support of the filter media guarantee above-average beta value stability and flow fatigue characteristics of the filter elements.

The filter elements are available with the following collapse/burst stability values:

Betamicon®(BH3HC)	: 25 bar
Betamicon®(BN3HC)	: 210 bar
Wire mesh (W/HC)	: 30 bar
Stainless steel fibre (V)	: 210 bar

1.3. CLOGGING INDICATORS

VD 5 D . 0 /-L220

Type of indicator

VD differential pressure indicator up to 450 bar operating pressure
VM differential pressure indicator up to 210 bar operating pressure

Pressure setting

5 5 bar = standard (others on request)

Indicator type code (options)

B. = visual
C. = electrical
D. = visual/electrical

Modification number

0 the latest version is always supplied

Supplementary details

-V Viton
-LED 2 light-emitting diodes up to 24 volt
-L.. light with corresponding voltage (24, 48, 110, 220 volt)
-W only for oil-water emulsions HFA, HFC (only possible for version "VD")

For further details on clogging indicators, please see:

brochure no.: E 7.050../.

1.4. SEALS

Perbunan (= NBR).

1.5. SPECIAL MODELS AND ACCESSORIES

- bypass valve (only for DF...MA/DF...QE)
- oil drain plug up to size 280
- seals in FPM, EPDM
- test and inspection certificates

1.6. SPARE PARTS

See Original Spare Parts List and Maintenance Instructions.

1.7. COMPATIBILITY WITH OPERATING FLUIDS TO DIN ISO 2943:

- Hydraulic oils H to HLPD to DIN 51524
- Lubrication oils to DIN 51517, APJ, ACEA, DIN 51515, ISO 6743
- Compressor oils to DIN 51506
- Rapidly biodegradable operating fluids to VDMA 24568 HETG, HEES, HEPG
- Non-flam operating fluids HFC and HFD
- Operating fluids with high water content (>50% water content) on request

For further details on filter elements:

Brochure no.: E 7.200../.

2. GENERAL

Mounting

Manifold mounted rear flanged

Temperature range

-10 °C to +100 °C
(-30 °C to -10 °C: $\frac{p_{max}}{2}$ only is permissible)

Pressure setting of the clogging indicator

$\Delta p_a = 5 \text{ bar} - 0.5 \text{ bar}$
Other pressure settings on request

Cracking pressure of bypass valve

$\Delta p_o = 6 \text{ bar} + 0.6 \text{ bar}$
Other cracking settings on request
(only for DF...MA/DF...QE)

Circuit diagram

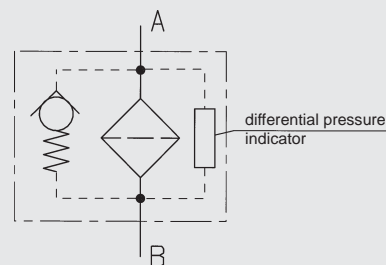

3. MODEL CODE

(also order example)

3.1. COMPLETE FILTER

DF BN/HC 160 MHE 10 D 1 . X -L24

Filter type _____

Filter material _____

BN/HC Betamicon® (BN3HC)
BH/HC Betamicon® (BH3HC)
W/HC Stainless steel wire mesh
V Stainless steel fibre

Size: filter and element _____

M A: 60, 110, 140, 160, 240, 280
Q E: 30, 60, 110, 140, 160, 240, 280, 330, 500, 660, 990, 1320
MHA: 160, 240, 280
MHE: 330, 500, 660, 990, 1320

Operating pressure _____

M: 250 bar
Q: 315 bar

Application _____

No details: 10⁶ cycles
H: high dynamic for 10⁸ cycles (only for 250 bar operating pressure)

Type of connection / Connection size _____

A: 2 mounting holes
E: 4 mounting holes

Filtration rating in µm _____

BN3HC, BH3HC, V : 3, 5, 10, 20
W/HC : 25, 50, 100, 200

Type of clogging indicator _____

Y = plastic blanking plug in indicator port
A = steel blanking plug in indicator port
B = visual indicator
C = electrical indicator
D = combined visual/electrical indicator

for other clogging indicators,
see brochure no. E 7.050../..

Type code _____

1 version with 1-piece bowl: up to size 660
2 version with 2-piece bowl: size 660-1320

Modification number _____

X the latest version is always supplied

Supplementary details _____

V FPM seals, filter suitable for rapidly biodegradable oils and phosphate ester (HFD-R)
W suitable for oil-water emulsions HFA, HFC
(only necessary when using a clogging indicator and/or V or W/HC elements)
L... light with corresponding voltage (24V, 48V, 110V, 220V)] only on clogging
LED 2 light-emitting diodes up to 24 volt] indicators type D
B. special cracking pressure of bypass (B3 = 3 bar, B6 = 6 bar; only on DF...M A / DF...Q E)
SO184 pressure release / oil drain plug (up to size 280)
OAI outlet above inlet (only for DF 160, 240, 280 Q E)
SO348 for operating pressure $p_{\max} \leq 210$ bar (see point 4.)

3.2. REPLACEMENT ELEMENT

0330 D 010 BN3HC /-V

Size
 0030, 0060, 0110, 0140, 0160, 0240
 0280, 0330, 0500, 0660, 0990, 1320

Type
 D

Filtration rating in μm
 BN3HC, BH3HC, V : 3, 5, 10, 20
 W/HC : 25, 50, 100, 200

Filter material
 BN3HC, BH3HC, V, W/HC

Supplementary details
 V = FPM seals, filter suitable for rapidly biodegradable oils and phosphate ester (HFD-R)
 W = element suitable for oil-water emulsions HFA, HFC (only necessary for V and W/HC elements)

4. FILTER SPECIFICATIONS

Version	M A	Q E	MHA	MHE
P_{max}	250 bar	315 bar	250 bar	
Cycles	10 ⁶		10 ⁸	
Temperature range	-30 °C to 100 °C (see point 2)			
Pressure setting of the clogging indicator	5 bar (Standard)			
Type of clogging indicator	Standard: VD For S0 348: VM			
Material of filter head	GGG 40 (SG iron)		ADI	
Material of filter bowl	steel			
Cracking pressure of bypass	6 bar		no bypass valve	
Sizes	60-280	30-1320	160-280	330-1320

5. FILTER CALCULATION/SIZING

The total pressure drop of a filter at a certain flow rate is the sum of the housing Δp and the element Δp .

The pressure drop can either be determined with the aid of our Filter Sizing Program, which is available free of charge, or by using the following graphs.

5.1. ΔP -Q HOUSING GRAPHS TO ISO 3968

The housing graphs apply to mineral oil with a density of 0.86 kg/dm^3 and a kinematic viscosity of $30 \text{ mm}^2/\text{s}$. In this case, the differential pressure changes proportionally to the density.

DF 60/110/140 M A

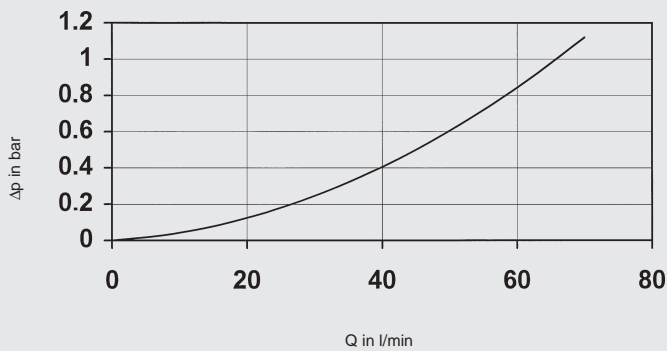

DF 60/110/140 Q E

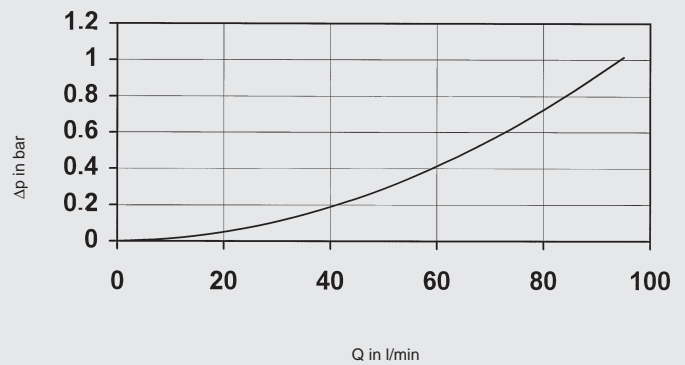

DF 160/240/280 M A / MHA

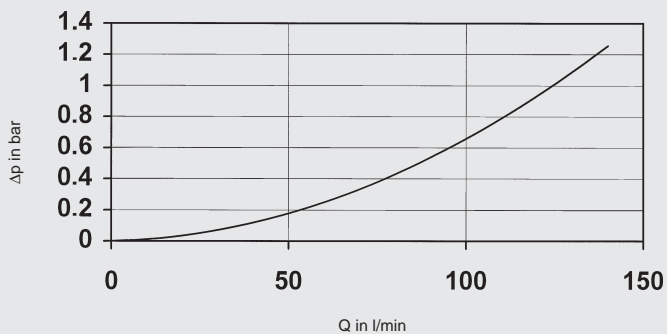

DF 160/240/280 Q E (also /-OAI)

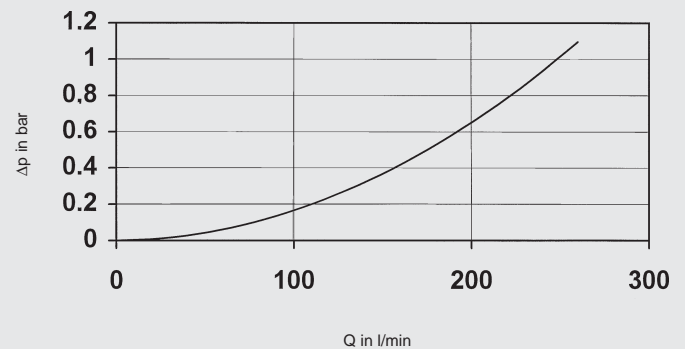

DF 30 Q E

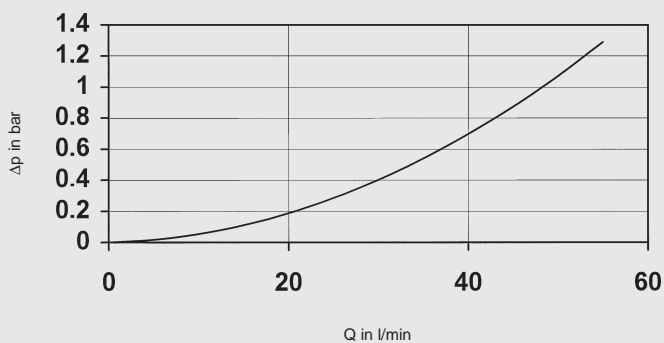

DF 330/500/660/990/1320 Q E / MHE

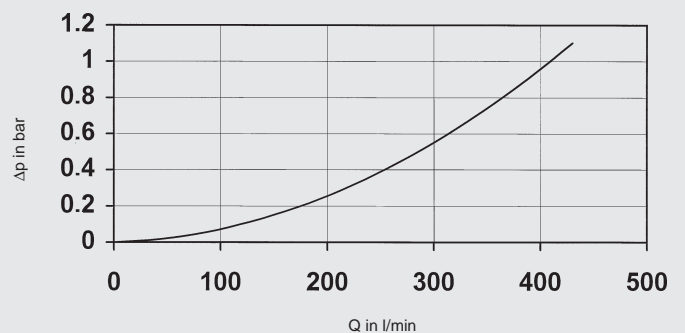

5.2. ΔP -Q GRAPHS - FILTER ELEMENTS

The element graphs apply to mineral oil with a kinematic viscosity of 30 mm²/s. The pressure drop changes proportionally to the change in viscosity (see Example 5.3.).

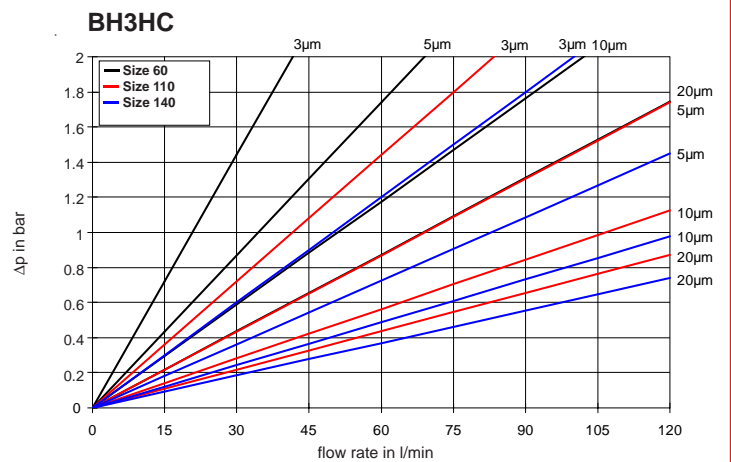
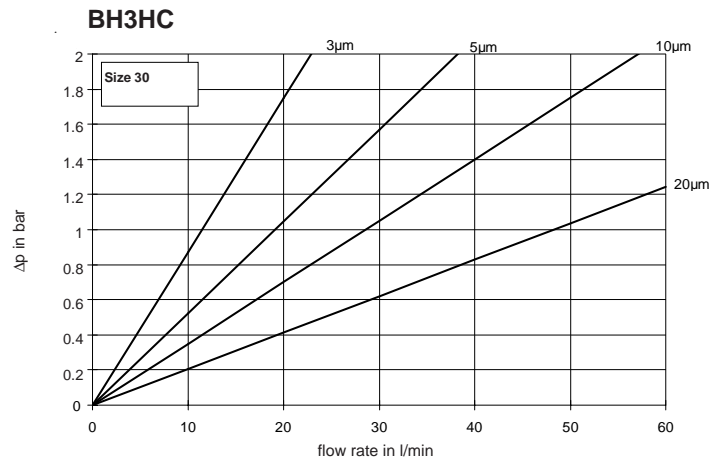
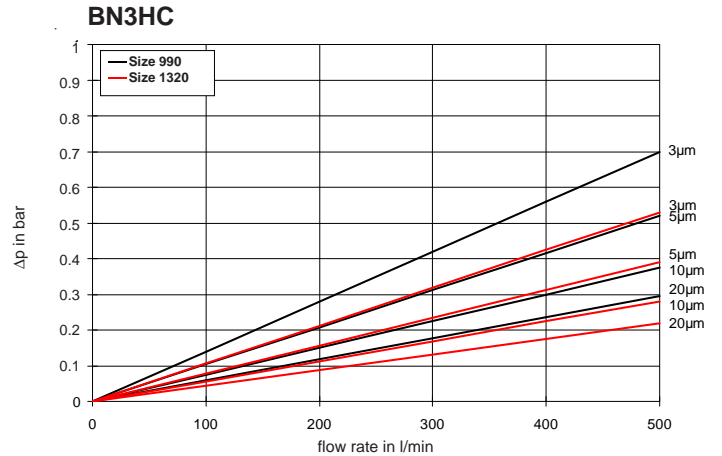
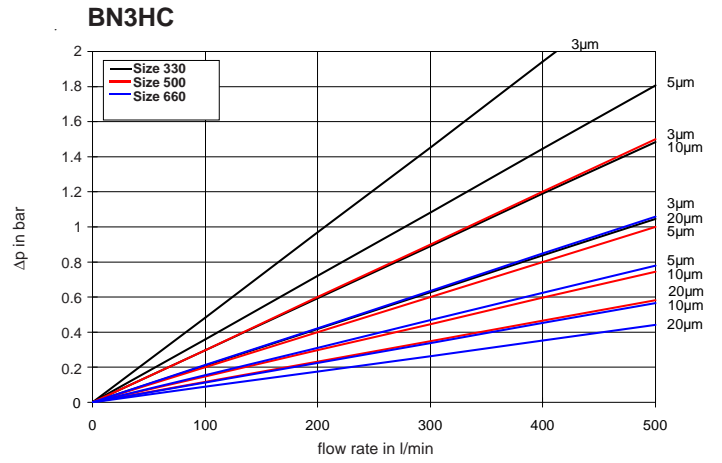
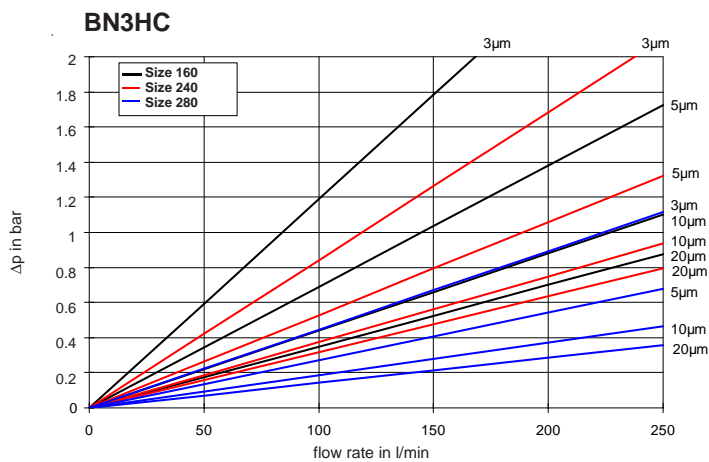
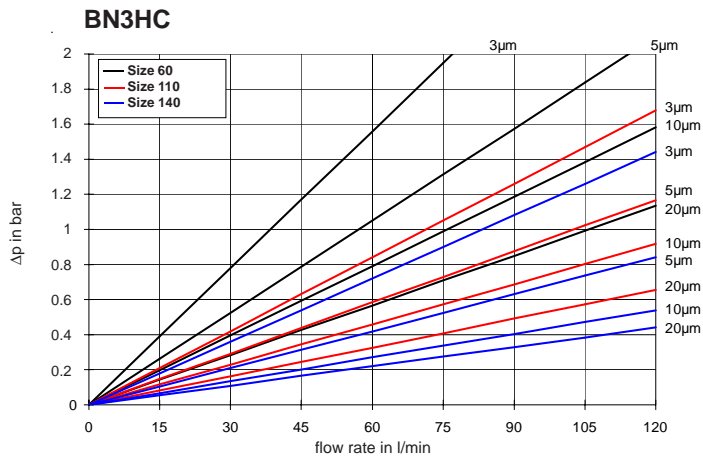
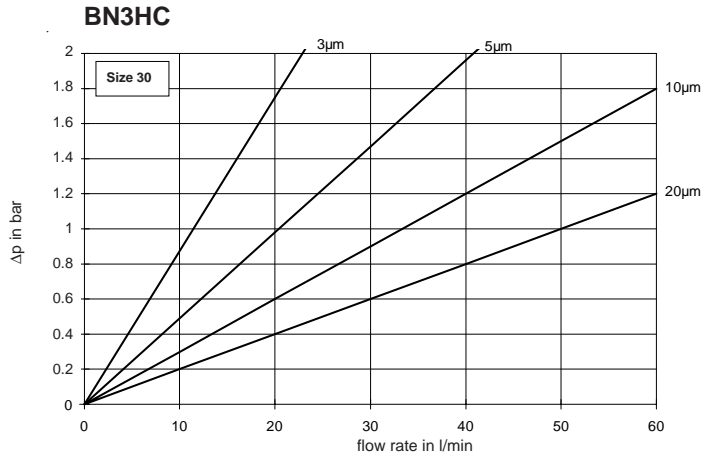

BH3HC

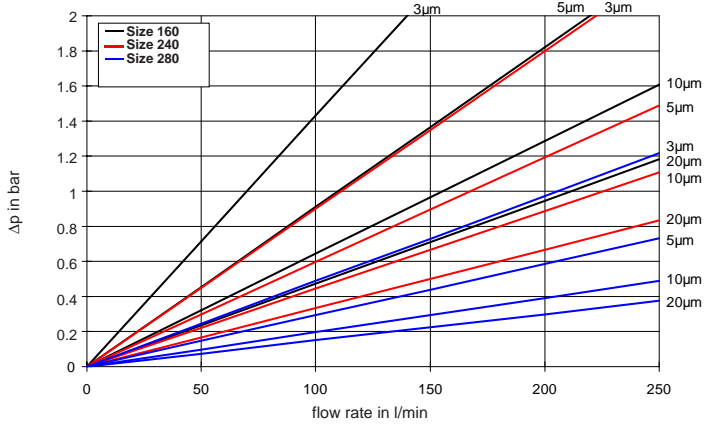

BH3HC

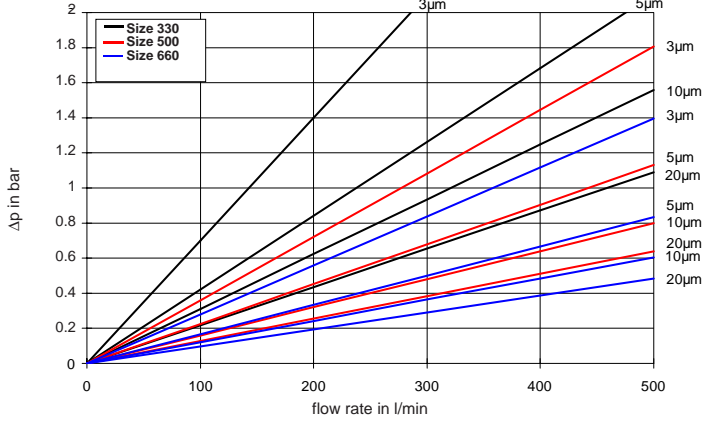

BH3HC

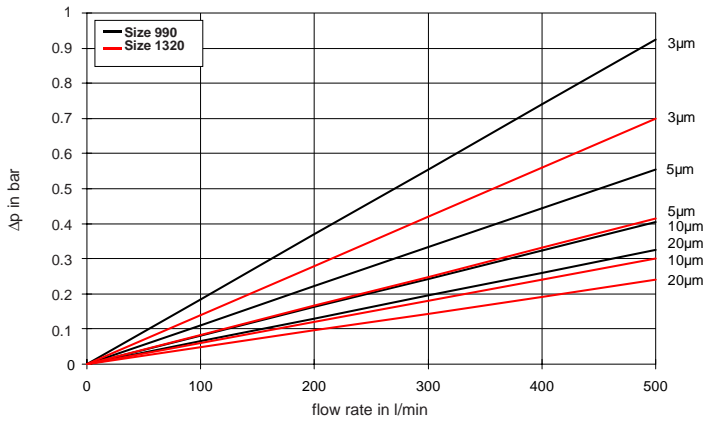

V

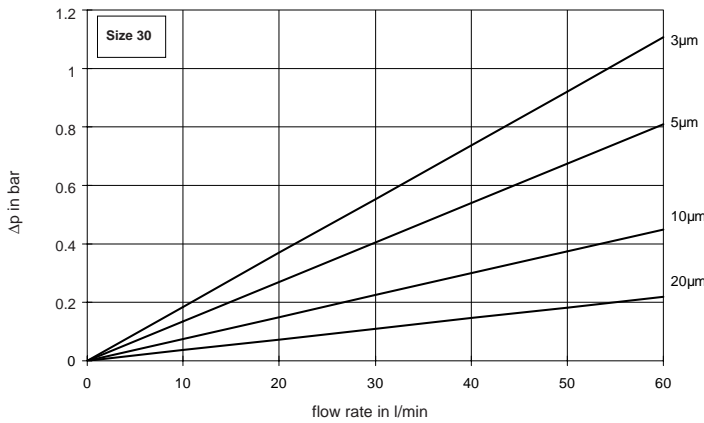

V

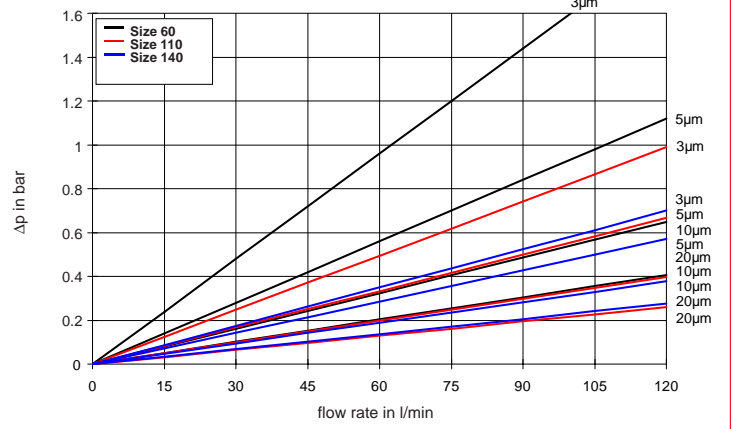

V

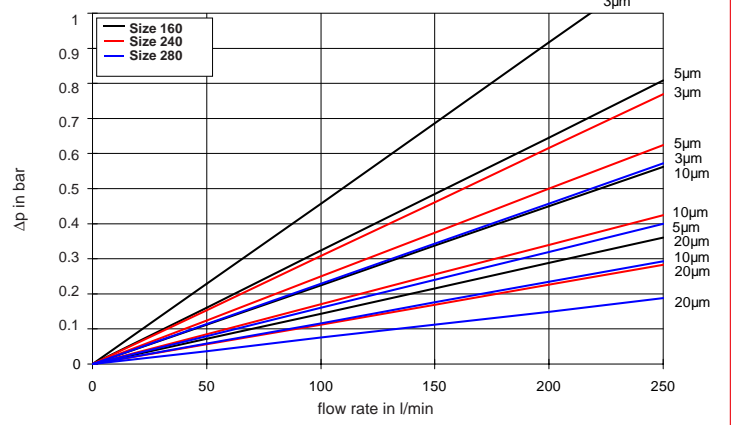

V

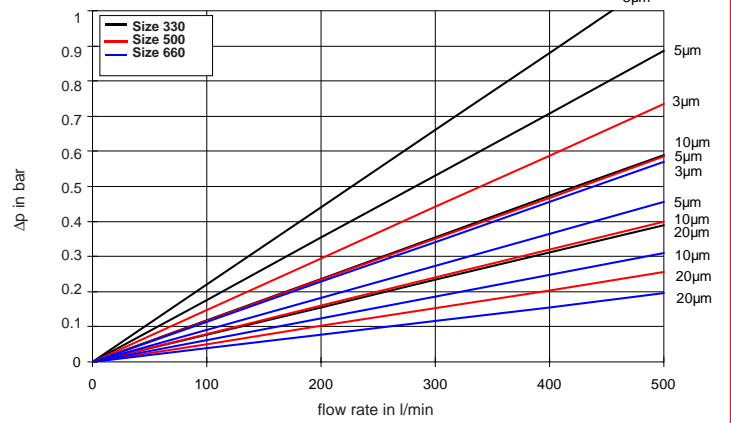

V

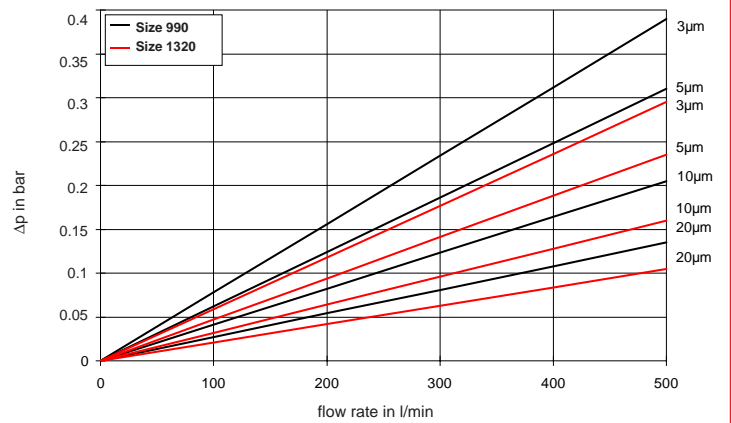

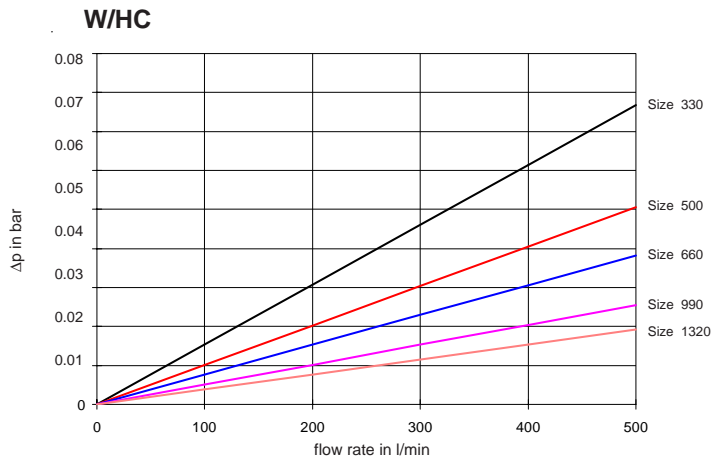
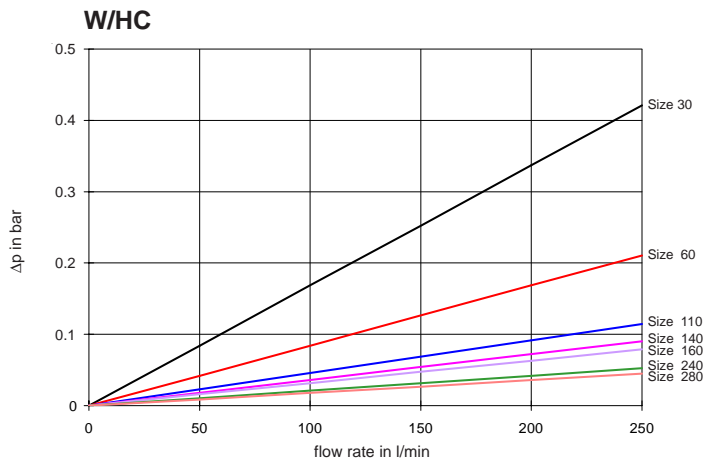

5.3. EXAMPLE

General

$$\Delta p_{\text{total}} = \Delta p_{\text{housing}} + \Delta p_{\text{element}} \cdot \frac{\text{viscosity (mm}^2/\text{s)}}{30 \text{ mm}^2/\text{s}}$$

$\Delta p_{\text{housing}}$ = to be determined from point 5.1.

$\Delta p_{\text{element}}$ = element pressure drop according to point 5.2.

Example

System data: Q = 200 l/min; DF 660 Q E with BN3HC element (10 μm);
viscosity = 68 mm²/s

$$\Rightarrow \Delta p_{\text{housing}} = 0.25 \text{ bar (DF 660 Q E)}$$

$$\Delta p_{\text{element}} = 0.25 \text{ bar} \cdot \frac{68 \text{ mm}^2/\text{s}}{30 \text{ mm}^2/\text{s}} = 0.57 \text{ bar}$$

$$\Delta p_{\text{total}} = \Delta p_{\text{housing}} + \Delta p_{\text{element}} = \underline{0.82 \text{ bar}}$$

For ease of calculation, our Filter Sizing Program is available, and can be ordered via our website www.hydac.com.

6. DIMENSIONS

6.1. DF...Q E : SIZES 30-1320
DF...MHE : SIZES 330-1320

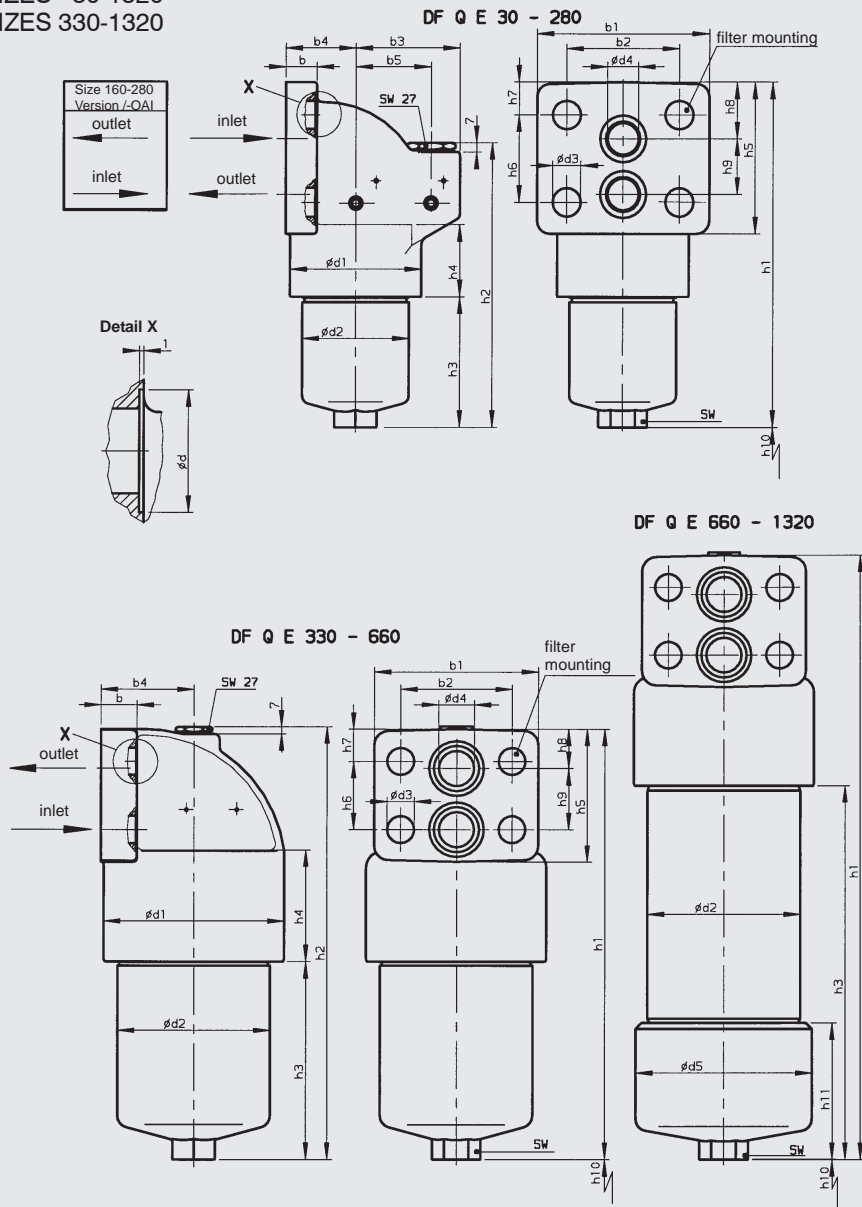

Type	b	b1	b2	b3	b4	b5	d	d1	d2	d3	d4	d5	h1	h2	h3	h4	h5	h6	h7	h8	h9	h10	h11	SW	O-ring ¹⁾	Weight incl. element in kg
30	18	80	57	56	37	38	20	67	52	13	14	-	197	176	78	48	76	45	15.5	30.5	28	75	-	24	18 x 2.5	2.9
60	20	110	72	66	45	48	26	84	68	18	20	-	217	181	83	45.5	94	55	19.5	34.5	35	75	-	27	24 x 3	5.2
110	20	110	72	66	45	48	26	84	68	18	20	-	284	248	150	45.5	94	55	19.5	34.5	35	75	-	27	24 x 3	6.1
140	20	110	72	66	45	48	26	84	68	18	20	-	328	292	194	45.5	94	55	19.5	34.5	35	75	-	27	24 x 3	6.7
160	30	140	95	89	59	69	32	116	95	22	32	-	280	222	117	61	110	60	25	31	52	85	-	32	40 x 3.5	9.6
240	30	140	95	89	59	69	32	116	95	22	32	-	340	282	177	61	110	60	25	31	52	85	-	32	40 x 3.5	11.6
280	30	140	95	89	59	69	32	116	95	22	32	-	522	464	359	61	110	60	25	31	52	85	-	32	40 x 3.5	15.9
330	30	140	95	-	79.5	-	32	154	130	23	30	-	353	357	157	94	110	58	26	32	52	115	-	36	40 x 3.5	22.9
500	30	140	95	-	79.5	-	32	154	130	23	30	-	446	450	250	94	110	58	26	32	52	115	-	36	40 x 3.5	27.3
660	30	140	95	-	79.5	-	32	154	130	23	30	-	523	527	329	94	110	58	26	32	52	115	-	36	40 x 3.5	30.9
660 ²⁾	30	140	95	-	79.5	-	32	154	132	23	30	152	517	521	321	94	110	58	26	32	52	350	112	36	40 x 3.5	34.1
990 ²⁾	30	140	95	-	79.5	-	32	154	132	23	30	152	673	677	477	94	110	58	26	32	52	500	112	36	40 x 3.5	42.1
1320 ²⁾	30	140	95	-	79.5	-	32	154	132	23	30	152	839	843	643	94	110	58	26	32	52	670	112	36	40 x 3.5	50.3

Version: -/OAI (outlet above inlet)

160	30	140	95	83	84	59	32	116	95	22	32	-	284	239	119	64	110	58	26	31	52	85	-	32	40 x 3.5	10.7
240	30	140	95	83	84	59	32	116	95	22	32	-	344	299	179	64	110	58	26	31	52	85	-	32	40 x 3.5	12.7
280	30	140	95	83	84	59	32	116	95	22	32	-	526	481	361	64	110	58	26	31	52	85	-	32	40 x 3.5	17.0

¹⁾ supplied

²⁾ 2-piece bowl version

6.2. DF...M A : SIZES 60-280
DF...MHA: SIZES 160-280

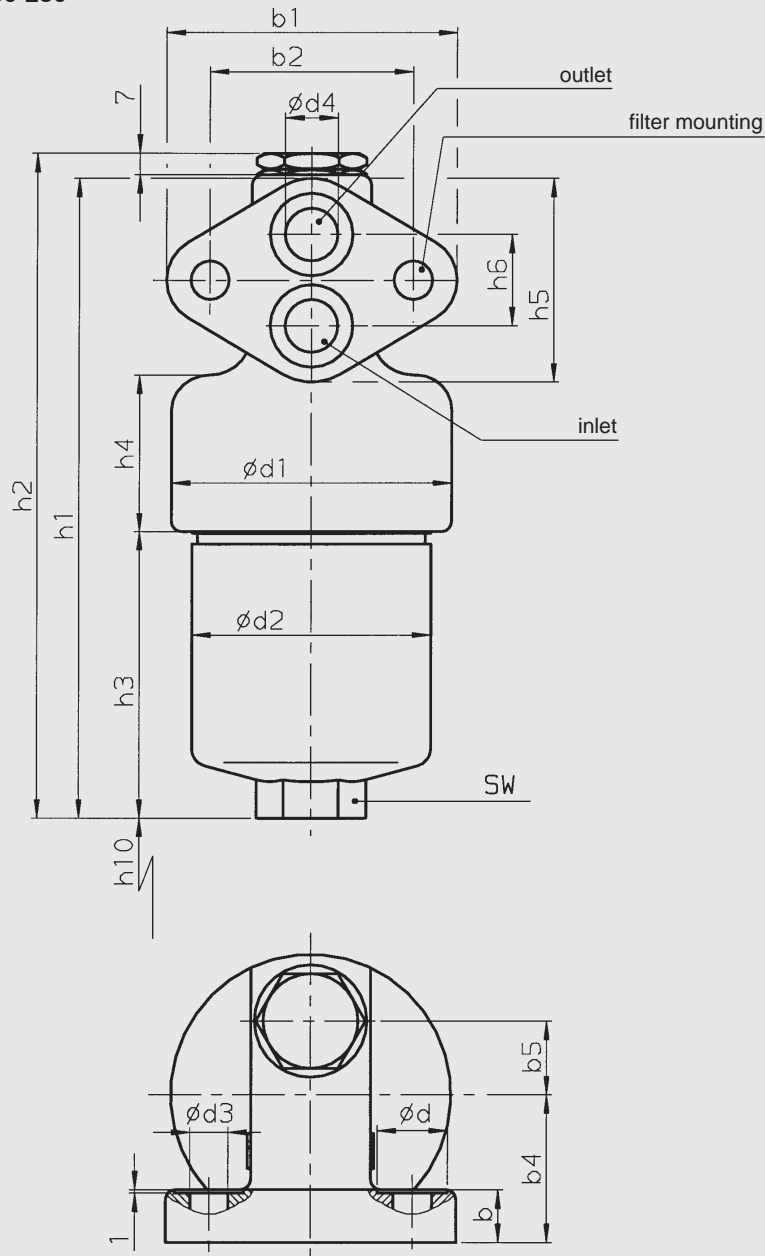

Type	b	b1	b2	b4	b5	d	d1	d2	d3	d4	h1	h2	h3	h4	h5	h6	h10	SW	O-ring ¹⁾	Weight incl. element in kg
60	15	83	58	42	21	20	80	68	11	15	185	192	83	45	58	26	75	27	19 x 2.5	3.5
110	15	83	58	42	21	20	80	68	11	15	252.5	259.5	150.5	45	58	26	75	27	19 x 2.5	4.4
140	15	83	58	42	21	20	80	68	11	15	296	303	194	45	58	26	75	27	19 x 2.5	5.0
160	20	83	58	60	26	20	116	95	13.5	15	232	239	107	79	58	26	85	32	19 x 2.5	8.1
240	20	83	58	60	26	20	116	95	13.5	15	292	299	167	79	58	26	85	32	19 x 2.5	9.6
280	20	83	58	60	26	20	116	95	13.5	15	474	481	349	79	58	26	85	32	19 x 2.5	14.2

¹⁾ supplied

7. NOTE

The information in this brochure relates to the operating conditions and applications described.
For applications or operating conditions not described, please contact the relevant technical department.
Subject to technical modifications.