

HYDAC

INTERNATIONAL

Tank-Top Mounted Return Line Filter RFN

to DIN 24550

Flow rates up to 1,000 l/min

Pressure range up to 10 bar

Material: Aluminium/Polyamide

Return line filters type RFN (standard filters) are designed to be mounted directly on tank tops.

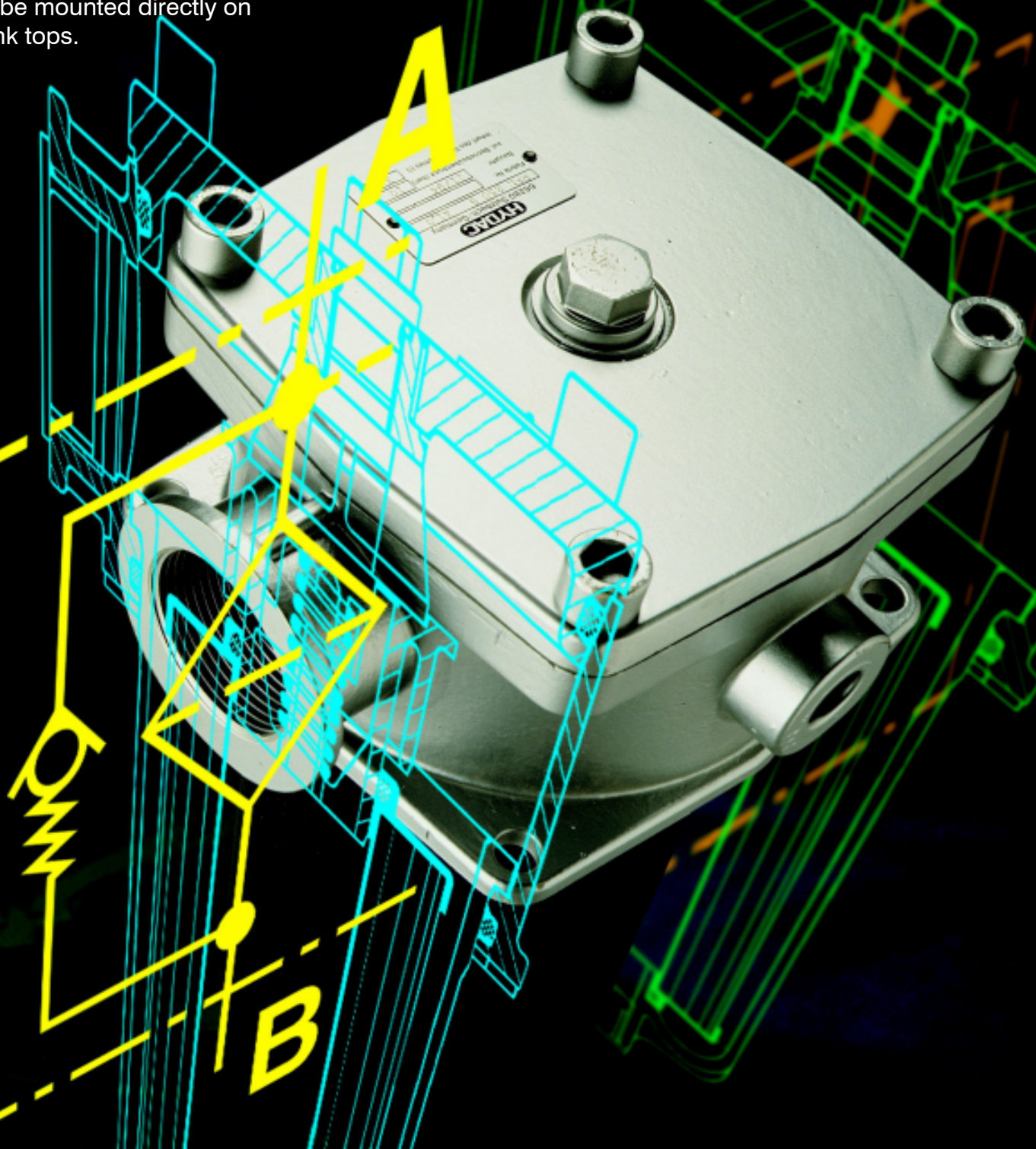

1. TECHNICAL SPECIFICATIONS

1.1. FILTER HOUSING

Construction

The RFN filter consists of a filter head with filter bowl and bolt-on cover plate.

The standard model is supplied with a bypass valve and the connection for a clogging indicator and for tank filling are available as standard.

1.2. FILTER ELEMENTS

Original Hydac filter elements guarantee reliable function and protect hydraulic components and systems which are sensitive to contamination from wear and tear. Performance and quality tests according to international standards guarantee reliable operation of the filter.

HYDAC filters are validated and their quality is continuously monitored according to the following standards:

- DIN ISO 2941:
Verification of collapse / burst resistance
- DIN ISO 2942:
Verification of fabrication integrity and determination of first bubble point
- DIN ISO 2943:
Verification of material compatibility with fluids
- ISO 3724:
Verification of flow fatigue characteristics
- ISO 3968:
Evaluation of pressure drop versus flow characteristics
- ISO 4572/ISO16889:
Multi-pass method for evaluating filtration performance

In addition to guaranteeing retention and flow rate characteristics, the filter elements have excellent structural stability.

The careful construction and mechanically stable support of the filter media guarantee above-average beta value stability and flow fatigue characteristics of the filter elements.

The filter elements are available with the following collapse / burst stability values:

Betamicron® (BN3HC): 25 bar

1.3. CLOGGING INDICATORS (Example)

Type of indicator

VR return line indicator
VMF return line indicator

Pressure setting

2.5 2.5 bar

Indicator type code

LZ visual-mechanical/electrical

Modification number

X the latest version is always supplied

Supplementary details

V Viton
DB with plug to DIN 43651 to Daimler-Benz specification

For further details on clogging indicators, please see:
brochure no.: E 7.050../..

1.4. SEALS

Choice of Perbunan (= NBR) or Viton (= FPM for HFD fluids).

1.5. SPECIAL MODELS AND ACCESSORIES

on request.

1.6. SPARE PARTS

See Original Spare Parts List and Maintenance Instructions.

1.7. COMPATIBILITY WITH OPERATING FLUIDS DIN ISO 2943:

- Hydraulic oils H to HLPD to DIN 51524
- Lubrication oils to DIN 51517, APJ, ACEA, DIN 51515, ISO 6743
- Compressor oils to DIN 51506
- Rapidly biodegradable operating fluids to VDMA 24568 HETG, HEES, HEPG
- Non-flam operating fluids HFC and HFD
- Operating fluids with high water content (>50 water content) on request

For further details on filter elements:

Brochure no.: E 7.200../..

2. GENERAL

Mounting

Tank-top filter

Temperature range

-10 °C ... +100 °C

Pressure setting of the return line clogging indicator

$\Delta p_a = 2.5 \text{ bar } -10\%$

Cracking pressure of bypass valve

$\Delta p_o = 3.5 \text{ bar } +10\%$

Hydraulic symbol RFN

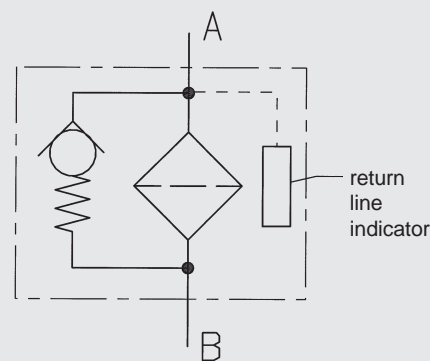

3. MODEL CODE

(also order example)

3.1. COMPLETE FILTER

RFN BN/HC 250 B F 10 A 1 . X /-V

Filter type _____

RFN

Filter material of element _____

BN/HC Betamicron® (BN/HC)

Size / Housing material _____

A/PA: 40, 63, 100, 160, 250, 400, 630, 1000

Operating pressure _____

B = 10 bar

Type of connection / Connection size _____

● to DIN 24550 standard, ○ non-standard

Type	Connection	Filter size							
		40	63	100	160	250	400	630	1000
B	G 1/2	●	○	○					
C	G 3/4	○	●	○					
D	G 1	○	○	●					
E	G 1 1/4				●	○			
F	G 1 1/2				○	●			
M	DN 64						○	●	
N	DN 76								●
Z	According to customer specification								

Filtration rating in µm _____

3, 6, 10, 25

Type of clogging indicator _____

- Y with hole for clogging indicator
- with plastic blanking plug
- A with steel blanking plug
- B with visual indicator
- C with electrical indicator
- D with combined visual/electrical indicator
- E/ES with pressure gauge
- LE with visual-mechanical/electrical indicator
- LZ with visual-mechanical/electrical indicator with 75% and 100% switching contacts

for other
clogging indicators
see brochure
no. E 7.050../..

Type code _____

1

Modification number _____

X the latest version is always supplied

Supplementary details _____

no details = standard (with bypass valve)

- V FPM seals, filter suitable for rapidly biodegradable hydraulic fluids
- L.. light with corresponding voltage (24V, 48V, 110V, 220V)
- LED 2 light-emitting diodes up to 24 volt
- DB LZ indicator with plug to DIN 43651 with three LED's (Daimler-Benz specification)
- CN LZ indicator with plug to DIN 43651 with three LED's (CNOMO specification)
- BO LZ indicator with plug and plug connection to BMW specification (M12x1)
- BO-LED as for BO, but with progressive LED strip
- AV LZ indicator with plug to AUDI specification
- D4C LZ indicator with plug and plug connector to Daimler-Chrysler specification with cold start suppression 30 °C
- GM LZ indicator with „No Element Indicator“
- 30C LZ indicator with temperature limiter (only on type DB)
- T with tank breather filter (only on RFN 40, 63 and 100)
- BAN filling connection G 3/4 (size 160 and above)
- Vxxx outlet extension (xxx = length in mm)

] only on clogging indicators type D

] for circuit diagram see point 3.1.1

3.1.1 Circuit diagram

.../-BO

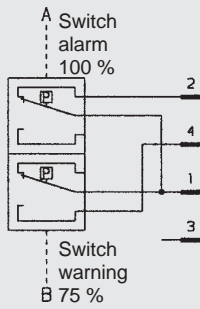

.../-BO-LED

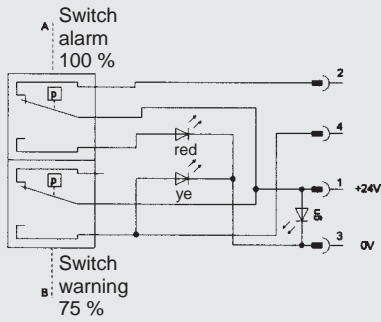

.../-AV

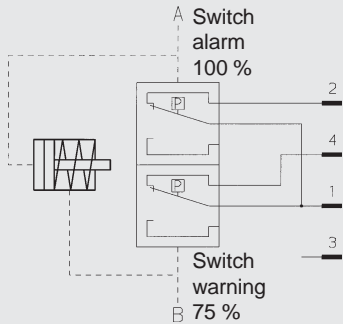

.../-GM

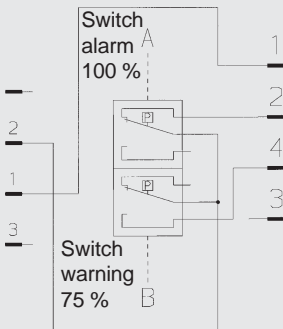

.../-D4C

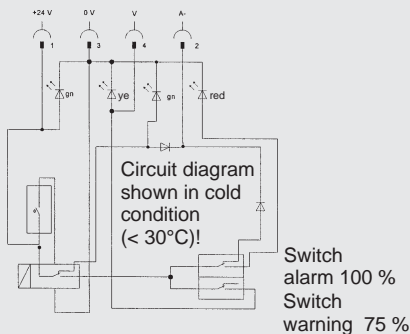

3.2. REPLACEMENT ELEMENT

(also order example)

0250 RN 010 BN/HC /-V

Size _____
0040, 0063, 0100, 0160, 0250, 0400, 0630, 1000

Type _____
RN

Filtration rating in μm _____
3, 6, 10, 25

Filter material _____
BN/HC

Supplementary details _____
V = FPM seals, filter suitable for rapidly biodegradable oils and phosphate ester (HFD-R)

3.2.1 Element specifications

Filter type	Contamination retention capacity in g for BN/HC elements			
	3 μm	6 μm	10 μm	25 μm
40	7.1	8.0	8.9	10.6
63	13.0	14.7	16.3	19.6
100	22.0	24.7	27.5	33.0
160	36.2	40.7	45.3	54.2
250	61.4	69.1	76.8	92.1
400	88.2	99.2	110.2	132.3
630	148.6	167.3	185.8	222.9
1000	151.8	170.8	189.8	227.8

4. FILTER SPECIFICATIONS

Filter type	Element size	Number of elements	Weight [kg] with element
40	0040 RN...	1	1.5
63	0063 RN...	1	1.5
100	0100 RN...	1	1.5
160	0160 RN...	1	3.8
250	0250 RN...	1	3.8
400	0400 RN...	1	9.0
630	0630 RN...	1	9.0
1000	1000 RN...	1	11.0

5. FILTER CALCULATION / SIZING

The total pressure drop of a filter at a certain flow rate is the sum of the housing Δp and the element Δp .

The pressure drop can either be determined with the aid of our Filter Sizing Program, which is available free of charge, or by using the following graphs.

It must be stressed that all of the technical documentation from HYDAC Filtrertechnik always states the pressure drop for the complete filter.

5.1. Δp -Q HOUSING GRAPHS TO ISO 3968

The housing graphs apply to mineral oil with a density of 0.86 kg/dm^3 and a viscosity of $30 \text{ mm}^2/\text{s}$.

In this case, the differential pressure changes proportionally to the density.

RFN 40 / 63 / 100

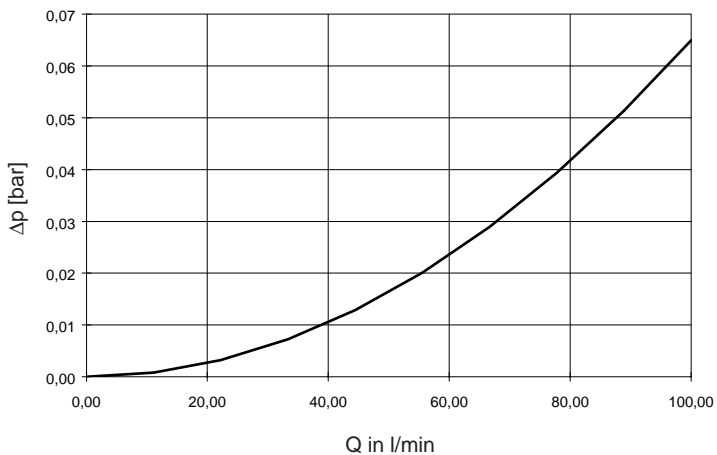

RFN 160 / 250

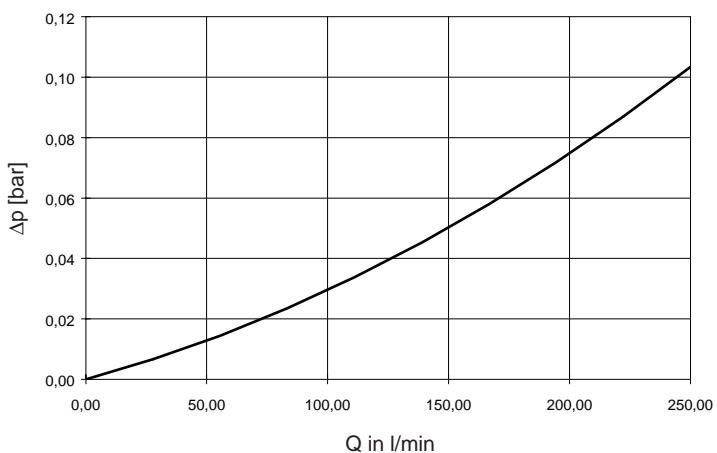

RFN 400 / 630

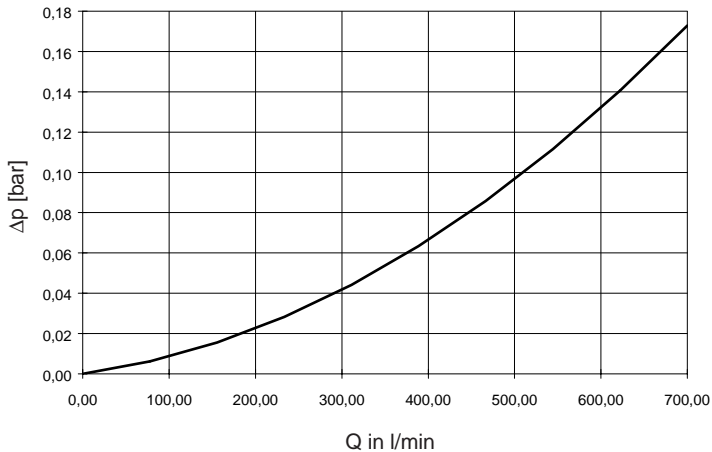

RFN 1000

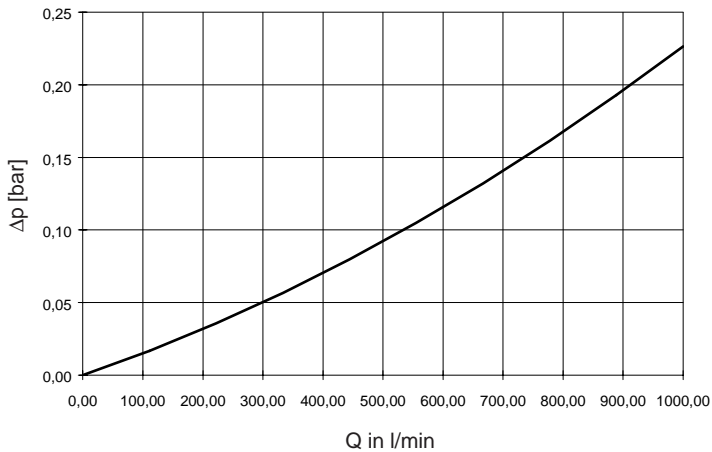

5.2. Δp-Q GRAPHS - FILTER ELEMENTS

The element graphs apply to mineral oil with a kinematic viscosity of 30 mm²/s. The pressure drop changes proportionally to the change in viscosity (see Example 5.3.).

BN/HC: Element size 40/63

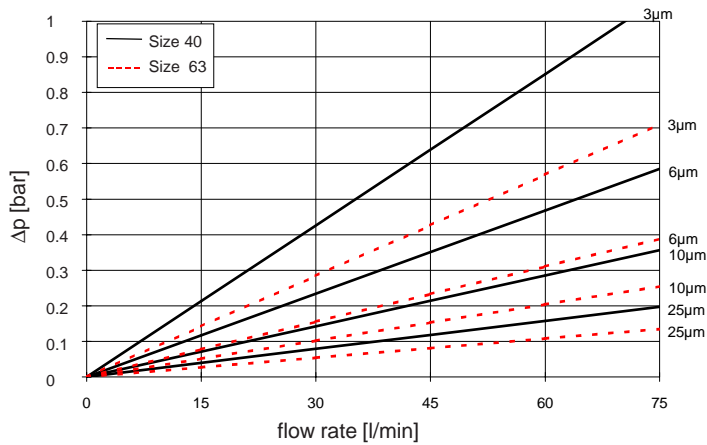

BN/HC: Element size 100/160

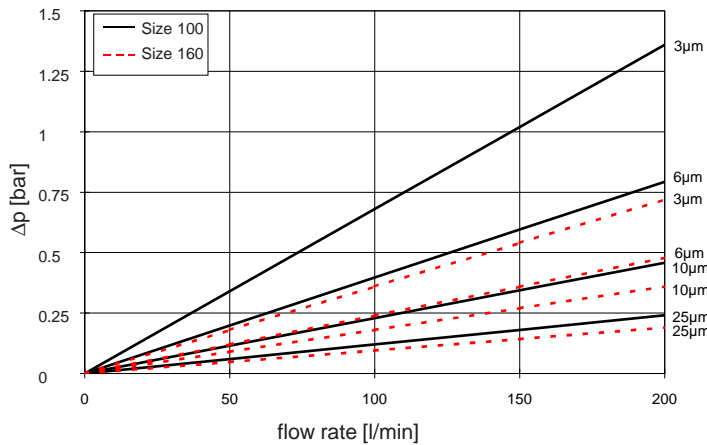

BN/HC: Element size 250/400

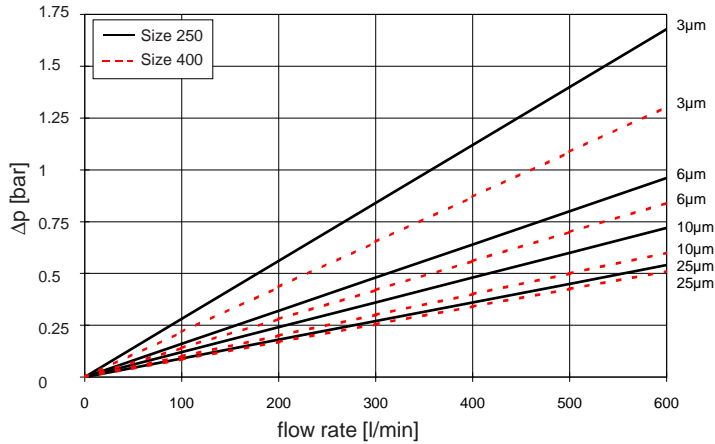

BN/HC: Element size 630/1000

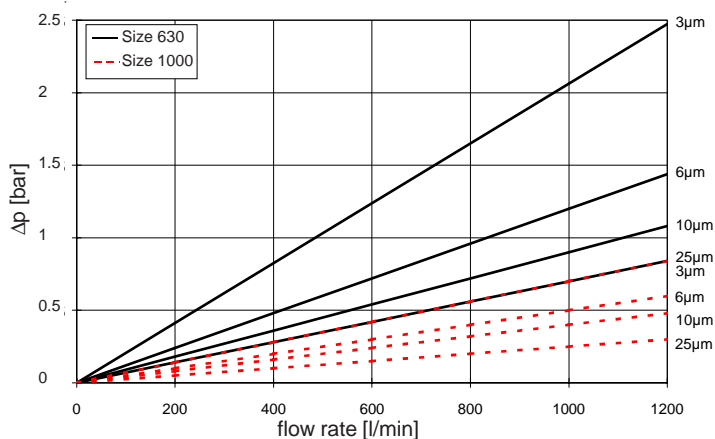

5.3. EXAMPLE

General:

$$\Delta p_{\text{total}} = \Delta p_{\text{housing}} + \Delta p_{\text{element}} \times \frac{\text{viscosity (mm}^2/\text{s)}}{30 \text{ mm}^2/\text{s}}$$

$\Delta p_{\text{housing}}$ = to be determined from point 5.1.

$\Delta p_{\text{element}}$ = element pressure drop at flow rate Q and viscosity 30 mm²/s according to point 5.2.

Example:

System data:

RFN 250 with BN/HC element (10 μm);

viscosity = 68 mm²/s (ISO VG 68 at 40 °C);

Q = 175 l/min;

$$\Rightarrow \Delta p_{\text{housing}} = 0.10 \text{ bar (RFN 250)}$$

$$\Delta p_{\text{element}} = 0.17$$

$$\Delta p_{\text{total}} = 0.10 \text{ bar} + 0.17 \times \frac{68 \text{ mm}^2/\text{s}}{30 \text{ mm}^2/\text{s}} = 0.48 \text{ bar}$$

For ease of calculation, our FSP Filter Sizing Program is available and can be downloaded from our website www.hydac.com.

6.2. RFN 160, 250

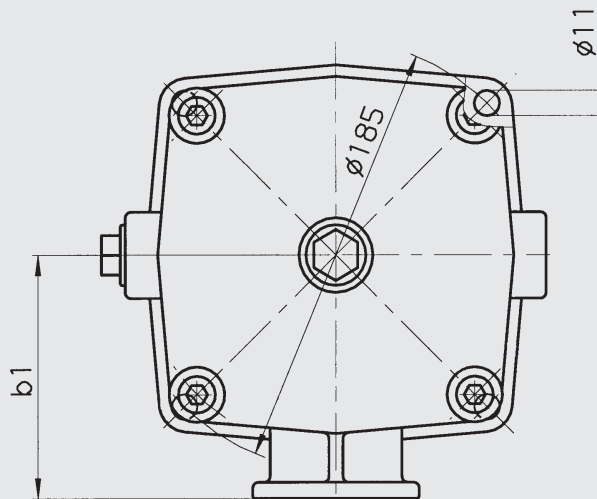
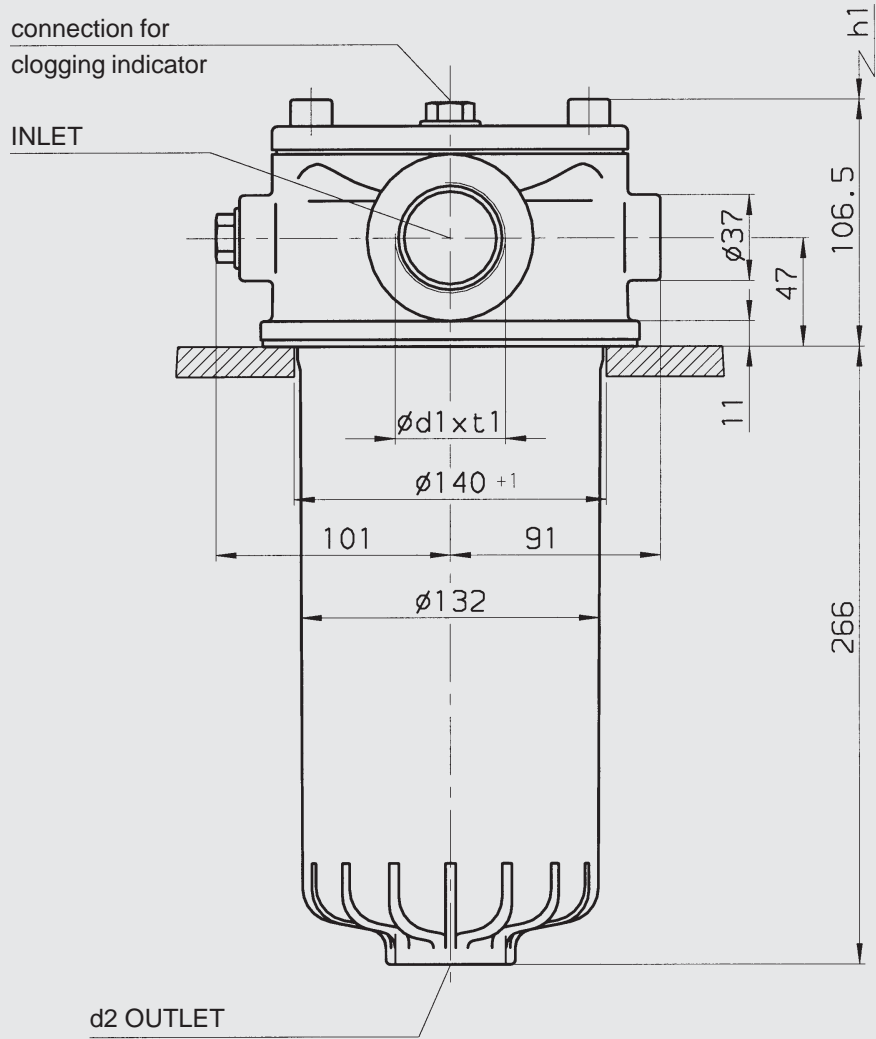

Typ	d1 Inlet	d2 Outlet	b1	h1	t1+2
RFN 160	G 1 1/4	G 1 1/2	141	210	20
RFN 160	G 1 1/2	G 1 1/2	105		22
RFN 250	G 1 1/4	G 1 1/2	141	300	20
RFN 250	G 1 1/2	G 1 1/2	105		22

6.3. RFN 400, 630

connection for
clogging indicator

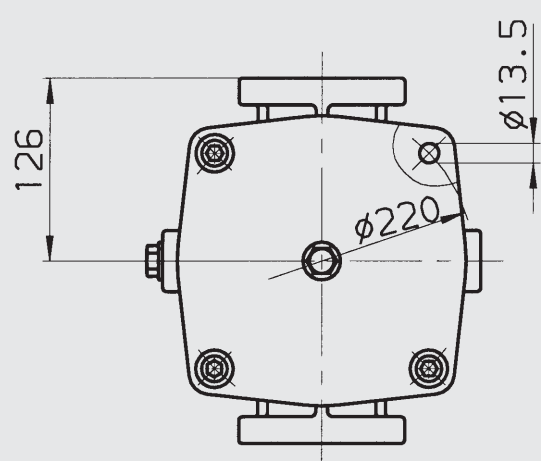
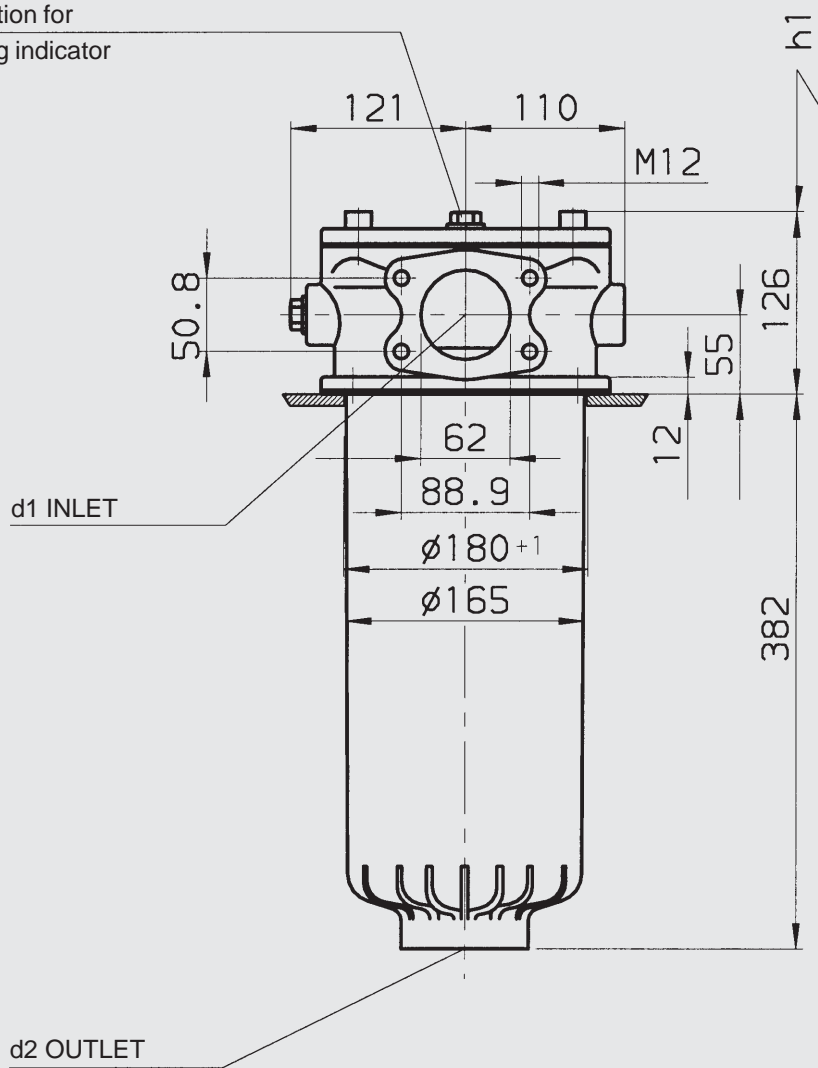

Typ	d1 Inlet	d2 Outlet	h1 min.
RFN 400	DN 64	G 2 1/2	270
RFN 630	DN 64	G 2 1/2	420

6.4. RFN 1000

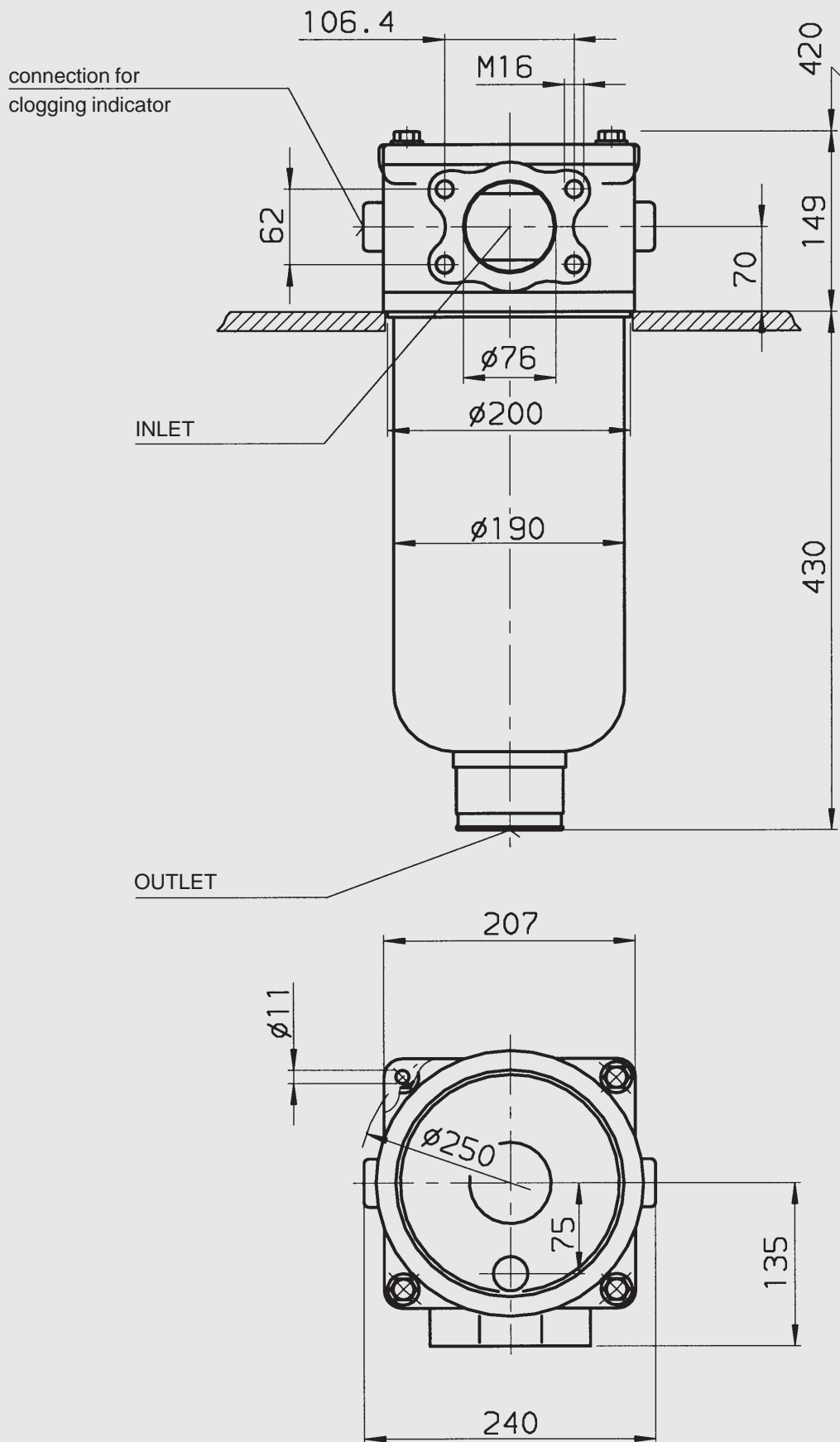

7. NOTE

The information in this brochure relates to the operating conditions and applications described. For applications or operating conditions not described, please contact the relevant technical department. Subject to technical modifications.

NOTES: