

Diaphragm Accumulators

1. DESCRIPTION

1.1. FUNCTION

Fluids are practically incompressible and cannot therefore store pressure energy.

The compressibility of a gas is utilised in hydro-pneumatic accumulators for storing fluids. HYDAC diaphragm accumulators are based on this principle, using nitrogen as the compressible medium.

The diaphragm accumulator consists of a fluid section and a gas section with the diaphragm acting as a gas-proof screen.

The fluid section is connected with the hydraulic circuit, so that the diaphragm accumulator draws in fluid when pressure increases and the gas is compressed. When the pressure drops, the compressed gas expands and forces the stored fluid into the circuit.

At the base of the diaphragm is a prevulcanised valve poppet. This shuts off the hydraulic outlet when the accumulator is completely empty and thus prevents damage to the diaphragm.

NOTE:

HYDAC diaphragm accumulators when fitted with a HYDAC Safety & Shut-off Block comply with the regulations of the Pressure Equipment Directive PED 97/23/EC and the German industrial safety regulations Betr.VO.

Please refer to brochure "Safety & Shut-Off Block SAF/DSV" no. 3.551../..



1.2. CONSTRUCTION

HYDAC diaphragm accumulators are available in two versions.

1.2.1 Weld type

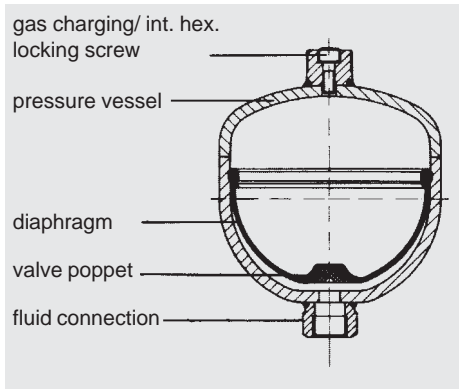

This consists of:

- Welded pressure vessel, rechargeable on the gas side or, alternatively, completely sealed. Fluid connection available in various types.
- Flexible diaphragm to separate the fluid and gas sections.
- Valve poppet set into the base of the diaphragm

1.2.2 Screw type

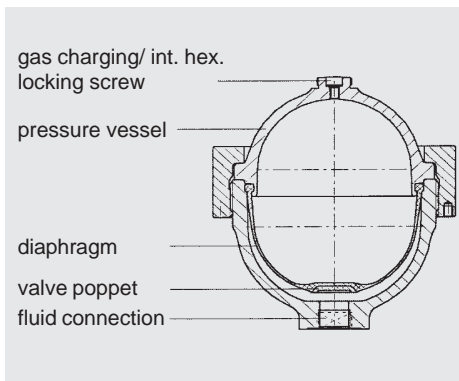

This consists of:

- Forged upper section with gas charging connection.
- Forged lower section with fluid connection.
- Exchangeable flexible diaphragm to separate the gas and fluid.
- Vulcanized valve poppet set into the base of the diaphragm
- Lock nut to hold the upper and lower sections of the accumulator together.

1.2.3 Diaphragm materials

The diaphragms are available in the following elastomers:

- NBR (acrylonitrile butadiene rubber, PERBUNAN)
- IIR (butyl rubber)
- FKM (fluoro rubber, VITON®)
- ECO (ethylene oxide epichlorohydrin rubber).

The material used depends on the respective operating medium and temperature.

1.2.4 Corrosion protection

For use with chemically aggressive fluids the accumulator can be supplied with corrosion protection, such as plastic coating or a galvanic or chemical surface protection. If this is insufficient, then stainless steel accumulators are available in nearly all types.

The options detailed in points 1.2.3. and 1.2.4. allow these accumulators to be used with mineral oils, non-flam fluids and numerous chemically aggressive fluids.

1.3. MOUNTING POSITION

Optional; however, if there is a risk of contamination collecting, a vertical position is preferable, with the fluid connection at the bottom.

1.4. TYPE OF MOUNTING

Accumulators up to 2 l can be screwed directly inline.

- Where strong vibrations are expected, the accumulator must be secured to prevent it working loose. For weld type accumulators we recommend HYDAC support clamps. For screw type accumulators with lock nut, a suitable support console can be found in our brochure "Supports for Hydraulic Accumulators" no. 3.502.
- Additional male threads on the hydraulic connection are available for screwing into mounting holes - see point 3.1.

2. TECHNICAL SPECIFICATIONS

2.1. MODEL CODE

(also order example)

SBO 210 - 2 E1 / 112 U - 210 AK 50

Series _____

Nominal volume (litres) _____

Type ²⁾ _____

E1 = weld type, standard model, rechargeable (M28x1.5)

E2 = weld type, sealed gas connection
with gas pre-charge as requested⁴⁾

E3 = weld type, gas valve M16x1.5,
rechargeable

A6 = screw type (exchangeable diaphragm),
standard model,
rechargeable (M28x1.5)

A3 = screw type (exchangeable diaphragm),
gas valve M16x1.5,
rechargeable

Material code ²⁾ _____

depending on operating medium

112 = standard for mineral oil

Fluid connection _____

1 = carbon steel

3 = stainless steel 1.4571 (316)

4 = carbon steel with surface protection ¹⁾

6 = low temperature steel

Accumulator shell _____

0 = plastic coated

1 = carbon steel

2 = carbon steel with surface protection ^{1) 3)}

4 = stainless steel 1.4571 (316)

6 = low temperature steel

Accumulator diaphragm _____

2 = NBR (acrylonitrile butadiene)

3 = ECO (ethylene oxide epichlorohydrin)

4 = IIR (butyl)

5 = TT-NBR (low temperature NBR)

6 = FKM (fluoro rubber)

7 = others (on request)

Certificate code ²⁾ _____

U = PED 97/23/EC

(for other countries see table 2.2.10)

Permissible operating pressure (bar) _____

Fluid connection ²⁾ form _____

Standard connection = AK or AB

e.g. Form AK = G ³/₄

for SBO 210-2 according to table on page 5

Please state gas pre-charge pressure p₀ at 20 °C ⁴⁾ _____

1) only for screw type

2) not all combinations are possible

3) only parts in contact with the medium

4) only for type E1 or E2, for scheduled orders

2.2. GENERAL

2.2.1 Operating pressure

See tables 3.1. and 3.2.

In some countries the permissible operating pressure can differ from the nominal pressure.

2.2.2 Nominal volume

See tables 3.1. and 3.2.

2.2.3 Effective gas volume

Corresponds to the nominal volume of the diaphragm accumulator.

2.2.4 Effective volume

Volume of fluid available between the operating pressures p_2 and p_1 .

2.2.5 Fluids

Mineral oils, hydraulic oils. Other fluids on request.

2.2.6 Gas charging

Use only nitrogen when charging diaphragm accumulators, never oxygen (**risk of explosion**).

All accumulators are supplied with a protective pre-charge.

Higher gas pre-charge pressures are available on request. (Gas charging screw or sealed gas connection).

2.2.7 Permissible operating temperature

263 K to 353 K
(-10 °C to + 80 °C)
for material code 112.
Others on request.

2.2.8 Permissible pressure ratio

Ratio of max. operating pressure p_2 to gas pre-charge pressure p_0 .

2.2.9 Max. flow rate of the pressure fluid

It is necessary to ensure that a residual fluid volume of approx. 10% of the effective gas volume remains in the accumulator if the max. flow rate given in the tables is to be achieved.

2.2.10 Certificate codes

Hydraulic accumulators which are installed in countries outside Germany are supplied with the test certificates required in that country. The user country must be stated at the time of ordering.

HYDAC pressure vessels can be supplied with virtually any test certificate.

The permissible operating pressure can differ from the nominal pressure.

The following table contains the codes used in the model code for different countries:

Australia	F ¹⁾
Brazil	U ³⁾
Canada	S1 ²⁾
China	A9
CIS	A6
EU member states	U
Hungary	U ³⁾
India	U ³⁾
Japan	P
New Zealand	T
Poland	A4
Romania	U ³⁾
Slovakia	A8
South Africa	U ³⁾
Switzerland	U ³⁾
USA	S
others on request	

¹⁾ = approval required in the individual territories

²⁾ = approval required in the individual provinces

³⁾ = alternative certificates possible

On no account must any welding, soldering or mechanical work be carried out on the accumulator shell. After the hydraulic line has been connected it must be completely vented.

Work on systems with accumulators (repairs, connecting pressure gauges etc) must only be carried out once the pressure and fluid have been released.

Please observe operating instructions!

Note:

Application examples, accumulator sizing and extracts from approvals regulations on hydraulic accumulators can be found in the accumulator overview brochure no. 3.000./...

3. DIMENSIONS

3.1. WELD TYPE ACCUMULATORS – non-exchangeable diaphragm –

Type E1
Form AK

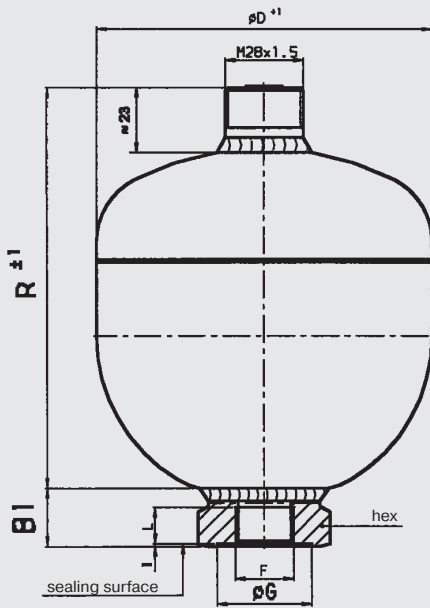

Type E2



Type E3

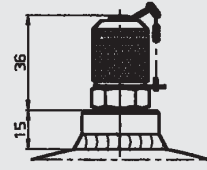

Form AB

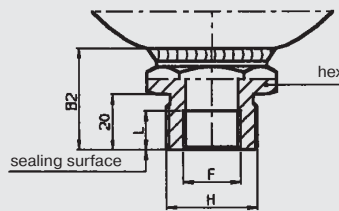

Alternative fluid connection on request

Examples:

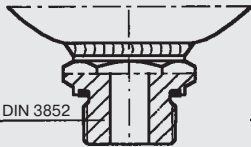

Male threaded connection DIN 3852
Form E
Metric thread or ISO 228

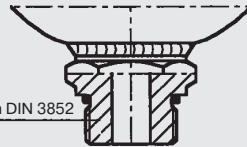

Male threaded connection DIN 3852
Form F
Metric thread or ISO 228

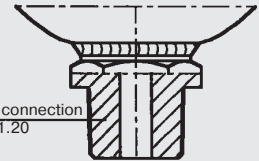

Male threaded connection
NPT to ANSI B1.20

Nom. vol. ¹⁾ (l)	Permiss. press. ratio $p_2 : p_0$	Series	Certificate code U		R (mm)	ØD (mm)	Weight (kg)	Q ²⁾ (l/min)	Standard fluid connection																																						
			Permiss. oper. pressure (bar)						Form AK				Form AB																																		
			Carbon steel	Stainless steel					F (ISO 228)	ØG (mm)	L (mm)	B ₁ (mm)	hex SW	F (ISO 228)	H (DIN 13)	L (mm)	B ₂ (mm)	hex SW																													
0.075	8 : 1	250	250		91	64	0.7	38	G 1/2	34	14	21	30	Not available																																	
0.16		210	210	180	103	74	0.8							Not available																																	
0.32		210	210	160	116	93	1.3							Not available																																	
0.5		210	210		133	105	1.7							Not available																																	
0.6		330	330		151	115	3.3							Not available																																	
0.7		100	100		151	106	1.8							Not available																																	
0.75		210	210	140	147	121	2.8							95	G 1/2	34	14	26	41	G 1/2	M33 x 1.5	14	36	41																							
1		330	330		140	126	4.0															15	42																								
1.4		200	200		160	136	3.6															21	14		36																						
		140	140		173	145	3.9															31	15		42																						
2	100	100	100	190	160	4.0	150	G 3/4	44	16	28	46	G 3/4									M45 x 1.5	16		33	46																					
	210	210		196	167	6.6																			42		42																				
	330	330		183	172	9.2																			28		33																				
2.8	210	210		250	167	8.2																			150		G 3/4	44	16	28	46	G 3/4	M45 x 1.5	16	33	46											
	330	330		238	172	11.0																													42		42										
3.5	250	210		306	170	11.2																													150		G 3/4	44	16	28	46	G 3/4	M45 x 1.5	16	33	46	
	330	330		276	172	13.8								42	42																																
4	50	-	50	295	158	5.0								150	G 3/4	44	16	28	46	G 3/4	M45 x 1.5			16																					33		46

1) others on request
2) max. flow rate

3.2. SCREW TYPE – exchangeable diaphragm –

Type A6 (standard)

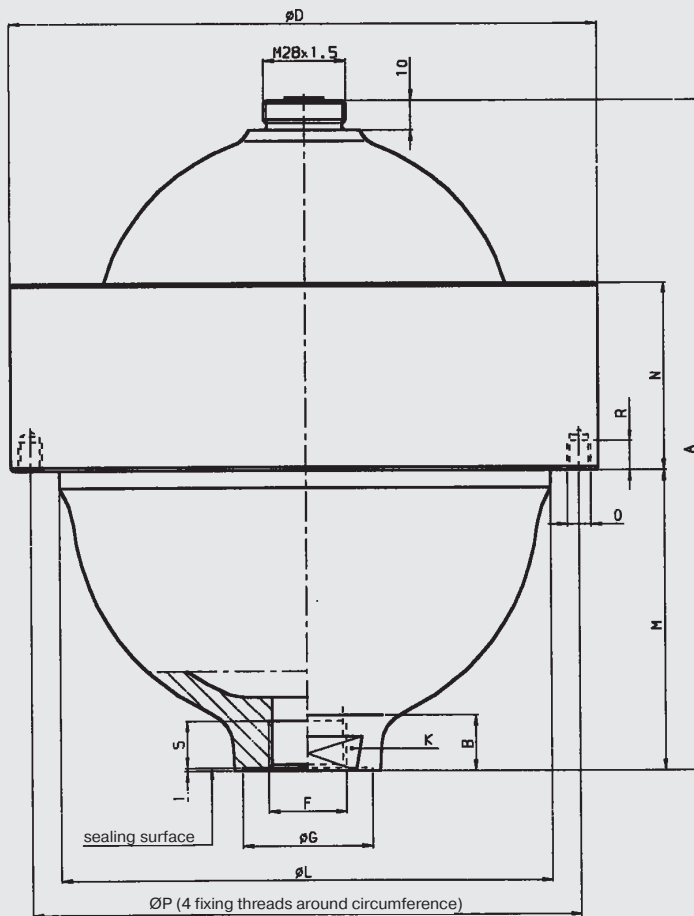

Type A3

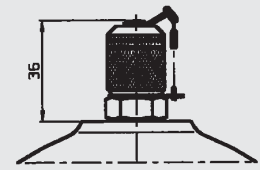

Nom. vol. ¹⁾ (l)	Permiss. press. ratio $P_2 : P_0$	Series	Certificate code U		Weight (kg)	A (mm)	B (mm)	ØD (mm)	ØL (mm)	M (mm)	N (mm)	O	ØP (mm)	R (mm)	Q ²⁾ (l/min)	Standard fluid connection											
			Permiss. oper. pressure (bar)													Form AK											
			Carbon steel	Stainless steel												F ISO 228	S (mm)	ØG (mm)	K SW								
0.1	10 : 1	500	500		1.9	110	30	95	68	53	35	-	-	-	95	G 1/2	14	-	32								
0.25		500	500	350	3.9	128	20	115	92	55	55							-	-	-	-	-	-	-	36		
		750		750	9.0	136	11	153	114	58	63							-	-	-	-	-	-	27	41		
0.6		450	330	250	5.7	170	19	140	115	68	57							M8	160	10	150	G 3/4	16	44	50		
1.3		210	210		8.5	190	8	170	145	78	55	-	-	-	-	-	-									-	32
		400	400		11.2	197	28	199	160	97	65	-	-	-	-	-	-									-	-
2		250	250	180	11.4	227	17	201	168	101	64	-	-	-	-	-	-									-	-
2.8		400	400		22.0	257	30	252	207	106	80	M8	230	10	150	G 3/4	16	44	50								
4		400	400		34.0	262		287	236		90									265							

1) others on request
2) max. flow rate

4. NOTE

For mounting elements (clamps, consoles), please see brochure "Supports for Hydraulic Accumulators", no.: E 3.502. The information in this brochure relates to the operating conditions and applications described. For applications or operating conditions not described, please contact the relevant technical department. Subject to technical modifications.

