

Manifold Mounted Flow Control and Speed Control Valves DVP, DRVP

DVP

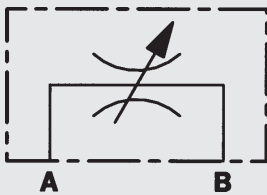

DRVP

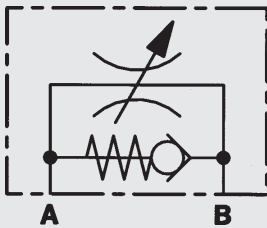

up to 350 bar
up to 300 l/min

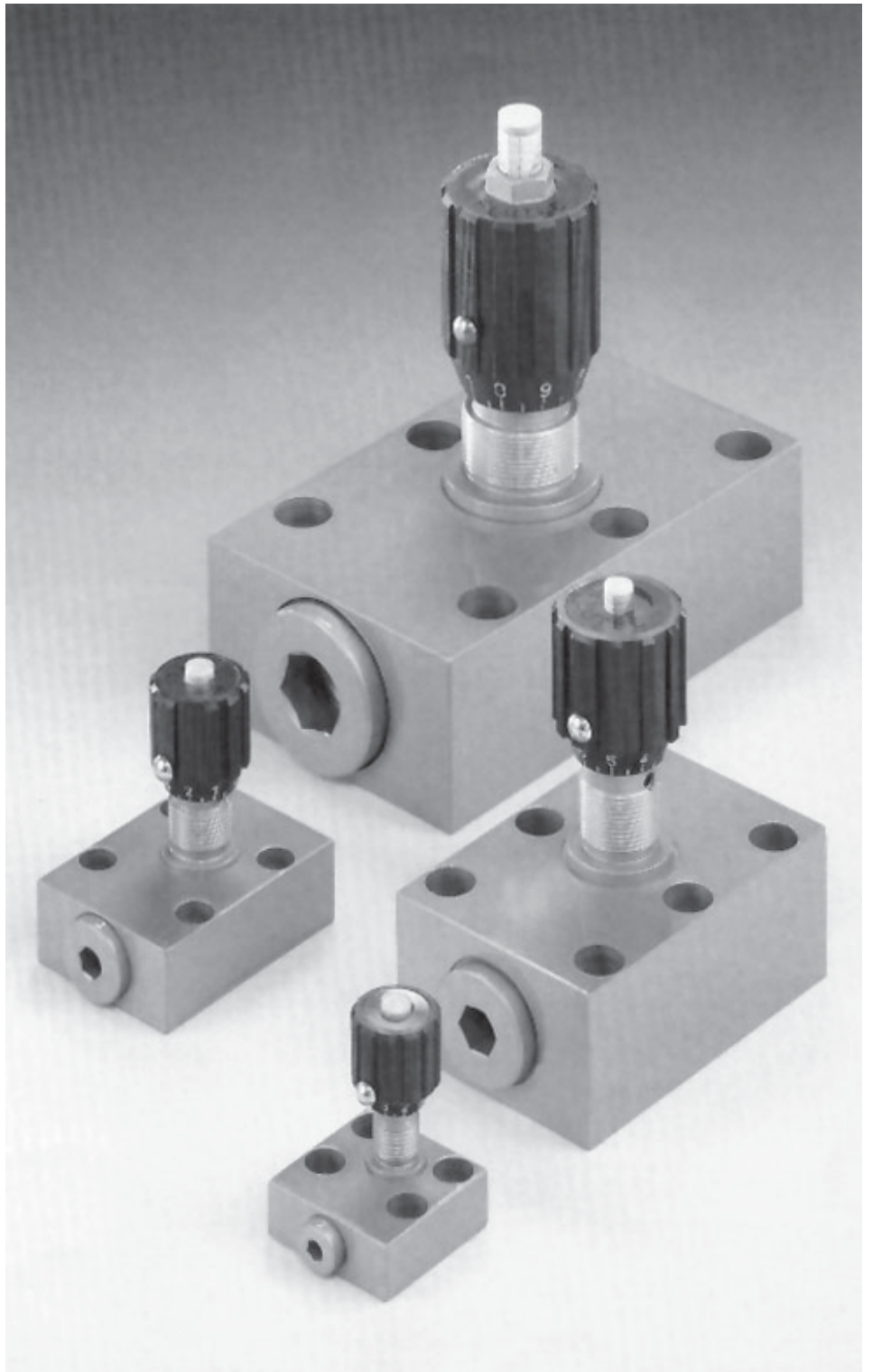

1. DESCRIPTION

1.1. GENERAL

HYDAC flow control and speed control valves DVP/DRVP are, in accordance with DIN-ISO 1219, valves which are designed to control the flow rate in oil hydraulic systems by means of an adjustable constriction of the cross-section.

The flow rate is dependent on pressure differential and viscosity. HYDAC flow control valves DVP have a specially designed throttle mechanism to enable fine adjustment and shut-off of the flow. The flow control and shut-off function works in both directions.

HYDAC speed control valves DRVP allow the same fine flow adjustment. The flow control and shut-off function, however, works in one direction only. Unrestricted flow in the reverse direction is via the built-in check valve.

Further advantages of these valves are:

- Compact construction as manifold mounted valve.
- For mounting onto control blocks or cylinders.
- A high level of safety is achieved through patented spindle safety mechanism.
- A set-screw locks the setting.
- Choice of nine sizes ensures best possible adaptability to the system.
- Mounting position is optional.
- For size 20 and above, valve can be set using a spanner.

DVP

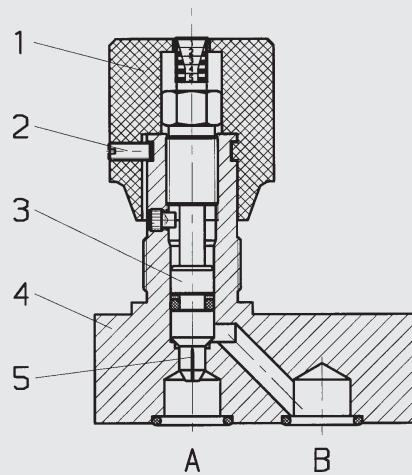

- 1 Control knob
- 2 Set-screw
- 3 Control spindle
- 4 Housing
- 5 Throttle opening

DRVP

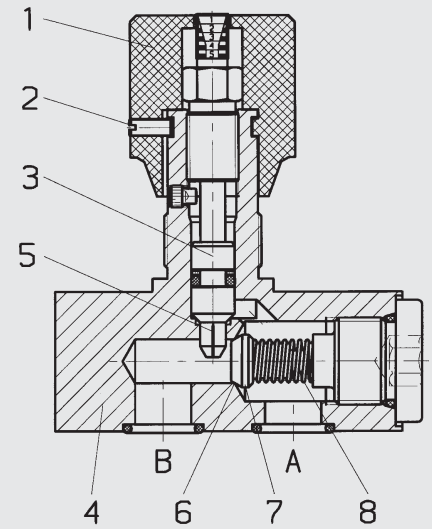

- 1 Control knob
- 2 Set-screw
- 3 Control spindle
- 4 Housing
- 5 Throttle opening
- 6 Valve seat
- 7 Closing cone
- 8 Spring

1.2. FUNCTION

1.2.1 DVP

HYDAC flow control valves consist essentially of a housing, a special control spindle and the control knob.

Starting with the control spindle in the fully closed position when the flow is shut off, the flow rate increases according to the relevant graph (see point 2.2.9) as the number of turns of the control knob is increased.

The control knob with its coloured scale and scale rings permits accurate repetition of the settings. The size of the coloured triangle on the rings indicates the size of the flow area. An increase in the size of the coloured triangle corresponds to an increase in flow area. A set-screw locks the setting. The flow is controlled in both directions.

1.2.2 DRVP

HYDAC speed control valves consist essentially of a housing with built-in valve seat, a hardened and polished closing cone, a spring, the control spindle and the control knob.

The closing cone is pressed onto the valve seat by the spring, thereby shutting off port A from port B. Starting with the control spindle in the fully closed position when the flow is shut off, the flow rate in flow direction A → B increases according to the relevant graph (see point 2.2.9) as the number of turns of the control knob is increased.

The control knob with its coloured scale and scale rings permits accurate repetition of the settings. The size of the coloured triangle on the rings indicates the size of the flow area. An increase in the size of the coloured triangle corresponds to an increase in flow area. A set-screw locks the setting.

The closing cone opens when the pressure across port B is higher than the pressure across port A including the opening pressure produced by the spring force.

1.3. APPLICATIONS

HYDAC flow control and speed control valves DVP/DRVP are used:

- for regulating the speed of loads
 - for system-related damping in hydraulic circuits
 - for pressure-dependent control of flow rates in general
 - to release pressure from accumulator systems
 - as an emergency drain for lowering a load
- Areas of application include, for example:
- Hydraulic units
 - Elevating platforms
 - Mobile hydraulics

1.4. NOTE

On speed control valves the opening pressure of the closing cone increases by the pressure across port A (when control spindle is closed).

2. TECHNICAL SPECIFICATIONS

2.1. GENERAL

2.1.1 Designation and symbol

Flow control valve DVP

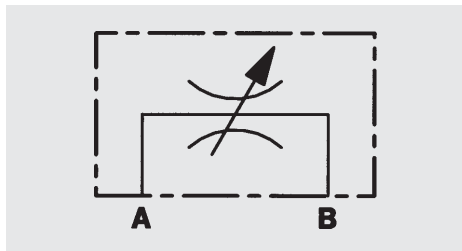

Speed control valve DRVP

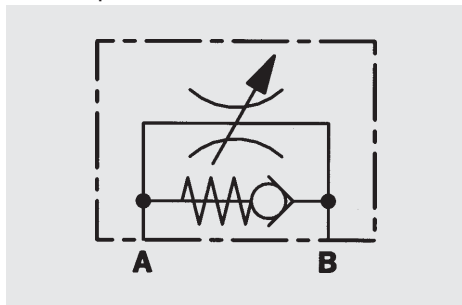

2.1.2 Model code

(also order example)

DVP - 10 - 01 . X

Designation

DVP = flow control valve for manifold mounting

DRVP = speed control valve for manifold mounting

Size

06
08
10
12
16
20
25
30
40

Type

01 = technical specifications as per this brochure

12 = nickel-plated housing, steel spindle with 0.3 mm throttle gap, protective dome nut, adjustment with tool available for DRVP valves size 10, 12, 16

Series

(determined by manufacturer)

Standard models

Stock no.	Model code	Stock no.	Model code
705 351	DVP-06-01.X	705 777	DRVP-06-01.X
705 353	DVP-08-01.X	705 779	DRVP-08-01.X
705 355	DVP-10-01.X	705 781	DRVP-10-01.X
705 357	DVP-12-01.X	705 783	DRVP-12-01.X
705 359	DVP-16-01.X	705 785	DRVP-16-01.X
705 361	DVP-20-01.X	705 787	DRVP-20-01.X
705 363	DVP-25-01.X	705 789	DRVP-25-01.X
705 365	DVP-30-01.X	705 791	DRVP-30-01.X
705 367	DVP-40-01.X	705 792	DRVP-40-01.X

Please quote stock no. when ordering.

Delivery for non-standard models is longer and the price is higher.

2.1.3 Type of construction

DVP: slot type flow control valve with shut-off function

DRVP: slot type flow control valve with shut-off function and built-in check valve

2.1.4 Type of mounting

Manifold connection
(for dimensions, see point 3)
Mounting screws are not supplied with the valve

2.1.5 Mounting position

optional

2.1.6 Weight

See point 3

2.1.7 Direction of flow

DVP: optional

DRVP: from A to B - controlled flow
from B to A - free flow via check valve

2.1.8 Ambient temperature range

min. - 20 °C
max. +80 °C

2.1.9 Materials

Housing:
free-cutting steel, phosphate-plated

Control spindle:
free-cutting steel, phosphate-plated

Control knob:
polyamide

Seals:
FPM and PTFE

2.1.10 Nominal size

NG06
NG08
NG10
NG12
NG16
NG20
NG25
NG30
NG40

2.2. HYDRAULIC DETAILS

2.2.1 Nominal pressure

$p_N = 350$ bar
across all ports

2.2.2 Operating fluid

Mineral oil to DIN 51524 Part 1 and Part 2

2.2.3 Fluid temperature range

min. -20 °C
max. $+80$ °C

2.2.4 Viscosity range

min. 2.8 mm²/s
max. 800 mm²/s

2.2.5 Filtration

Max. permissible contamination level of the operating fluid to ISO 4406 Class 21/19/16 (NAS 1638 Class 10). We therefore recommend a filter with a minimum retention rate of $\beta_{20} \geq 100$.

The fitting of filters and regular replacement of elements guarantees correct functioning, reduces wear and tear and increases the service life.

2.2.6 Type of adjustment

Manually using control knob or on model 12, using Allen key.

2.2.7 Opening pressure of DRVP

$p_O = 0.5$ bar

2.2.8 Flow rate

DVP/DRVP-06...Q = 20 l/min
DVP/DRVP-08...Q = 50 l/min
DVP/DRVP-10...Q = 60 l/min
DVP/DRVP-12...Q = 90 l/min
DVP/DRVP-16...Q = 180 l/min
DVP/DRVP-20...Q = 300 l/min
DVP/DRVP-25...Q = 300 l/min
DVP/DRVP-30...Q = 300 l/min
DVP/DRVP-40...Q = 300 l/min

2.2.9 Pressure drops, dependent on flow rate

DVP

Flow direction from A to B and from B to A

DRVP

Flow direction from A to B

Pressure differential Δp depending on flow rate Q at constant flow setting measured at

$\nu = 54$ mm²/s and $t_{oil} = 36$ °C.

DVP/DRVP-06-01.X

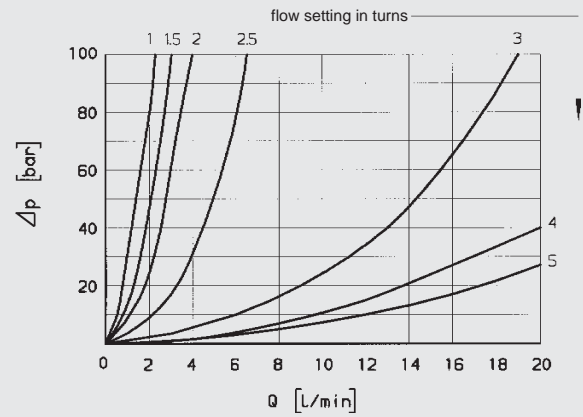

DVP/DRVP-08-01.X

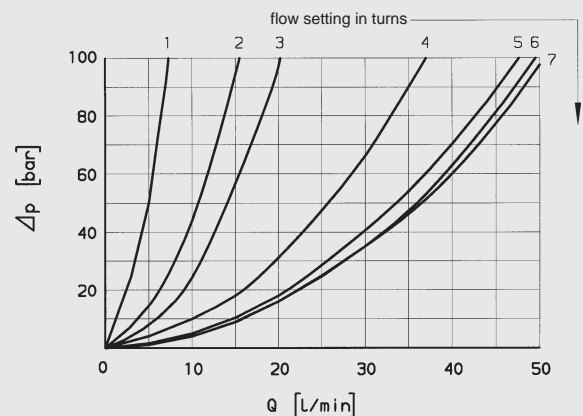

DVP/DRVP-10-01.X

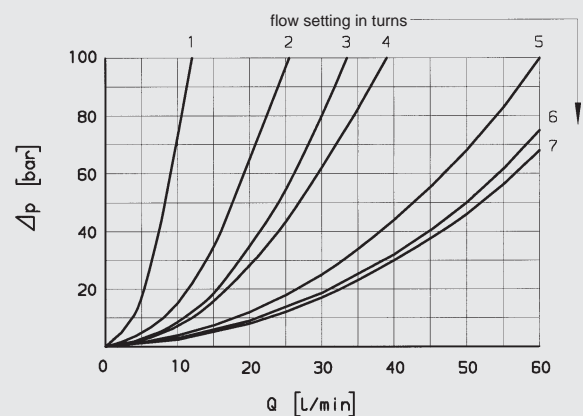

DVP/DRVP-12-01.X

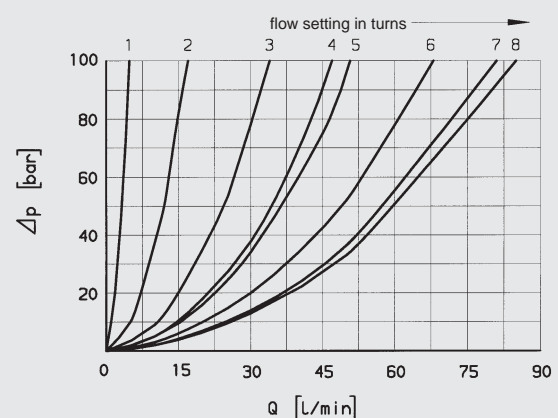

DVP/DRVP-16-01.X

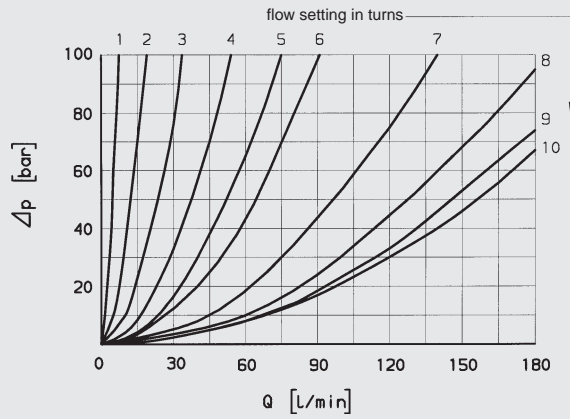

DVP/DRVP-20 to 40-01.X

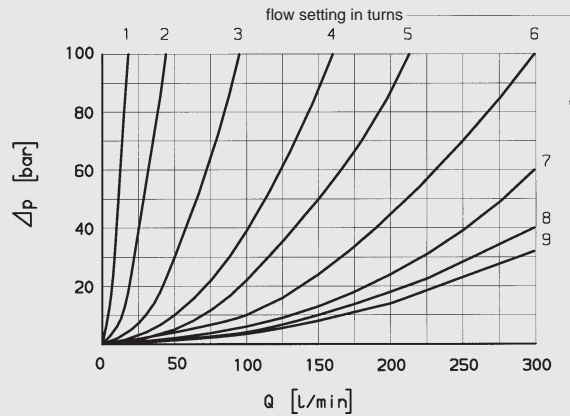

DRVP

Flow direction from B to A

Pressure differential Δp depending on flow rate Q via opened check valve at $v = 38 \text{ mm}^2/\text{s}$ and $t_{\text{oil}} = 43 \text{ }^\circ\text{C}$

DRVP-06 to DRVP-40-01.X

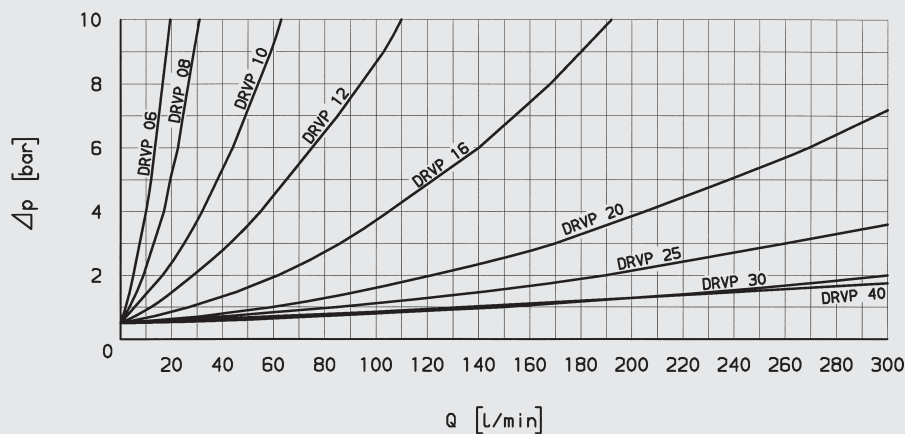

2.2.10 Accessories

Metal control knobs, zinc-plated
The metal control knobs with
HYDAC label are pre-assembled.

Size	Stock no.
06	550 063
08	550 023
10	550 023
12	550 066
16	550 066

When ordered, the accessories
are supplied loose with the
standard valve.

Please quote the stock number
when ordering.

2.1.11 Seal kits

555089	Seal kit NG06 DV/P DRV/P RVP
555090	Seal kit NG08 DV/P DRV/P DVE RVP SRV/P
555091	Seal kit NG10 DV/P DRV/P DVE RVP SRV/P
555092	Seal kit NG12 DV/P DRV/P DVE RVP SRV/P
555093	Seal kit NG16 DV/P DRV/P DVE RVP SRV/P
555094	Seal kit NG20 DV/P DRV/P RVP SRV/P
555095	Seal kit NG25 DV/P DRV/P RVP
555096	Seal kit NG30 DV/P DRV/P RVP
561456	Seal kit NG40 DV/P DRV/P RVP

3. DIMENSIONS

DVP

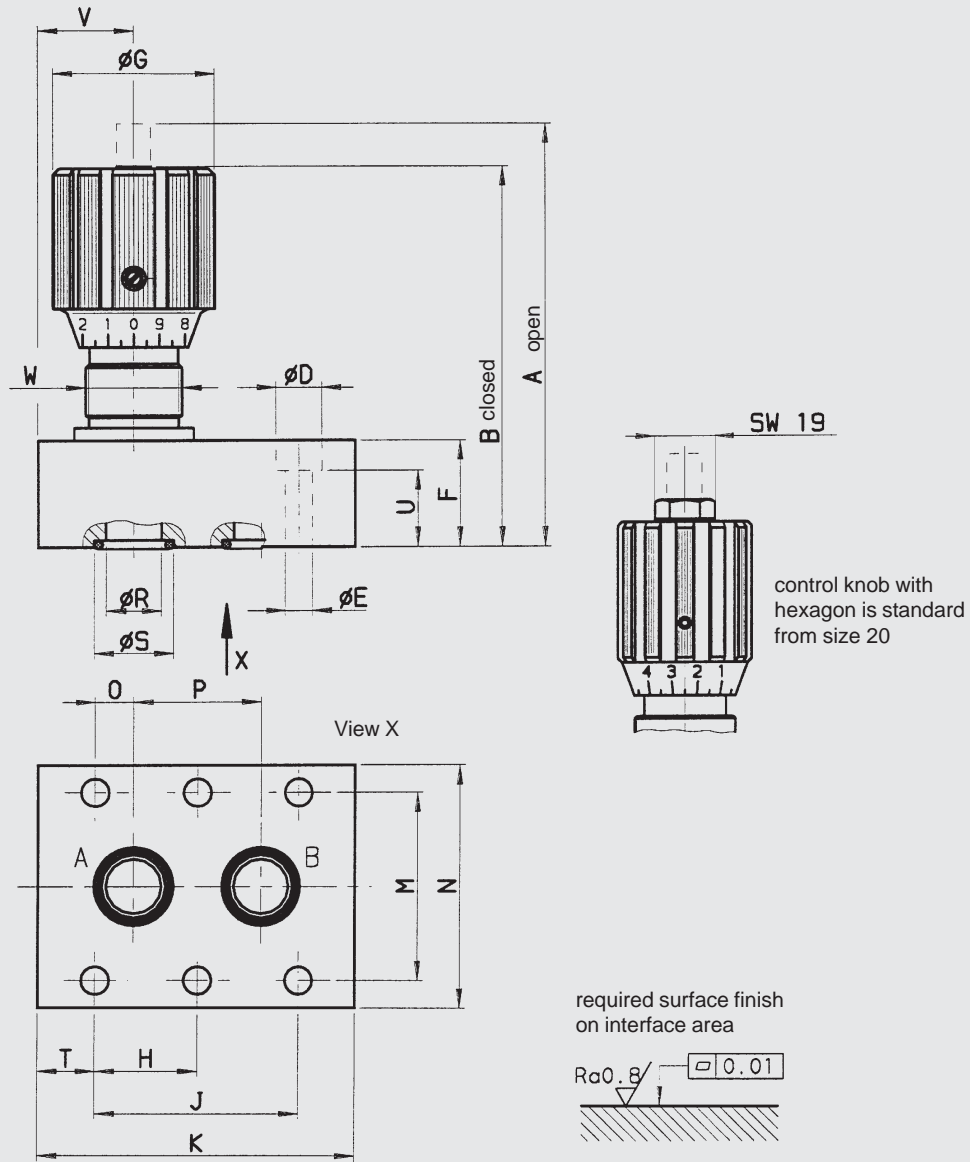

Size	A	B	D	E	F	G	H	J	K	M
06	63	58	11	6.6	16	24	–	19.0	35.0	28.5
08	79	72	11	6.6	20	29	–	35.0	47.5	33.5
10	84	77	11	6.6	25	29	–	33.5	51.0	38.0
12	99	89	11	6.6	25	38	–	38.0	75.0	44.5
16	113	103	14	9.0	30	38	38.0	76.0	93.5	54.0
20	165	148	14	9.0	45	49	47.5	95.0	111.0	60.0
25	165	148	18	11.5	45	49	60.0	120.5	143.0	76.0
30	170	153	20	14.0	50	49	71.5	143.0	171.0	92.0
40	170	153	20	14.0	50	49	67.0	133.5	192.0	111.0

Size	N	O	P	R	S	T	U	V	W	Weight [kg]
06	41.5	1.5	16.0	5.0	9.7	8.0	9	9.5	PG 7	0.20
08	46.0	4.5	25.5	7.0	12.7	6.5	13	12.0	PG 11	0.40
10	51.0	4.2	25.5	10.0	15.6	8.5	18	14.0	PG 11	0.60
12	57.5	4.0	30.0	13.0	18.6	18.5	18	22.5	PG 16	1.00
16	70.0	11.0	54.0	17.0	24.5	8.5	21	19.5	PG 16	1.70
20	76.5	19.1	57.0	22.0	30.5	8.0	36	31.5	PG 29	3.60
25	100.0	20.8	79.5	28.5	37.4	11.0	34	46.0	PG 29	5.50
30	115.0	23.8	95.0	35.0	43.4	15.0	37	39.0	PG 29	7.50
40	140.0	25.5	89.0	47.5	57.5	16.0	37	58.0	PG 29	8.20

DRV

Type :

01

12

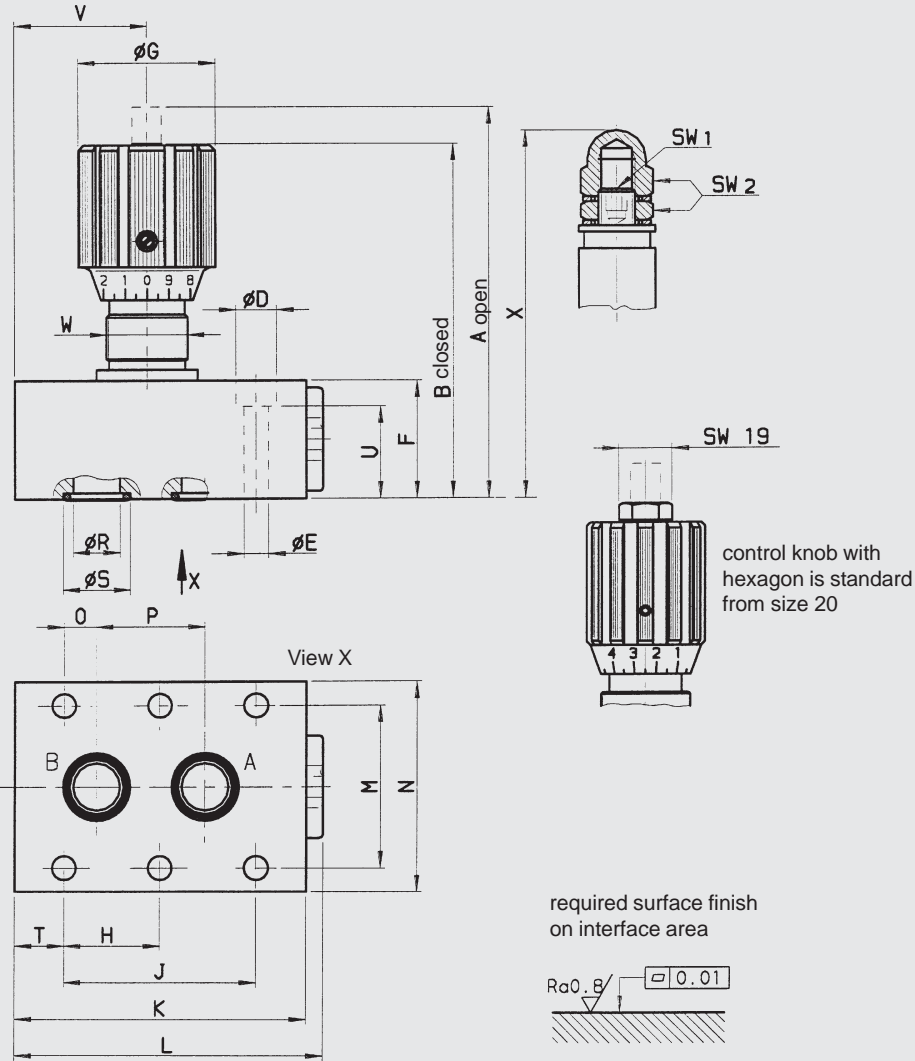

control knob with hexagon is standard from size 20

required surface finish on interface area

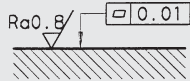

Size	A	B	D	E	F	G	H	J	K	L	M	N
06	63	58	11	6.6	16	24	–	19.0	41.5	46.0	28.5	41.5
08	79	72	11	6.6	20	29	–	35.0	63.5	67.0	33.5	46.0
10	84	77	11	6.6	25	29	–	33.5	70.0	74.0	38.0	51.0
12	106	96	11	6.6	32	38	–	38.0	80.0	84.5	44.5	57.5
16	128	118	14	9.0	45	38	38.0	76.0	104.0	109.5	54.0	70.0
20	170	153	14	9.0	50	49	47.5	95.0	127.0	133.0	60.0	76.5
25	175	158	18	11.5	55	49	60.0	120.5	165.0	172.0	76.0	100.0
30	195	178	20	14.0	75	49	71.5	143.0	186.0	196.0	92.0	115.0
40	220	203	20	14.0	100	49	67.0	133.5	192.0	201.0	111.0	140.0

Size	O	P	R	S	T	U	V	W	SW1	SW2	X	Weight [kg]
06	1.6	16.0	5.0	9.7	6.4	9	13.5	PG 7	–	–	–	0.26
08	4.8	25.5	7.0	12.7	14.2	13	31.0	PG 11	–	–	–	0.50
10	4.0	25.5	10.0	15.6	18.0	18	29.5	PG 11	6	13	81	0.80
12	4.0	30.0	13.0	18.6	21.0	25	36.5	PG 16	6	17	100	1.10
16	11.0	54.0	17.0	24.5	14.0	36	49.0	PG 16	8	19	127	2.50
20	19.0	57.0	22.0	30.5	16.0	41	49.0	PG 29	–	–	–	3.90
25	20.6	79.5	28.5	37.4	15.0	44	77.0	PG 29	–	–	–	6.70
30	23.8	95.0	35.0	43.4	15.0	62	85.0	PG 29	–	–	–	11.00
40	25.5	89.0	47.5	57.5	16.0	87	64.0	PG 29	–	–	–	17.50

4. NOTE

The information in this brochure relates to the operating conditions and applications described. For applications or operating conditions not described, please contact the relevant technical department. Subject to technical modifications.