

Proportional Pressure Relief Valve PDB06

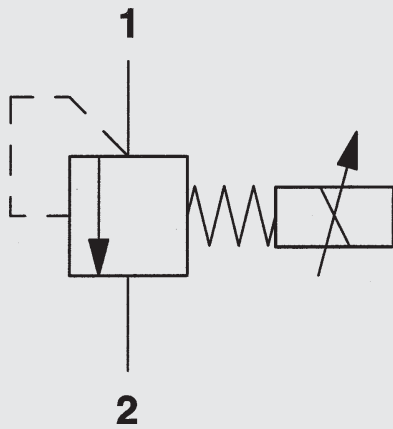

up to 350 bar
up to 5 l/min

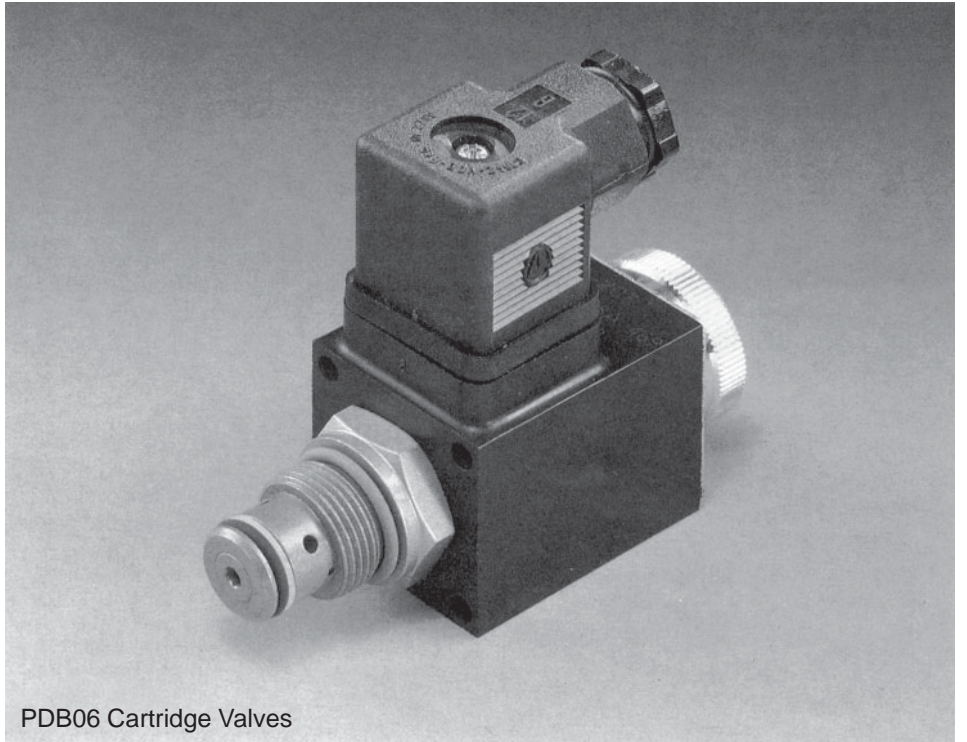

PDB06 Cartridge Valves

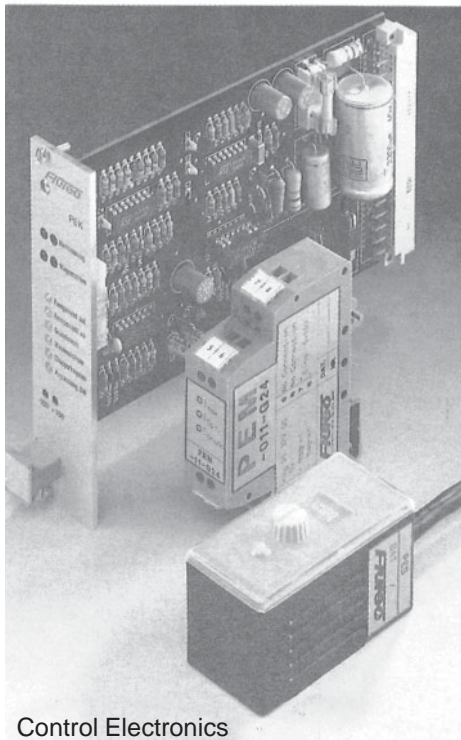

Control Electronics

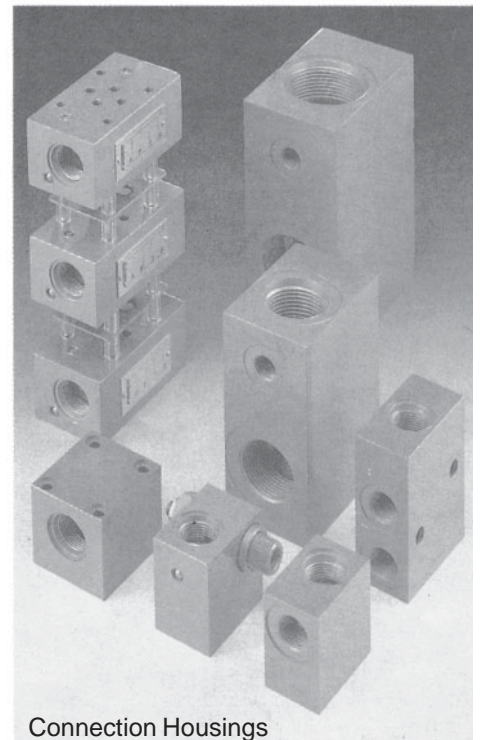

Connection Housings

1. DESCRIPTION

1.1. GENERAL

HYDAC proportional pressure relief valves, type PDB, are "control valves for oil hydraulic systems, where the inlet pressure is controlled by opening the outlet port to the tank against a counter force (solenoid spring system)" as specified by DIN-ISO 1219. The pressure is controlled electrically, the signal being supplied by appropriate control electronics which operate the solenoid. This solenoid is of the core tube type and has the following advantages:

- completely sealed
- low noise level and long service life due to oil damping
- good heat dissipation via the oil
- solenoid coil can be turned through 360°, and removed without having to open the hydraulic system.

The control electronics for the valve are available in three versions and are pre-set in accordance with the relevant valve details. The valve design also allows the use of other commercially available control systems, however, in this case the valve characteristics can be different to those shown in this brochure.

The HYDAC proportional pressure relief valve PDB is designed as a compact cartridge valve and has the following advantages:

- standardised installation space
- space-saving installation in housings, control blocks etc.
- simple fitting and exchangeability
- interchangeable with mechanical pressure relief valves, type DB4
- excellent control and stability properties
- low hysteresis
- optimum system adjustment by means of 3 pressure ranges

A wide range of connection housings is available for a variety of applications

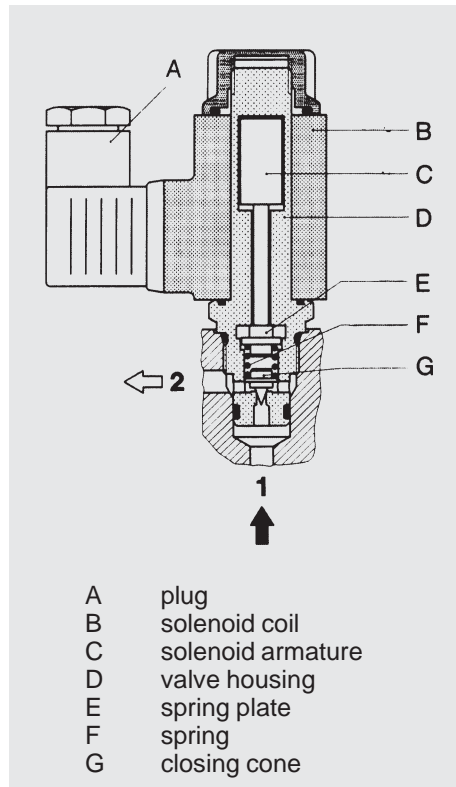

1.2. FUNCTION

HYDAC PDB proportional pressure relief valves are direct operated cone seat valves for oil hydraulic systems.

The valves consist basically of a heat-treated valve seat, the diameter of which varies according to the pressure range of the valve, a hardened and polished closing cone and a solenoid system for electrical operation.

The solenoid system of the valve carries out a stroke against the spring, depending on the amount of control current, thereby producing a certain spring pre-stress force. The spring applies this force to the closing cone and pushes it against the valve seat. On the opposite side of the closing cone the system pressure acts via port 1 of the pressure valve. If the hydraulic pressure force is below the pre-set spring force, the valve is closed.

If the hydraulic pressure force exceeds the pre-set spring force, the closing cone lifts off from the seat and connects pressure port 1 with tank port 2. This limits the system pressure to the value set by the solenoid system and the spring.

If the control current to the solenoid coil is interrupted, the spring relaxes and the system pressure drops to the minimum adjustable pressure ($p=f(Q)$ at 0 current).

1.3. APPLICATIONS

- In oil hydraulic systems for
- remote adjustment of pressure
 - automatic or manual adjustment of system pressure to required values
 - control of pressure performance
 - specific modulation of pressure increase and decrease
 - pilot operation of hydraulic valves and logic elements
 - control of adjustment devices on pumps and in pump control circuits

1.4. RECOMMENDATIONS

- to safeguard the maximum permissible system pressure, it is recommended that a separate pressure relief valve (e.g. DB4) is installed
 - minimum adjustment pressure to be taken into account (see point 2.2.9)
 - connections to be taken into account (see point 2.1.7)
 - torque figures to be taken into account (see point 3)
- In order to guarantee faultless operation and a long service life the following advice is recommended:
- vent valve during commissioning: Flush in preferred mounting position (solenoid pointing downwards) and repeat operation several times
 - avoid continuous operation of valve at maximum control current; in that case the next highest pressure range should be used
 - the cartridge valve is pre-set by the manufacturer and must neither be opened nor adjusted.

2. TECHNICAL SPECIFICATIONS

2.1. GENERAL

2.1.1 Designation and symbol Proportional pressure relief valve

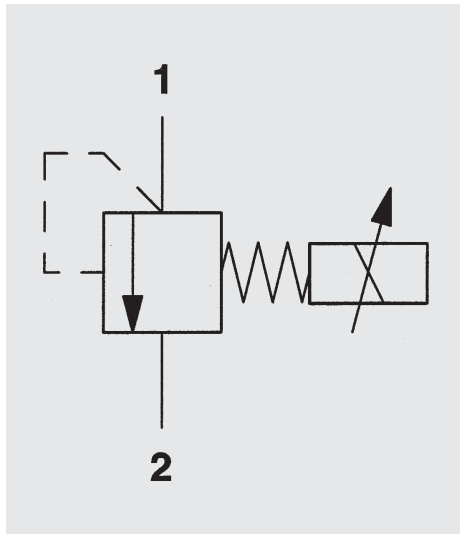

2.1.2 Model code (also order example)

PDB 06020 - 01 X - 070 - G24 - Z4

Proportional pressure relief valve

Installation dimensions

Type

01 = standard

Series

(determined by manufacturer)

Pressure range

070 = up to 70 bar

210 = up to 210 bar

350 = up to 350 bar

Nominal voltage

G24 = 24 V DC

Type of connection, electrical

Z4 = plug to DIN 43650-AF2-PG11

Standard models

Stock no.	Model code
716 200	PDB 06020-01X-070-G24-Z4
716 201	PDB 06020-01X-210-G24-Z4
716 202	PDB 06020-01X-350-G24-Z4

When ordering, please state stock no.

For non standard types delivery is longer and the price is higher.

2.1.3 Type of construction

Cone seat valve, direct operated

2.1.4 Type of mounting

Cartridge valve

2.1.5 Mounting position

optional,
solenoid pointing
downwards preferred
(see point 1.4.)

2.1.6 Weight

0.45 kg

2.1.7 Flow direction

According to symbol,
only permissible
in direction of arrow
Port 1:
pressure line (inlet)
Port 2:
tank line (outlet)

2.1.8 Ambient temperature range

Min. - 20 °C

Max. + 40 °C

2.1.9 Materials

Closing cone: hardened steel
Valve seat: high tensile steel
Valve body: free-cutting steel
Seals: FPM and PTFE

2.1.10 Type of connection

Various suitable connection
 housings with installation
 dimensions 06020 are available.
 See separate housing brochure
 no. E 5.252../..

2.1.11 Nominal size

NG = 06

2.2. HYDRAULIC DETAILS

2.2.1 Nominal pressure

Inlet (port 1) ... up to 350 bar depending on pressure range of valve

Outlet (port 2)
no pressure to tank

2.2.2 Operating pressure ranges

... up to 70 bar
... up to 210 bar
... up to 350 bar
for min. adjustment pressure see p_{\min} -Q-Graphs (point 2.2.9)

2.2.3 Operating fluid

Hydraulic oil to DIN 51524, Part 1 and 2

2.2.4 Operating fluid temperature range

Min. - 20 °C
Max. + 70 °C

2.2.5 Viscosity range

Min. 10 mm²/s
Max. 380 mm²/s

2.2.6 Flow rate

depending on pressure range
pressure range 070:
... up to 5 l/min
pressure range 210:
... up to 5 l/min
pressure range 350:
... up to 3 l/min

2.2.7 Filtration

Max. permissible contamination rate of the operating fluid to ISO 4406 Class 20/18/15 (NAS 1638, class 9). We recommend a filter with a minimum retention rate of $\beta_{10} \geq 100$.

The fitting of filters and regular replacement of filter elements guarantees correct operation, reduces wear and tear and increases the service life.

2.2.8 Performance graphs

(measured at $v = 65 \text{ mm}^2/\text{s}$
and $t = 30 \text{ °C}$)

Pressure range 070 bar (G24)

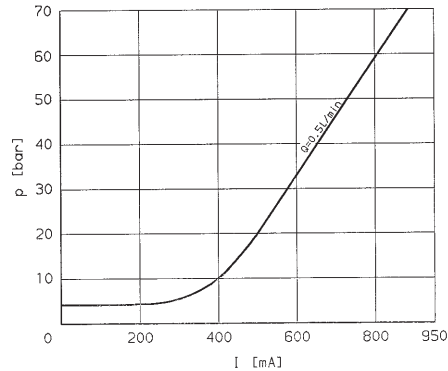
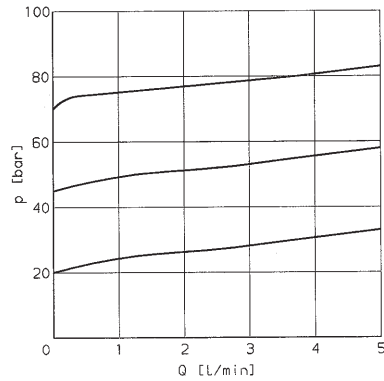

Pressure range 350 bar (G24)

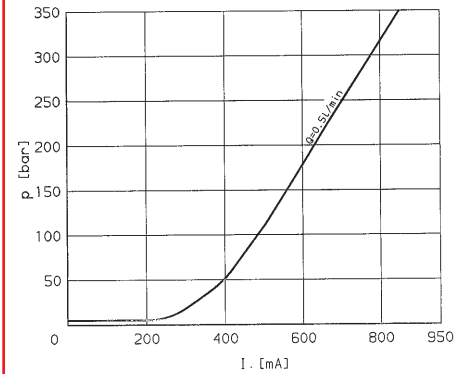
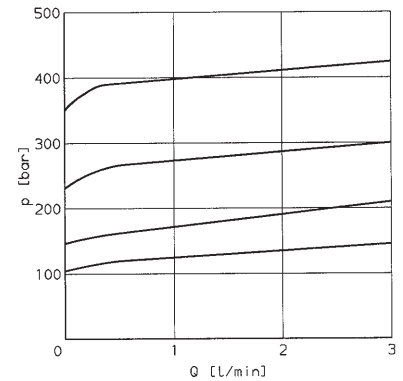

Pressure range 210 bar (G24)

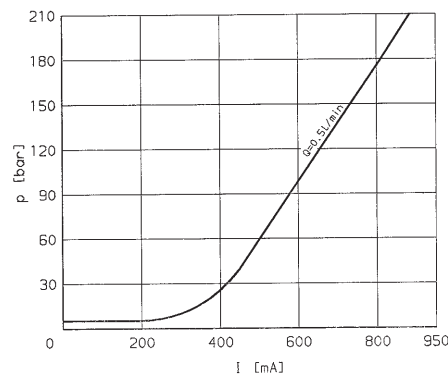
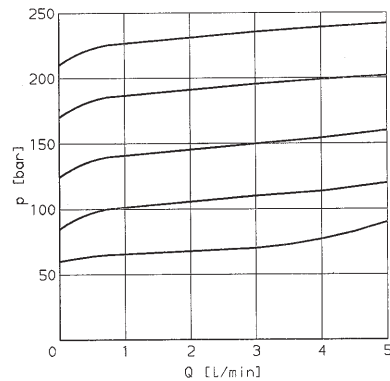

- 2.2.9 **Minimum adjustment pressure**
A pressure adjustment to a value below the line is not possible.

Pressure range 070 bar

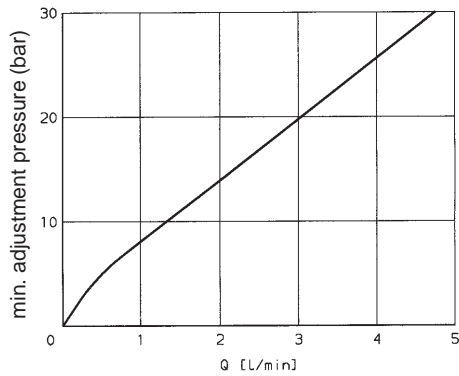

Pressure range 210 bar

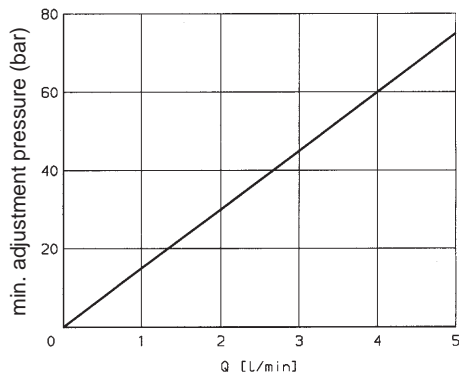

Pressure range 350 bar

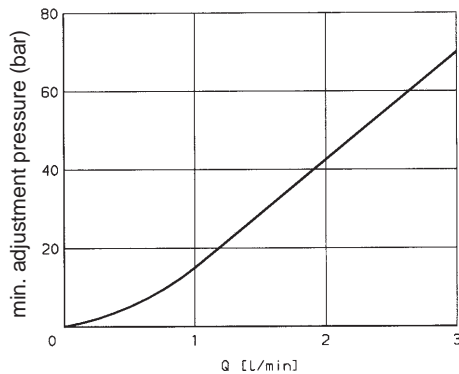

- 2.2.10 **Hysteresis**
≤ 4.5 %

2.3. TYPE OF OPERATION

2.3.1 **Construction**

Electro-magnetic by means of a pressure resistant core tube single stroke proportional solenoid

- 2.3.2 **Voltage**
DC

- 2.3.3 **Controlling current range**
G24: 0 ... 950 mA

- 2.3.4 **Coil resistance**
G24: $R_{20} = 15.3 \text{ Ohm}$

- 2.3.5 **Switching time**
100 %

- 2.3.6 **Safety type**
IP65 to DIN 40050
for correctly fitted connector

3. DIMENSIONS

PDB 06020

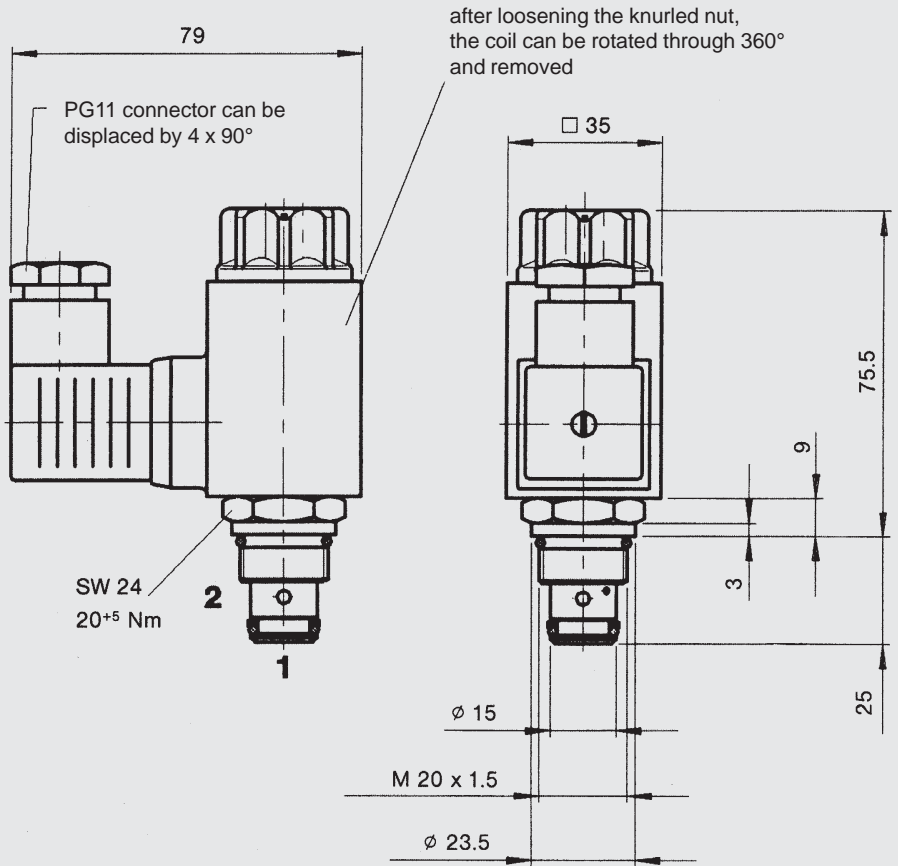

Installation dimensions 06020

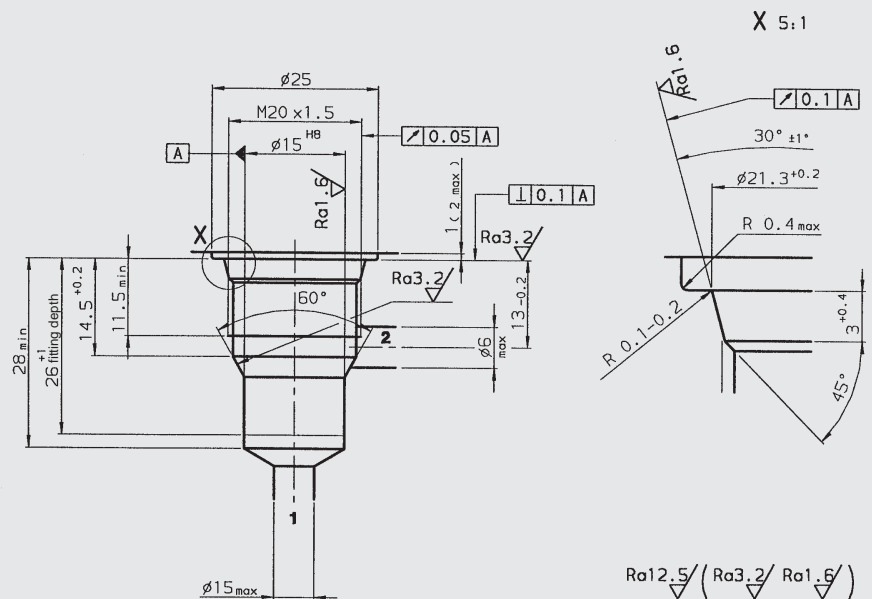

Cartridge form tools

Tool	Stock No.
Countersink	170033
Reamer	1000768
Tap	1002648
Plug gauge	168840

4. CONTROL ELECTRONICS

4.1 ELECTRONIC AMPLIFIER TYPE OF CONSTRUCTION

PEK

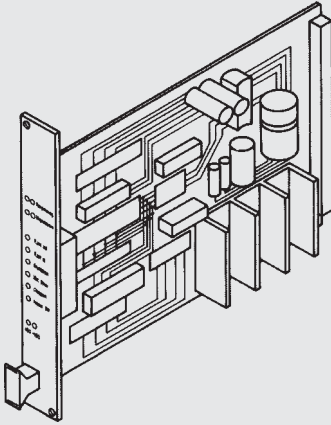

PEK: 19" Euro card system

- plug connector: male multipoint DIN 41612-D032
- Euro card system 100 x 160 mm
- 6 TE front plate width (1 TE = 5.08 mm)
- low-loss PDM output stage
- differential input (0-10 V) with level adjustment
- additional input for direct potentiometer connection
- 2 independently adjustable ramp times
- LED display for supply voltage
- base and maximum current adjustable
- chopper frequency adjustable

PES

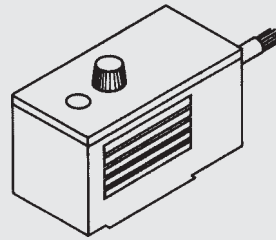

PES: Plug amplifier for fitting directly onto valve solenoids

- suitable for fitting onto solenoid for valve type ...PDB06020
- compact component, can be separated from the solenoid system
- low-loss PDM output stage
- differential input (0 - 10 V)
- reverse polarity protected and short-circuit proof
- LED display for control start
- base, step and maximum current adjustable

PEM

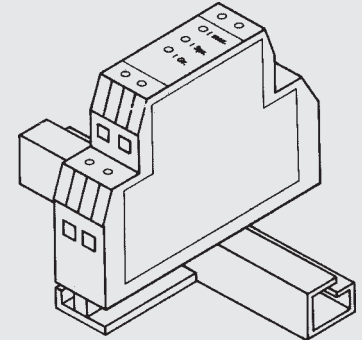

PEM: Amplifier module

- can be mounted onto DIN EN 50022 rail and DIN EN 50035 rail
- compact construction
- replaces terminal strip
- low-loss PDM output stage
- differential input (0 - 10 V)
- reverse polarity protected and short-circuit proof
- base, step and maximum current adjustable

4.2 MODEL CODE
(also order example)

PES - 01 X - G24

Proportional electronic amplifier construction

PEK = 19" Euro card system

PES = plug amplifier

PEM = amplifier module

Type

00 = not pre-set

01 = pre-set to suit PDB06020

Series

(determined by manufacturer)

Supply voltage

G24 = 24 V DC

Standard models:

Stock no. (= order no.)	Model code
479 001	PEK-01X-G24
716 225	PES-01X-G24
479 101	PEM-01X-G24

Please quote stock no. when ordering.

Delivery for non-standard models is longer and the price is higher.

4.3 SUPPLY VOLTAGE

PEK: 24 V DC \pm 10 % (permissible residual ripple 49 %)

PES: 20-32 V DC (permissible residual ripple 5 %)

PEM: 20-32 V DC (permissible residual ripple 5 %)

4.4 CURRENT OUTPUT

Amplifier type	Base current (mA)	Step current (mA)	Maximum current (A)	Chopper frequ. (Hz)	Ramp times up/down (sec)
PEK-00X-G24	0-500	–	0-1.6	50-200	0.1-10/0.1-10
PEK-01X-G24	200	–	0.95	160	0.1-10/0.1-10
PES-00X-G24	0-700	0-600	0-1.6	160	–
PES-01X-G24	200	0	0.95	160	–
PEM-00X-G24	0-700	0-600	0-1.6	160	–
PEM-01X-G24	200	0	0.95	160	–

4.5 REFERENCE INPUT

PEK: 0-10 V DC and direct potentiometer connection

PES: 0-10 V DC

PEM: 0-10 V DC

5. NOTE

The information in this brochure relates to the operating conditions and applications described.

For applications or operating conditions not described, please contact the relevant technical department.

Subject to technical modifications.

4.6 DIMENSIONS
PEK

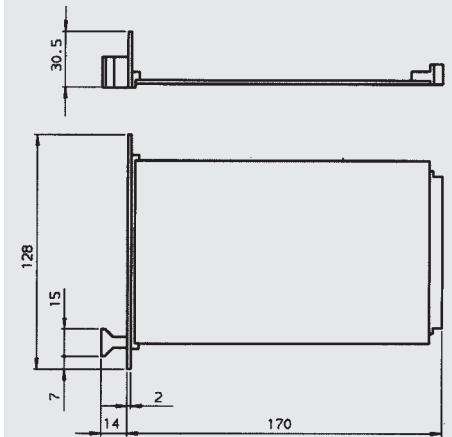

PES

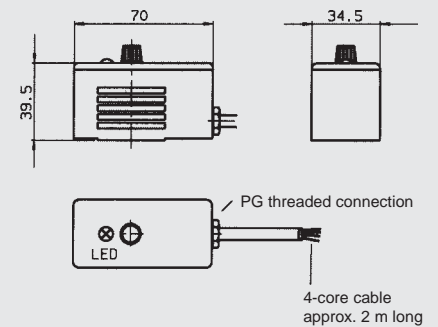

PEM

