

Directional Seat Valve WSE 3

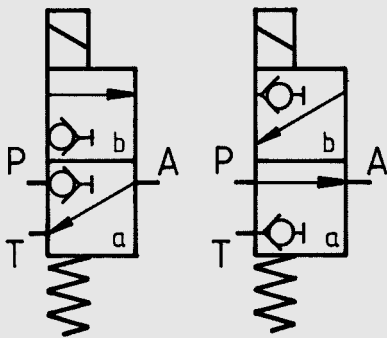

Up to 500 bar
Up to 12 l/min



Type WSE 3 E cartridge valve

1. DESCRIPTION

1.1. GENERAL

According to DIN-ISO 1219 HYDAC WSE 3 directional seat valves are directional valves which open and close one or more flow paths. The opening and closing functions are performed by solenoid operated control elements. These valves are all size 3.

1.2. MODE OF OPERATION

HYDAC WSE 3 directional seat valves are ball seat type valves. The control elements are hardened and polished.

This means:

- In the closed position the flow paths are leakage-free and pressure tight. This enables reliable positioning of cylinders and maintenance of pressure over long periods.
 - The valves have a high level of switching safety even after long periods of non-actuation at high pressure.
- The actuating solenoids of these direct-operated valves are of the wet-pin type. This type of construction has the following advantages:
- Fully enclosed design
 - Low noise level and long life due to oil-dampened armature impact
 - Good heat dissipation via the oil
 - Solenoid coils can be rotated through 360° and are removable
 - Solenoid coils can be changed and coils of different voltages can be fitted without interruption to the hydraulic system.

The solenoids are principally designed for DC operation. For operation with AC supply, the required DC supply is produced by means of bridge rectifier connectors (type W).

All seals coming into contact with the operating fluid are in Viton or PTFE as standard.

1.3. TYPE OF CONNECTION

HYDAC WSE 3 E directional seat valves are cartridge type valves for mounting onto manifold blocks, housings, cylinders etc. Housings for inline mounting and manifold mounting are available (see brochure Connection Housings for Cartridge Valves no. E 5.252../.).

2. TECHNICAL SPECIFICATIONS

2.1. GENERAL

2.1.1. Designation and symbol 3/2 directional seat valves Symbol C

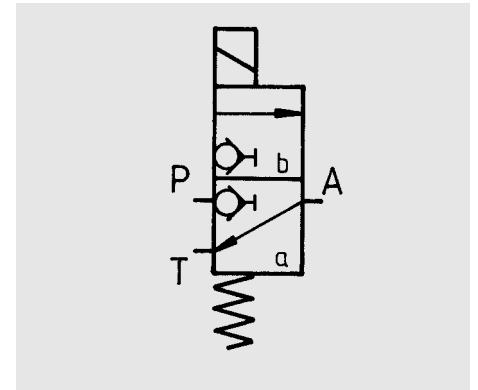

3/2 directional seat valve, P is closed and leakage free, A to T is open (switching position a). When the solenoid is actuated, P to A is opened and port T is closed and leakage free (switching position b). Flow is only permissible in direction of arrow.

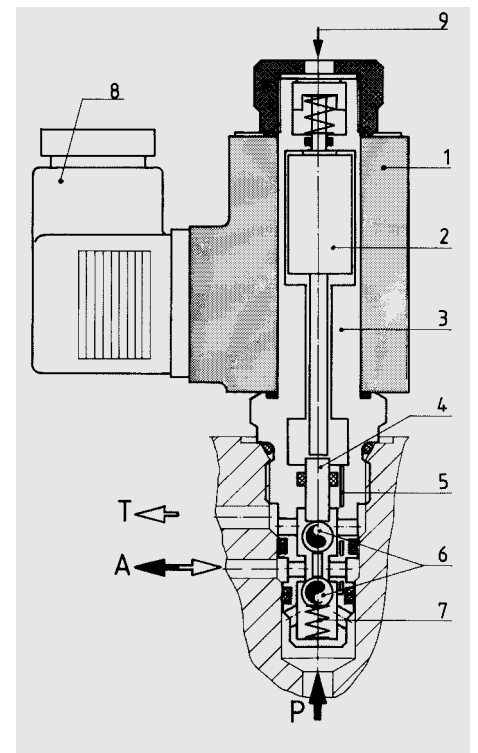

- Item 1 solenoid coil
- Item 2 solenoid armature
- Item 3 solenoid valve housing
- Item 4 pressure compensating piston
- Item 5 pressure compensating bore
- Item 6 closing element
- Item 7 spring
- Item 8 plug
- Item 9 emergency manual override

Symbol D

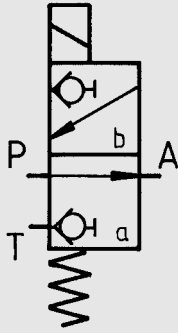

3/2 directional seat valve; P to A normally open, T closed and leakage free (switching position a). When the solenoid is actuated, port P is closed and leakage free and A to T is open (switching position b). Flow is only permissible in direction of arrow.

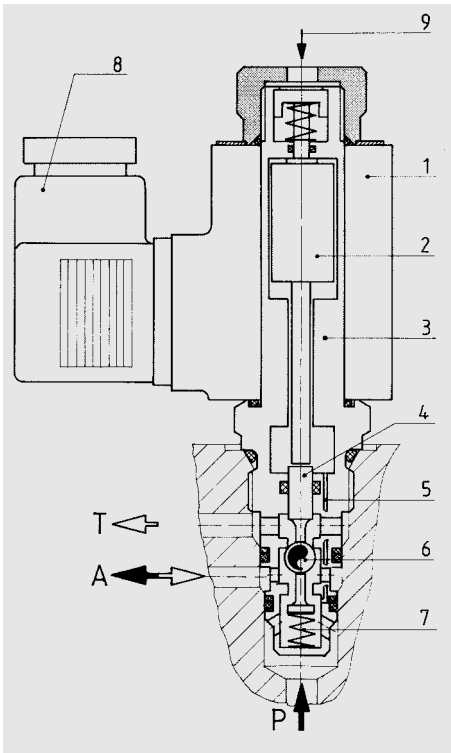

- Item 1 solenoid coil
- Item 2 solenoid armature
- Item 3 solenoid valve housing
- Item 4 pressure compensating piston
- Item 5 pressure compensating bore
- Item 6 closing element
- Item 7 spring
- Item 8 plug
- Item 9 emergency manual override

2.1.2. Model code for directional seat valves

(also ordering example)

WSE3E0C.X/G24-Z5L-N

Directional seat valve _____

Type of operation _____

E = solenoid operated

Size _____

Type of connection _____

E = cartridge

Additional functions _____

0 = technical specifications as per this brochure

Symbol _____

(see point 2.1.1.)

C = 3/2 directional seat valve, P to A normally closed

D = 3/2 directional seat valve, P to A normally open

Series _____

(determined by manufacturer)

Type of voltage for solenoid (see point 2.3.4.) _____

G = DC

W = AC, rectifier plug required

AC models are not dependent on frequency

Nominal voltage for solenoid _____

(see point 2.3.3.)

24 = 24 V DC (standard)

230 = 230 V 50/60 Hz AC (standard)

Electrical connection for actuating solenoid

no details = DIN 43650 plug without connector

Z4 = connector DIN 43650-AF2-Pg11

Z5 = large connector

Z5L = large connector with light

for AC type,
connector is automatically supplied with bridge rectifier insert

Emergency manual operation _____

(see point 4)

no details = no emergency manual operation

N = pin type operation

NG = thumb pressure operation

Standard models

Model Code	Symbol	Stock no. (= order code)
WSE 3 E 0 C.X / G24-Z4-N		710 462
WSE 3 E 0 C.X / W230-Z4-N		710 463
WSE 3 E 0 D.X / G24-Z4-N		710 464
WSE 3 E 0 D.X / W230-Z4-N		710 465

- 2.1.3. **Type of construction**
Ball seat valve, direct operated
- 2.1.4. **Type of connection**
Cartridge valve
- 2.1.5. **Weight**
WSE 3 E = 0.43 kg
- 2.1.6. **Mounting position**
Optional, but preferably the solenoid should be fitted pointing upwards to horizontal
- 2.1.7. **Flow direction**
According to symbol, permissible only in direction of arrow
- 2.1.8. **Materials**
Valve seats, closing elements and actuating elements: hardened steel
- 2.1.9. **Ambient temperature range**
Min. - 20 °C
Max. + 40 °C

2.2. HYDRAULIC DETAILS

- 2.2.1. **Operating pressure**
Nominal pressure $P_N=500$ bar across all ports
Pressure across $P \geq A \geq T$
- 2.2.2. **Pressure fluid**
Hydraulic fluid to DIN 51524 Parts 1 and 2. For other media, please consult our Sales/Technical Department
- 2.2.3. **Temperature range of fluid**
Min. - 20 °C
Max. + 80 °C
- 2.2.4. **Viscosity range**
Min. 10 mm²/s
Max. 380 mm²/s
- 2.2.5. **Flow rate**
 $Q_{max} = 12$ l/min
dependent on pressure

Performance graph

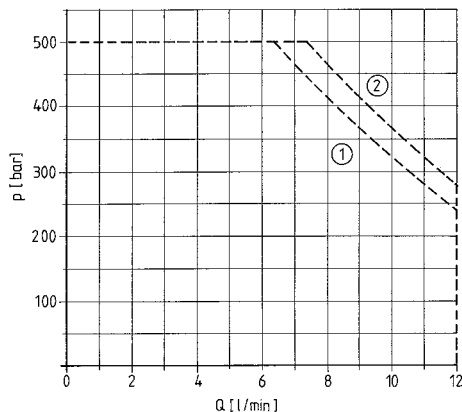

Symbol	Curve
C	1
D	2

The maximum permissible flow rate must not be exceeded.
If necessary, an orifice must be fitted to protect the valve.

- 2.2.6. **Filtration**
Max. permissible contamination level of operating fluid
 - at operating pressure up to 350 bar
NAS 1638, class 10.
We recommend a retention rate of $\beta_{20} \geq 100$.
 - at operating pressure up to 500 bar
NAS 1638, class 9.
We recommend a filter with a minimum retention rate of $\beta_{10} \geq 100$.

The installation filters and regular replacement of elements guarantees correct performance, reduces wear and tear and increases the service life.

- 2.2.7. **Switching overlap**
Negative; during switching all ports are momentarily interconnected.

- 2.2.8. **Δp -Q Curves**
Measured at $v = 34$ mm²/s
WSE 3 E

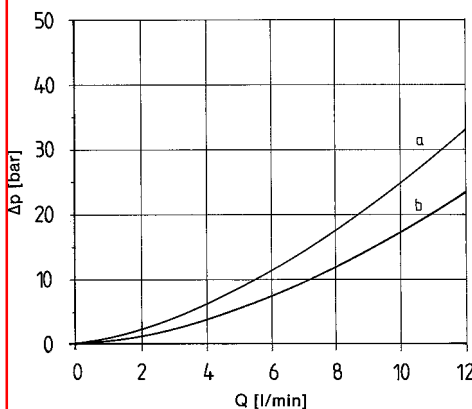

Symbol	Flow direction	Curve
C	P → A	a
	A → T	a
D	P → A	b
	A → T	b

2.3. ELECTRICAL DETAILS

- 2.3.1. **Type of operation**
Solenoid operated by means of pressure-tight, wet-pin single stroke solenoids to VDE 0580.
- 2.3.2. **Switching time**
(at nominal voltage)
Depending on pressure across individual ports and flow rate, switch-on time is approximately 40 ms, switch-off time approximately 45 ms.
- 2.3.3. **Nominal voltage U_N**
Voltages available:
Voltage type G: **24 V**
Voltage type W: **230 V**
Other voltages in the range 6 to 240 V are available on request.
- 2.3.4. **Type of voltage**
DC solenoid (code G).
For use with AC, the required DC is produced by using a bridge rectifier connector (code W).
- 2.3.5. **Voltage tolerance**
+ 10 %
- 5 %
- 2.3.6. **Power consumption**
 $P_{20} = 26$ W
- 2.3.7. **Switch-on time**
100% switch-on time = continuous operation. Minimum dimensions for housing of WSE 3 E cartridge valve: 50 x 50 x 30 mm.
- 2.3.8. **Safety type**
IP 65 to DIN 40050 provided connector is fitted correctly.
- 2.3.9. **Switching frequency**
3600 per hour maximum

3. DIMENSIONS

WSE 3

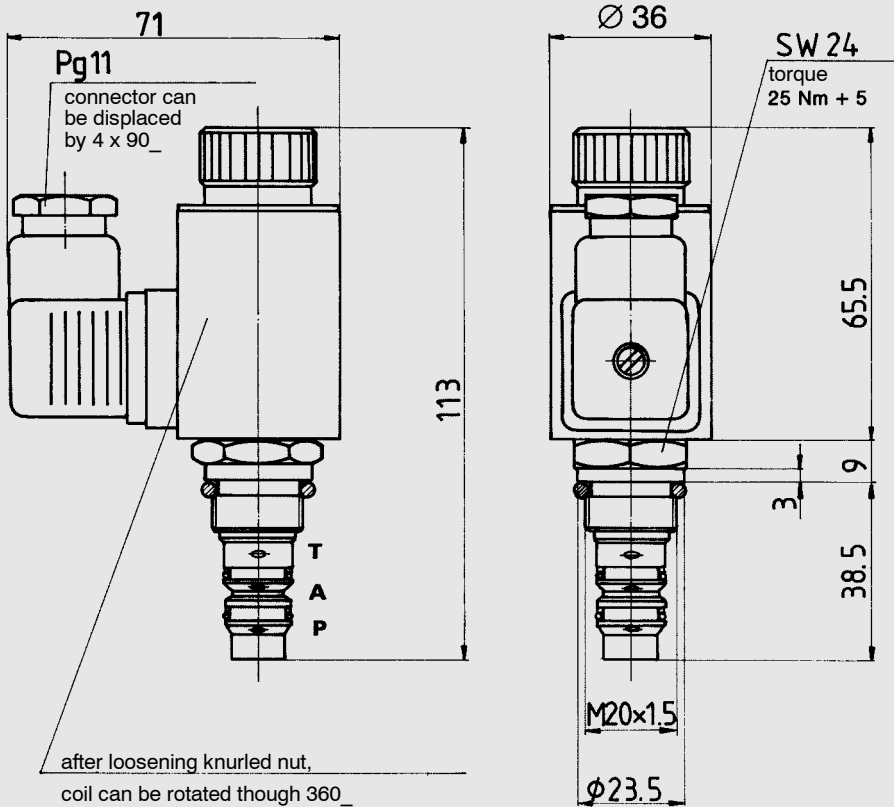

after loosening knurled nut,
coil can be rotated through 360°
and removed

4. EMERGENCY MANUAL OPERATION

no details

= no emergency manual operation

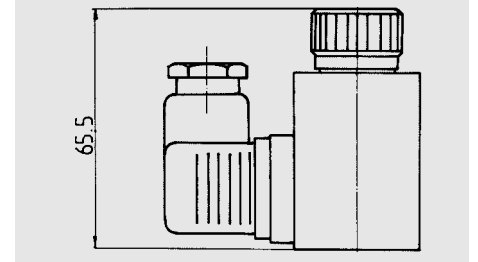

Mechanical operation is not possible

N = pin type operation

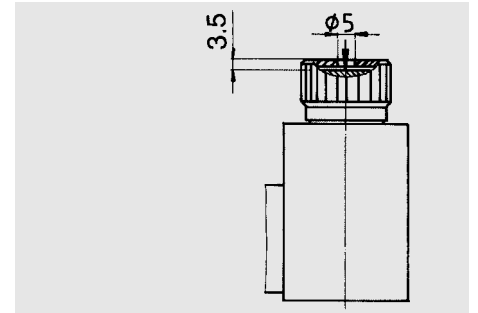

Mechanical override by means of pin. The opening is 5 mm in diameter. The pin is countersunk by 3.5 mm. The operating stroke is 1.5 mm.

NG = thumb pressure operation (rubber cap)

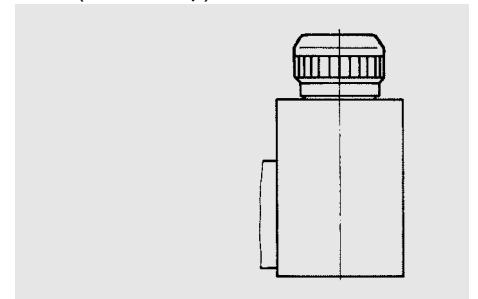

Mechanical operation without tool is possible (thumb pressure)

Installations dimensions for WSE 3

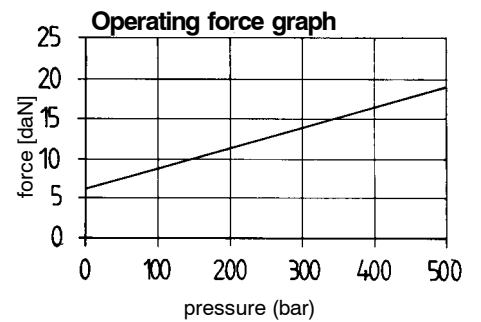
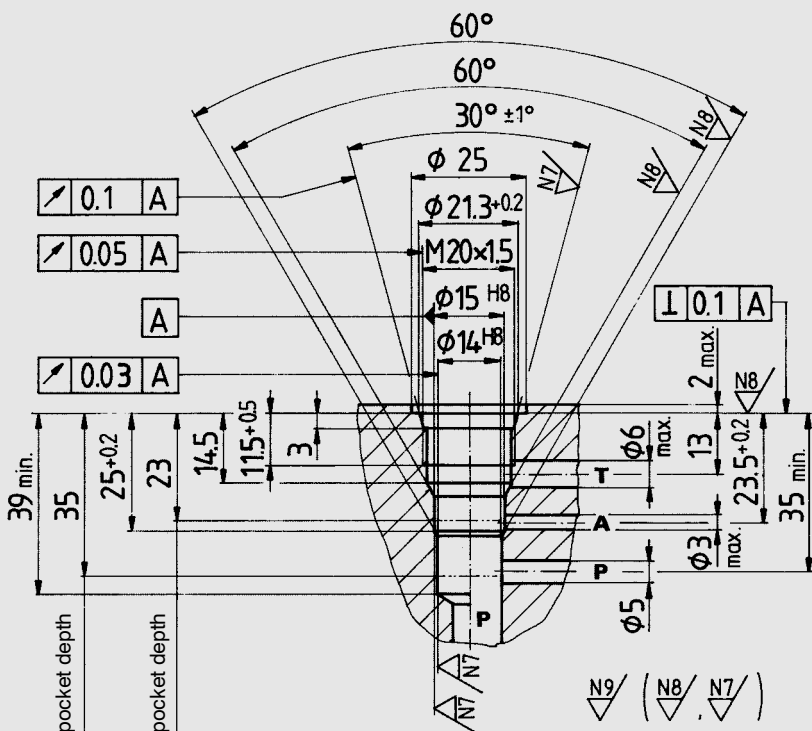

5. NOTE

The information in this brochure relates to the operating conditions and applications described. For applications or operating conditions not described, please contact the relevant technical department. Subject to technical modifications.