

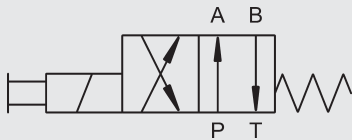

SYMBOL



up to 60 l/min
up to 315 bar

FUNCTION

HYDAC 4/2 directional spool valves in the series 4WE 6 D are directional valves for oil-hydraulic systems, which serve to open and close flow paths. In the de-energised mode the control spool is held in the rest position by the return spring. The actuation of the control spool occurs via an oil-immersed solenoid. The solenoid pushes the control spool from its rest position to its final position. This opens the required flow paths according to the symbol. When the solenoid is de-energised, the control spool is pushed back to the rest position by the return spring. A manual override permits the valve to be switched without energising the solenoid.

GENERAL

- Direct operated, solenoid-actuated directional valve NG 6
- Economical and reliable due to simple design
- Oil-immersed solenoid armature for long life and low noise operation
- Solenoid coils can be replaced with no possibility of oil leakage
- Interface to DIN 24340 Form A, ISO 4401 and CETOP-RP 121 H
- Manual override

SPECIFICATIONS

Operating pressure:	Port A, B, P Port T	$p_{\max} = 315 \text{ bar}$ $p_{\max} = 210 \text{ bar}$
Flow rate:	Max. 60 l/min	
Temperature range of operating fluid:	-20 °C up to + 80 °C	
Ambient temperature range:	-20 °C up to + 50 °C	
Operating fluid:	Hydraulic oil to DIN 51524 Part 1 and 2	
Viscosity range:	2.8 mm ² /s to 500 mm ² /s is recommended	
Filtration:	Max. permissible contamination level of the operating fluid to ISO 4406 Class 20/18/15	
Type of voltage:	DC voltage (12 V and 24 V available)	
Voltage tolerance:	±10%	
Nominal power rating:	26 W	
Switching time:	Switch-on time: 20 ms to 45 ms Switch-off time: 10 ms to 25 ms	
Duty cycle:	100% (continuous operation)	
Electrical connection:	Plug to DIN 43650	
Safety type:	IP 65 to DIN 40050 provided the connector is fitted correctly	
Max. switching frequency:	15000/h	
Manual override:	Possible up to approx. 50 bar tank pressure	
Mounting position:	Optional	
Sealing material:	FKM	
Weight:	1.2 kg	

DIMENSIONS

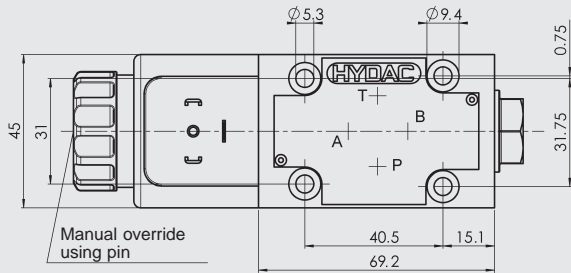
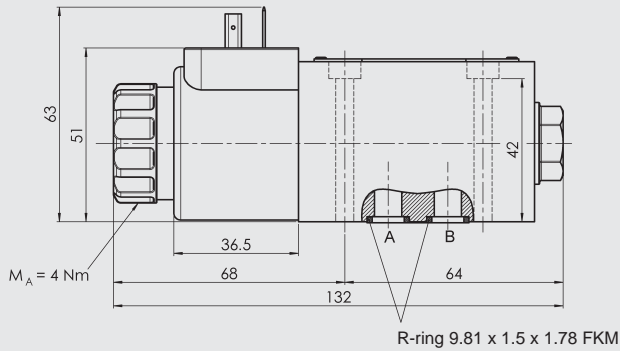

Interface to DIN 24340 Form A,
ISO 4401 and CETOP-RP 121 H

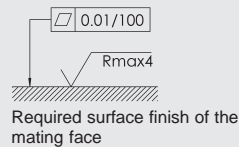

Valve mounting screws ISO 4762-M5x50-10.9,
 $M_A = 9 \text{ Nm}$, are not supplied.

INTERFACE

DIN 24340 Form 4, ISO 4401 and CETOP-RP 121 H

PRESSURE DROP

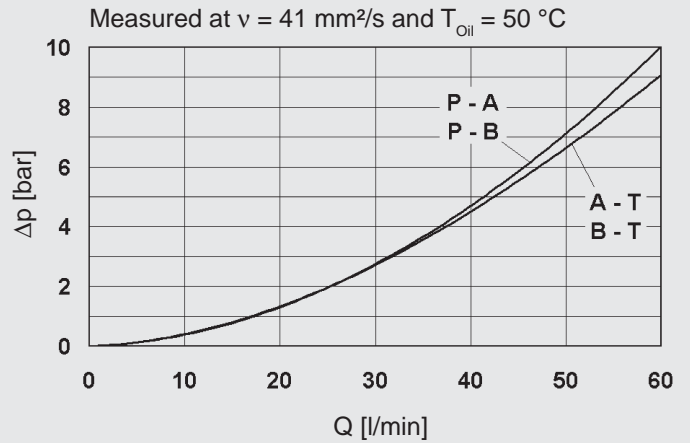

OPERATING LIMITS

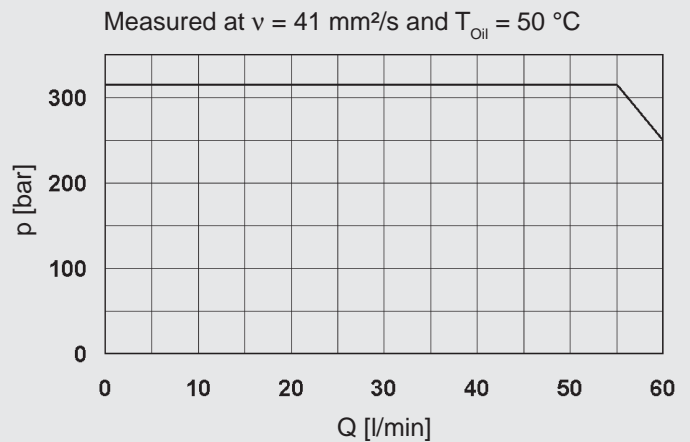

The operating limits were determined using solenoids at operating temperature, 10% under voltage and with no back-pressure in the tank line.

The operating limits given are for applications with two flow directions (e.g. from P to A and simultaneous return flow from B to T). For flow in only one direction (e.g. P to A and port B blocked), the operating limits can be considerably lower. Please consult HYDAC for applications of this kind.

MODELS

Voltage	Type	Stock no.
12 V	4WE 6 D12-6004973	6004973
24 V	4WE 6 D24-6004974	6004974

NOTE

The information in this brochure relates to the operating conditions and applications described.

For applications or operating conditions not described, please contact the relevant technical department.

Subject to technical modifications.

HYDAC Fluidtechnik GmbH

Justus-von-Liebig-Str.
D-66280 Sulzbach/Saar
Tel: 0 68 97 / 509-01
Fax: 0 68 97 / 509-598
E-Mail: flutec@hydac.com