

Up to 25 l/min  
Up to 350 bar

## FUNCTION

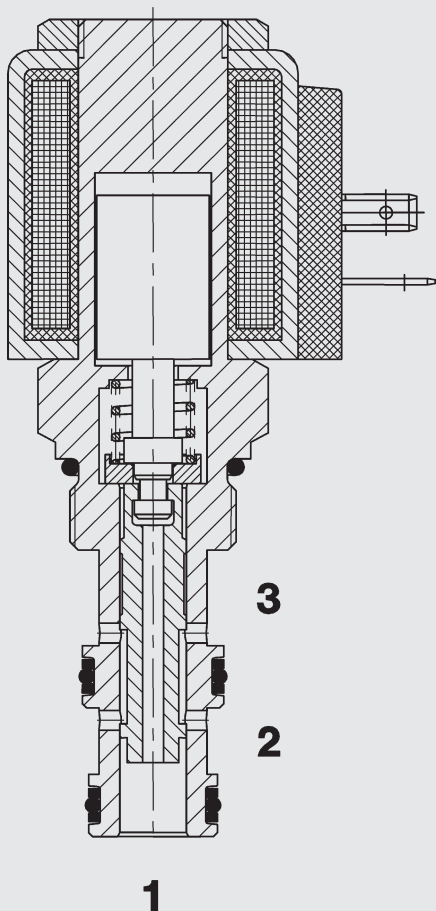

When the solenoid coil is not energized, there is free flow through the valve from port 3 to 2 or from 2 to 3, while port 1 is closed.

When the solenoid coil is energized, there is free flow through the valve from port 2 to 1 or from 1 to 2, while port 3 is closed.

## 3/2 Directional Spool Valve Solenoid Actuated, Direct Operated Cartridge Valve - 350 bar

WKM08130D-01

### GENERAL

- Oil-immersed armature for long life and low noise operation.
- Solenoid operation for all common international AC and DC voltages and available with many electrical connection types.
- Minimal wear and long life due to hardened and polished control spool.
- Solenoid coils can be rotated through 360° and replaced with no possibility of oil leakage.
- Surfaces are zinc-plated.
- Built-in seals protect solenoid coil from water penetration.
- Compact construction enables space-saving installation in connection housings and control blocks.

### SPECIFICATIONS

Operating pressure:	Max. 350 bar
Flow rate:	Max. 25 l/min
Internal leakage:	Max. 150 cm <sup>3</sup> /min at 250 bar
Temperature range of operating fluid:	-20 °C up to + 120 °C
Ambient temperature range:	-20 °C up to + 60 °C
Type of voltage:	DC solenoid, AC voltage is rectified using a bridge rectifier built into the coil
Nominal voltage at 20 °C:	1.5 A at 12 V DC 0.8 A at 24 V DC
Voltage tolerance:	-15% up to +15%
Duty cycle:	100% (continuous)
Switching time:	On: approx. 40 ms Off: approx. 30 ms
Operating fluid:	Hydraulic oil to DIN 51524 Part 1 and 2
Viscosity range:	10 mm <sup>2</sup> /s to 420 mm <sup>2</sup> /s is recommended
Filtration:	Max. permissible contamination level of the operating fluid to ISO 4406 Class 21/19/16
Mounting position:	Optional
Materials:	Valve body: high tensile steel Spool: hardened and polished steel Seals: NBR (standard) FKM (optional) Back-up rings in PTFE
Cavity:	08130
Weight:	Valve complete: 0.37 kg Coil only: 0.19 kg

