

FUNCTION

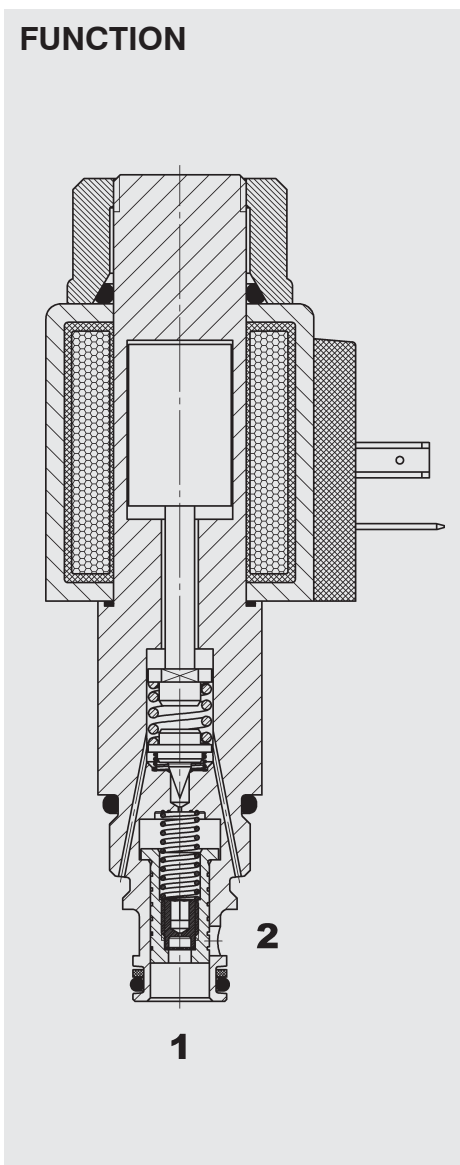

The PDB08P is a two stage spool type proportional pressure relief valve. If the pressure at port 1 rises above the setting defined by the electrical control signal, the pilot stage opens and allows flow from the back of the main piston to port 2. The resulting pressure imbalance causes the main piston to open against the return spring and allows flow from port 1 to port 2. As a function of the electrical signal the relief pressure at port 1 can be changed steplessly.

Proportional Pressure Relief Valve SAE 8-Cartridge – 350 bar

PDB08P-01

Spool Type – Pilot Operated

FEATURES

- All surfaces zinc-plated and corrosion proof
- All valve parts made of high-strength steel with hardened and ground components to ensure minimal wear and to extend service life
- Rigid design using one-piece body minimizes the effect of eccentricity and maximizes reliability
- Waterproof design standard
- Wide variety of connectors available
- Excellent stability throughout flow range
- Excellent dynamic performance
- Low pressure drop by CFD optimized flow-path
- Screen protected measuring orifice enhances safety

SPECIFICATIONS

Operating pressure:	max. 350 bar
Nominal flow:	max. 60 l/min
Operating pressure ranges:	up to 60 bar, up to 230 bar, up to 350 bar
Control current range:	1050 mA, 8.8 Ω / 2100 mA, 2.2 Ω
Internal leakage:	less than 0.5 l/min at 350 bar
Media operating temp. range:	-20 °C to +120 °C
Ambient temp. range:	-20 °C to +60 °C
Dither frequency:	180 Hz - 250 Hz
Response time:	On: approx. 50 ms, Off: approx. 30 ms
Hysteresis with dither:	2 - 4 % of maximum control current
Repeatability:	1.5 % of maximum pressure range
Reversal error:	≤ 2 % of maximum control current
Response sensitivity:	≤ 1 % of maximum control current
Fluids:	Mineral-based or synthetics with lubricating properties
Viscosity:	7.4 to 420 cSt
Filtration:	Class 18/16/13 up to 19/17/14 according to ISO 4406 or cleaner
Installation:	no orientation restrictions
Material:	Valve body: carbon steel Spool: carbon steel Seals: NBR (standard) FKM (optional) Coil: Steel / Polyamide

Notes:
The PDB08P can also be supplied with an emergency pressure adjustment (version -01M). This allows a mechanical pressure adjustment of the valve if the electrical signal is interrupted. This adjustment should be used only in the case of electrical failure since the manual setting would be additive to the electrical setting and the danger of equipment damage could develop.
In order to achieve optimal function, any trapped air should be vented with the bleed screw on the face of the tube (not fitted to version -01M).

Cavity:	FC08-2
Weights:	Valve complete: 430 g Coil only: 230 g

DIMENSIONS

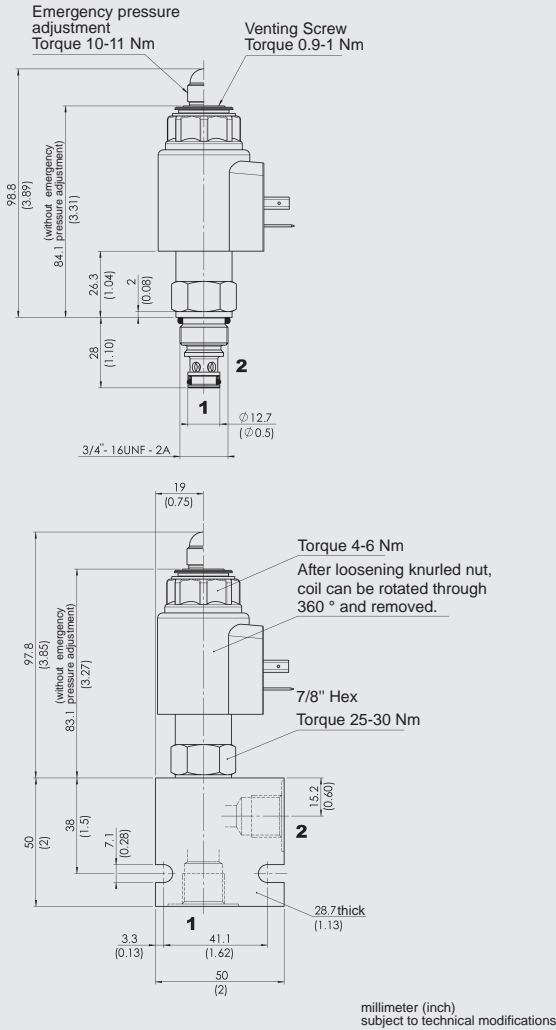

MODEL CODE

PDB08P-01 M - C - N - 330 - 24 PG - 8.8

Basic model

Option

Omission = No option

M = Emergency pressure adjustment

Body and Ports*

C = Cartridge only

SB3 = 3/8 BSP ports, steel body

SS6 = SAE-6 ports, steel body

AB3 = 3/8 BSP ports, aluminium body

AS6 = SAE-6 ports, aluminium body

Seals

N = NBR

V = FKM

Pressure range

87 = up to 60 bar

330 = up to 230 bar

500 = up to 350 bar

Coil voltage

12 = 12 V (2.2 Ω)

24 = 24 V (8.8 Ω)

Coil connector

PG = DIN connector (DIN 43650)

PL = Leadwires (2) – 457 mm (18") long

PN = Deutsch Connector DT04-2P-EP04 (axial)

PU = AMP Junior Timer, 2 pole, axial

Coil resistance

2.2 = 2.2 Ω (12 V)

8.8 = 8.8 Ω (24 V)

Standard models

Model code	Material no.
PDB08P-01-C-N-87-12PG-2.2	3144426
PDB08P-01-C-N-330-12PG-2.2	3144427
PDB08P-01-C-N-500-12PG-2.2	3144458
PDB08P-01-C-N-87-24PG-8.8	3144459
PDB08P-01-C-N-330-24PG-8.8	3144460
PDB08P-01-C-N-500-24PG-8.8	3144461

* Standard Line Bodies

Code	Part No	Material	Ports	Pressure
FH082-SB3	560919	Steel, zinc-plated	3/8 BSP	420 bar
FH082-SS6	560917	Steel, zinc-plated	SAE-6	420 bar
FH082-AB3	3011423	Aluminium, clear anodized	3/8 BSP	245 bar
FH082-AS6	3011409	Aluminium, clear anodized	SAE-6	245 bar

CAVITY

FC08-2

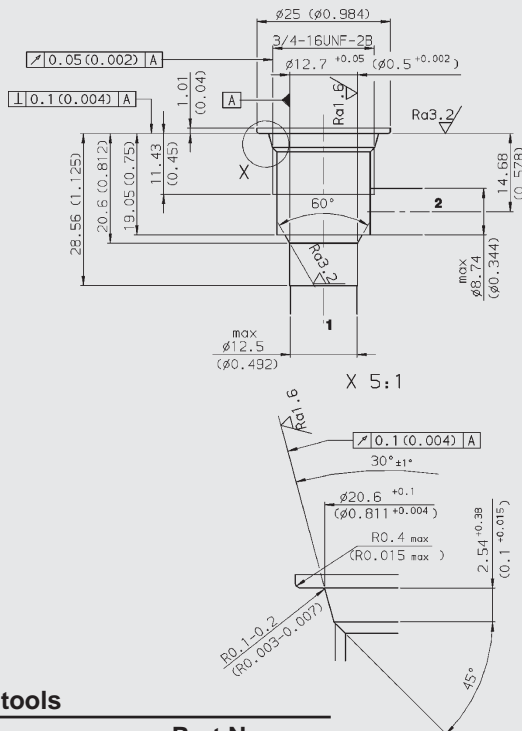

Form tools

Tool	Part No
Rougher FC08-2	175473
Finisher FC08-2	175474

millimeter (inch)
subject to technical modifications

PERFORMANCE

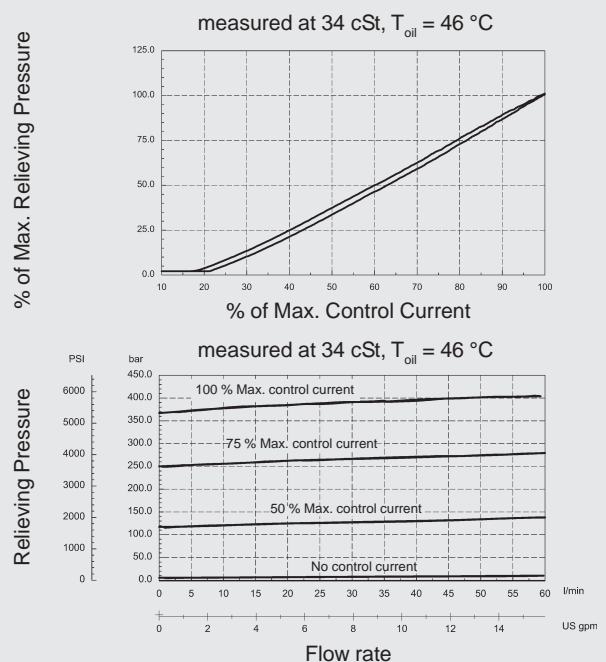

NOTE

The information in this brochure relates to the operating conditions and applications described. For applications or operating conditions not described, please contact the relevant technical department. Subject to technical modifications.

HYDAC Fluidtechnik GmbH

Justus-von-Liebig-Str.

D-66280 Sulzbach/Saar

Tel: 0 68 97 /509-01

Telefax: 0 68 97 /509-598

E-Mail: flutec@hydac.com